

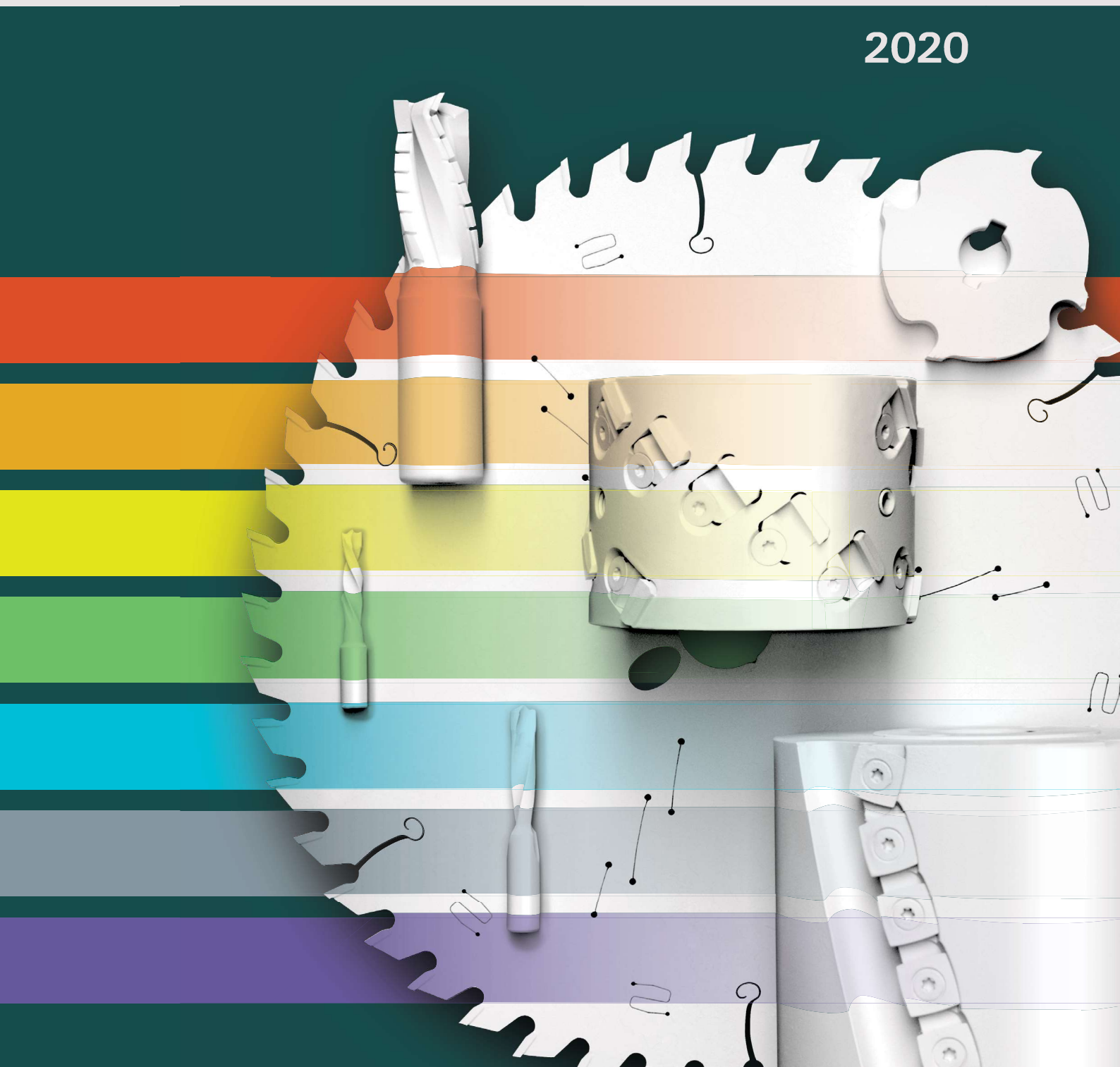

**Stehle**

**Gereedschapprogramma**

**2020**



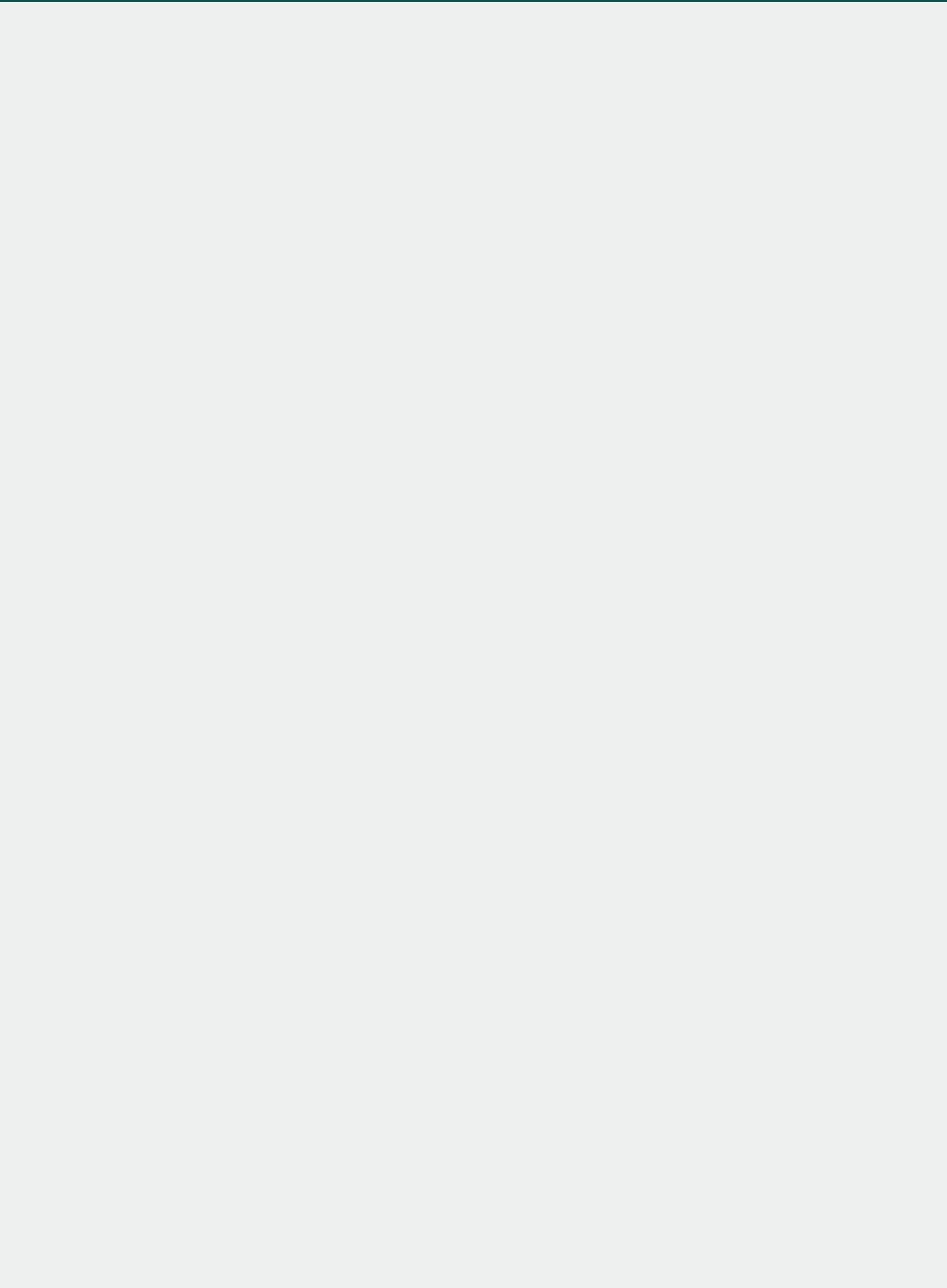



Gereedschapprogramma

**2020**

**Innovatief  
Indicatief  
Betrouwbaar**

|                         | MACHINE                                      | PROGRAMMA                                   | PAGINA          |      |
|-------------------------|--|---|-----------------|------|
| <b>CIRKELZAAGBLADEN</b> | Handcirkelzaagbladen                         | HKS - Massief - Accuhandcirkelzagen         | 1-1             |      |
|                         |  | HKS - Massief - Accuhandcirkelzagen WS      | 1-2             |      |
|                         |  | HKS - DP - Accuhandcirkelzagen              | 1-2             |      |
|                         |  | HKS - Mega-Steel - Accuhandcirkelzagen      | 1-3             |      |
|                         |  | HKS - Unisteel - Accuhandcirkelzagen        | 1-4             |      |
|                         |  | HKS - Massief                               | 1-5             |      |
|                         |  | HKS - Board                                 | 1-6             |      |
|                         |  | HKS - LR                                    | 1-7             |      |
|                         |  | HKS - L                                     | 1-8             |      |
|                         |  | HKS - L2                                    | 1-9             |      |
|                         |  | HKS - nn-System DP flex                     | 1-10            |      |
|                         |  | Unisteel (HKS)                              | 1-11            |      |
|                         |  | Parat - negatief (HKS)                      | 1-12            |      |
|                         |  | Handcirkelzaagbladen - Set HW               | 1-13            |      |
|                         |  | Tafelcirkelzaagbladen voor standaardmachine | K + G negatief  | 1-15 |
|                         |  |   | BKS (NAIL)      | 1-16 |
|                         |  |   | ZFL             | 1-17 |
|                         |  |   | ZWZ             | 1-18 |
|                         | ZW   |   | 1-19            |      |
|                         | ZOW  |   | 1-20            |      |
|                         | ZWS  |   | 1-21            |      |
|                         | ZWS-1  |   | 1-22            |      |
|                         | Matador 5                                    |   | 1-23            |      |
|                         | TRF  |   | 1-24            |      |
|                         | TRF - 1                                      |   | 1-25            |      |
|                         | Cirkelzaagbladen-set HW - een klus voor twee |   | 1-26            |      |
|                         | RSK - nn-System                              |   | 1-27            |      |
|                         | RSK  |   | 1-28            |      |
|                         | RS2  |   | 1-29            |      |
|                         | RSVS   |   | 1-30            |      |
|                         | RSVS   |   | 1-31            |      |
|                         | KDF - Industry - Negatief                    |   | 1-31            |      |
|                         | KDF - Industry                               |   | 1-32            |      |
|                         | KDF - Industry Plus                          |   | 1-32            |      |
|                         | KDF - Industry Professionell                 |   | 1-33            |      |
|                         | HRP - nn-System DP flex                      |   | 1-34            |      |
|                         | RSK - nn-System DP flex                      |   | 1-35            |      |
|                         | RSK - nn-systeem DP flex - verstelbaar       |   | 1-36            |      |
|                         | Platenopdeelzaagbladen                       |   | TFP             | 1-41 |
|                         |  |   | TFP             | 1-42 |
|                         |  |   | RSK - nn-System | 1-43 |
|                         |  |   | RSK             | 1-44 |
|                         |  | RSK-WS                                      | 1-45            |      |
|                         | Cirkelzaagbladen voor speciale toepassingen  | OKW   | 1-46            |      |
|                         |  | Planet                                      | 1-46            |      |
|                         |  | LWR   | 1-47            |      |
|                         |  | NE-positief                                 | 1-48            |      |
|                         |  | NE-negatief                                 | 1-49            |      |
|                         |  | NE - Positief - Profiel 'G7'                | 1-50            |      |
|                         |  | NE - Kap - Negatief - Profiel 'G7'          | 1-51            |      |
|                         |  | Unisteel                                    | 1-52            |      |

| MACHINE   | PROGRAMMA                                   | PAGINA  |   |
|---|---|---|---|
| <b>CIRKELZAAGBLADEN</b>                                     | Cirkelzaagbladen voor speciale toepassingen | Steel 1-53  |   |
|   |   | Mega-Steel 1-54                                       |   |
|   |   | KKS - Plastic 1-55                                    |   |
|   |   | KKS - Hard plastic positief 1-56                      |   |
|   |   | KKS - Hard plastic negatief 1-57                      |   |
|   |   | KKO 1-58  |   |
|   |   | KKM 1-59  |   |
|   |   | KKE 1-60  |   |
|   |   | Reduceerringen - gekarteld 1-61                       |   |
|   |   | Reduceerringen - vlak 1-62                            |   |
|   | <b>FREESGEREED-SCHAPPEN MET ASGAT</b>       | Groeffrezen   | 1103L Groeffrees - voor Lamello® 2-1                      |
| 3103L Groeffrees - voor Lamello® 2-1                        |   |   |   |
| 3140L Groeffrees voor Lamello Clamex P® 2-2                 |   |   |   |
| 1568 Keermessen groeffrees - Silverline - voor Lamello® 2-2 |   |   |   |
| 1103G Harsgalfrees 2-3                                      |   |   |   |
| 1101 Groefzaagblad 2-4                                      |   |   |   |
| NK 2-5  |   |   |   |
| NKP 2-5   |   |   |   |
| RNK-Matador 5 2-6   |   |   |   |
| RNK 2-7   |   |   |   |
| NK3VS 2-7   |   |   |   |
| 1503 Groeffrezen 2-8  |   |   |   |
| 5561 Keermesen-Groeffrezen - Silverline 2-9                 |   |   |   |
| 5562 Keermesen-Groeffrezen - Silverline 2-10                |   |   |   |
| Voegen/felsen/afschuiningen                                 |   |   | 1586 Groef- en sponningfrezen- Silverline 2-11            |
|   |   |   | 3584 Voegenfrees 2-12                                     |
|   |   |   | 3585Voegenfrees DP airFace 2-13                           |
|   |   |   | 3585-2 voegenfrees DP - HOLZ-HER - AirStream-systeem 2-14 |
|   |   |   | 3588-2 Strijkfrezen airFace 2-15                          |
|   |   | 1580 Zwenkfrezen 2-17                                 |   |
|   |   | Kantbewerking   | 3565 Kanten-afrondfrees 2-18                              |
| 3565-1 Kanten-afrondfrees 2-18                              |   |   |   |
| 3565-2 Kanten-afrondfrees CM 2-19                           |   |   |   |
| Profiel aanbrengen  |   | 5540 Bossingfrezen - Silverline 2-20                  |   |
|   |   | 1547 Universele Euro-Profiel frezen - Silverline 2-22 |   |
| Contra-profileren   |   | 5567 Contraprofiel frezen 2-23                        |   |
|   |   | 5554 Contraprofielgarnituur 2-24                      |   |
| Verlijmen   |   | 5556 Verstek-verlijmfrezen 2-25                       |   |
|   |   | 1534-2 Verlijmprofielfrezen 2-26                      |   |
| Schaafwerk  |   | 5570 Spiraal schaafkoppen 2-28                        |   |
|   |   | 556-1 Schaafkoppen 2-29                               |   |
|   |   | 520-1 Hydro-schaafkoppen 2-30                         |   |
|   |   | 569 Schaafmes HS - 18% 2-31                           |   |
|   |   | 569 Schaafmes HW belegd 2-32                          |   |
|   |   | 525 Rugvertande profielfrees 2-33                     |   |
|   |   | 521-1 Hydro-profielschaafkoppen 2-35                  |   |
|   |   | 525 Blankets met rugvertanding HS 2-37                |   |
|   |   | 464 HS stokkenfrezen 2-38                             |   |
|   |   | 464 HS segmenten voor gladde ronde stokken 2-39       |   |
|   |   | 464 HS segmenten voor geribde ronde stokken 2-40      |   |

|                                       | MACHINE                               | PROGRAMMA  | PAGINA             |      |
|---------------------------------------|---------------------------------------|--|--------------------|------|
| <b>FREESGEREED-SCHAPPEN MET ASGAT</b> | Schaafwerk                            | 4000 Groef- en veergereedschappen                    | 2-41               |      |
|                                       |                                       | 4010 Groef- en veergereedschap HW - Silverline       | 2-43               |      |
| <b>CNC-FREESGEREED-SCHAPPEN</b>       | HW-omkeermessen bovenfreesgereedschap | 2231 Schachtfrees                                    | 3-1                |      |
|                                       |                                       | 2233 Schachtfrees                                    | 3-2                |      |
|                                       |                                       | 2235 Schachtfrees                                    | 3-3                |      |
|                                       |                                       | 2236 Schachtfrees                                    | 3-4                |      |
|                                       |                                       | 2237 Schachtfrees                                    | 3-5                |      |
|                                       | VHW-schrob/afwerkfrezen               | 2265 Schrobfrees                                     | 3-6                |      |
|                                       |                                       | 2265-1 Schrobfrees                                   | 3-7                |      |
|                                       |                                       | 2257 Afwerkfrees                                     | 3-8                |      |
|                                       |                                       | 2257-1 Afwerkfrees                                   | 3-9                |      |
|                                       |                                       | 2257-2 Afwerkfrees                                   | 3-10               |      |
|                                       |                                       | 2268 Ventilatie schrobfrees                          | 3-11               |      |
|                                       | VHW-schrob/afwerkfrezen voor deuren   | 2269 Ventilatie afwerkfrees                          | 3-11               |      |
|                                       |                                       | 2254 Slotkasten-schrobfrees                          | 3-12               |      |
|                                       |                                       | 2254 Slotkasten-schrobfrees                          | 3-12               |      |
|                                       |                                       | 2255 Slotkasten-afwerkfrees                          | 3-12               |      |
|                                       | DP-bovenfrees recht                   | 3501 Schachtfrees                                    | 3-13               |      |
|                                       |                                       | 3502 Bovenfrees                                      | 3-14               |      |
|                                       |                                       | 3511 Highperformance Schrobfrees DP                  | 3-15               |      |
|                                       |                                       | 3510 Schrobfrees DP                                  | 3-15               |      |
|                                       |                                       | 3514 Schrob-afwerkfrees                              | 3-16               |      |
|                                       |                                       | 3503 High performance schachtfrees                   | 3-17               |      |
|                                       |                                       | 3509 Highperformance bovenfrees                      | 3-18               |      |
|                                       |                                       | 3505 High performance schachtfrees                   | 3-19               |      |
|                                       |                                       | 3513 High performance schachtfrees CM                | 3-20               |      |
|                                       |                                       | 3506 High performance schachtfrees CM                | 3-21               |      |
|                                       |                                       | 3507 High performance kantenfrees                    | 3-22               |      |
|                                       |                                       | 3600 p-systeem highperformance bovenfrees            | 3-23               |      |
|                                       |                                       | 3610 p-systeem highperformance-voeg-bovenfrees       | 3-24               |      |
|                                       |                                       | 3620 p-systeem highperformance-groeffrees            | 3-25               |      |
|                                       |                                       | Vlak-sponning bovenfrees                             | 1594 Vlakfrees     | 3-26 |
|                                       | 3508 Vlak- en sponningschachtfrees    |  | 3-26               |      |
|                                       | 5572 Vlakfrees- en sponningfrees      |  | 3-27               |      |
|                                       | Groef- en sponningfrezen              | 5575 Spiraal schaaftoppen                            | 3-28               |      |
|                                       |                                       | 5576 Groef- en sponningfrees                         | 3-29               |      |
|                                       | Voeg-fase bovenfrees                  | 1591 Siergroeffrees                                  | 3-30               |      |
|                                       |                                       | 1581 Zwenkfrees                                      | 3-31               |      |
|                                       |                                       | 5573 Folding-fasfrees                                | 3-32               |      |
|                                       |                                       | 1521 Zwaluwstaartfrees                               | 3-33               |      |
|                                       |                                       | 1522 Fasefrees                                       | 3-33               |      |
|                                       | Profiel-bovenfrees                    | 1520 Handgreepfrezen                                 | 3-34               |      |
|                                       |                                       | 1593 V-groeffrezen                                   | 3-34               |      |
|                                       |                                       | 1523 Afrond-fase-freeset Z=2                         | 3-35               |      |
|                                       |                                       | 1524 Leuningfrezen                                   | 3-36               |      |
|                                       |                                       | 3512 Profiel-groeffrees HW - voor Lamello Clamex P®  | 3-37               |      |
|                                       |                                       | 3519 Profiel-groeffrees VHW - voor Lamello Clamex P® | 3-37               |      |
|                                       |                                       | 3518 Profiel-groeffrees DP - voor Lamello Clamex P®  | 3-38               |      |
|                                       |                                       |  |                    |      |
|                                       | <b>BOOR</b>                           | Doorgangsboor  | 2010 Spiraalboor   | 4-1  |
|                                       |                                       |  | 2020 Doorgangsboor | 4-2  |
|                                       |                                       |  | 2021 Doorgangsboor | 4-3  |
|                                       |                                       |  | 2022 Doorgangsboor | 4-4  |
|                                       |                                       |  |                    |      |

|                                    | MACHINE                   | PROGRAMMA  | PAGINA                            |      |
|------------------------------------|---------------------------|--|-----------------------------------|------|
| <b>BOOR</b>                        | Drevelboor                | 2031 Drevelboren                                     | 4-5                               |      |
|                                    |                           | 2032 Drevelboren                                     | 4-6                               |      |
|                                    |                           | 2033 Drevelboren                                     | 4-7                               |      |
|                                    |                           | 2040 Drevelboren                                     | 4-8                               |      |
|                                    |                           | 2041 Drevelboren                                     | 4-9                               |      |
|                                    |                           | 2042 hoogwaardige drevelboor                         | 4-10                              |      |
|                                    | Cilinderkopboor           | 2050 Cilinderkopboor                                 | 4-11                              |      |
|                                    |                           | 2051 Cilinderkopboor                                 | 4-12                              |      |
|                                    | Verzinker                 | 2061 Opsteekverzinker                                | 4-13                              |      |
|                                    |                           | 2060 Verzinkboor                                     | 4-14                              |      |
|                                    |                           | 2062 Verzinker                                       | 4-15                              |      |
|                                    | <b>OPSPAN SYSTEMEN</b>    | Zaagopnamen  | Adapter met cilinderschacht       | 5-1  |
|                                    |                           |  | Adapter met cilinderschacht       | 5-2  |
|                                    |                           |  | CNC combizaagopname HSK 63F       | 5-3  |
|                                    |                           |  | Zagen-opname HSK 63F              | 5-4  |
| Booropnamen                        |                           | Adapter met cilinderschacht                          | 5-5                               |      |
|                                    |                           | Boor-adpater   | 5-6                               |      |
|                                    |                           | Boor-adpater - Combisysteem                          | 5-7                               |      |
|                                    |                           | CNC booropname                                       | 5-8                               |      |
| Spantangen                         |                           | Spantangopname met SK-schacht                        | 5-9                               |      |
|                                    |                           | Spantangenopname met SK-schacht met tandkrans        | 5-10                              |      |
|                                    |                           | Aantrekbout  | 5-11                              |      |
|                                    |                           | Spantangopname met HSK-63F                           | 5-12                              |      |
|                                    |                           | Precisiespantangen - 462E/OZ25                       | 5-13                              |      |
|                                    |                           | Precisiespantangen - 415E/OZ16                       | 5-14                              |      |
|                                    |                           | Precisiespantangen - 430E/ER25, 470E/ER32, 472E/ER40 | 5-15                              |      |
|                                    |                           | Hydro opnamen  | Hydro-opname ps-System met HSK63F | 5-16 |
| Reduceerhulzen                     |                           | Universele reduceerhulzen                            | 5-17                              |      |
| TRIBOS                             |                           | TRIBOS high-tech spantanghouder                      | 5-18                              |      |
| Krimpopnamen                       |                           | High-tech krimpopname                                | 5-19                              |      |
| <b>OPSPAN SYSTEMEN</b>             |                           | Toebehoren   | Opspandoorn met HSK-63F           | 5-20 |
|                                    |                           |  | Conusreiniger                     | 5-21 |
|                                    | Montage voorziening       |  | 5-21                              |      |
| <b>VERWISSELBARE PLATEN/MESSEN</b> | Voorsnijders/omkeermessen | Omkeermessen   | 6-1                               |      |
|                                    |                           | Omkeermessen   | 6-1                               |      |
|                                    |                           | Omkeermessen   | 6-2                               |      |
|                                    |                           | Omkeermessen   | 6-2                               |      |
|                                    |                           | Omkeermessen   | 6-3                               |      |
|                                    |                           | Omkeermessen   | 6-3                               |      |
|                                    |                           | Omkeermessen   | 6-4                               |      |
|                                    |                           | Omkeermessen   | 6-4                               |      |
|                                    |                           | Omkeermessen   | 6-5                               |      |
|                                    |                           | Omkeermessen   | 6-5                               |      |
|                                    |                           | Ruimer-omkeermessen                                  | 6-6                               |      |
|                                    |                           | Ruimer-omkeermessen                                  | 6-6                               |      |
|                                    |                           | Omkeermessen - Voorsnijders                          | 6-7                               |      |
|                                    |                           | Driehoek-voorsnijders                                | 6-8                               |      |
|                                    |                           | Groefmessen  | 6-8                               |      |
|                                    |                           | Mini-omkeermessen                                    | 6-9                               |      |
|                                    |                           | Handschaaf- omkeermessen                             | 6-10                              |      |



## STEHLE IS BETROUWBAAR

Al meer dan 90 jaar levert Stehle wereldwijd aan zowel gebruikers als de handel technisch perfecte machinegereedschappen. Stehle staat bekend om de zeer nauwkeurige en economische freeskoppen voor de be- en verwerking van massief hout.

Eind negentiger jaren werd het merk Stehle een onderdeel van de Ledermann-groep waarna Stehle zich consequent richtte op het leveren aan de vakhandel. Om aan deze eisen te kunnen voldoen werd het productassortiment uitgebreid met een breed scala aan cirkelzaagbladen en plaatbewerkingsgereedschappen.

STEHLE IS BETROUWBAAR ...



# BETROUWBAAR

Daniel Schrenk ist seit Januar 2014 Geschäftsführer Vertrieb und Marketing der Ledermann GmbH & Co. KG. Als gelernter Schreiner und Diplom-Holzingenieur kennt er die Anforderungen der Betriebe bestens.

## **” STEHLE – ein starker und zuverlässiger Partner für den Handel. Heute und in Zukunft.**

*... Der Fachhandel für Bearbeitungswerkzeuge steht im Spannungsfeld zwischen dem Risiko von den großen Direktanbietern der Branche Marktanteile abgenommen zu bekommen, andererseits bietet insbesondere das Thema Digitalisierung dem Handel heute zusätzliche Chancen und Marktanteile.*

*Digitalisierung als Chance für den Handel? Das mag auf den ersten Blick widersprüchlich klingen. So steht doch bei Online Portalen oft nur der Preis und nicht die Leistung, Funktion, Anwenderfreundlichkeit oder Beratungskompetenz im Vordergrund.*

*Bei genauerer Betrachtung zeigen sich vielseitige Möglichkeiten.*

*Sei es die Farbleitfunktion im elektronischen Katalog, Einsatz- und Anwendungsdaten über QR Codes am Werkzeug, kontinuierliche Servicezeiten über Online-Portale und vieles mehr.*

*Die Marke Stehle, begreift Digitalisierung als Chance und wir wollen diesen Weg gemeinsam mit Ihnen gehen.*

*Sie können sich auf Stehle verlassen als starken und zuverlässigen Partner, beheimatet in einer leistungsfähigen und innovativen Gruppenstruktur.*

*Viel Freude und Erfolg mit unserem neuen Katalog!  
Ob in Papierform, auf Ihrem PC oder Smartphone!* ”



Daniel Schrenk,  
Geschäftsführer

# Materialen die gebruikt worden bij het handmatig bewerken van hout, de interieurbouw en vergelijkbare werkzaamheden

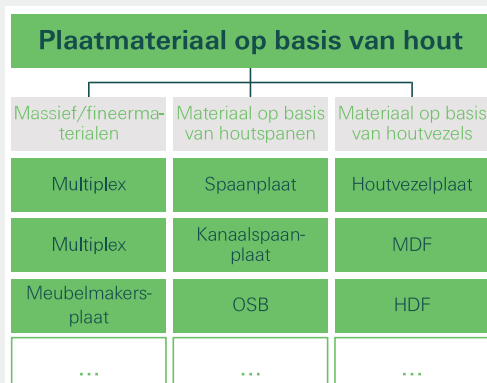
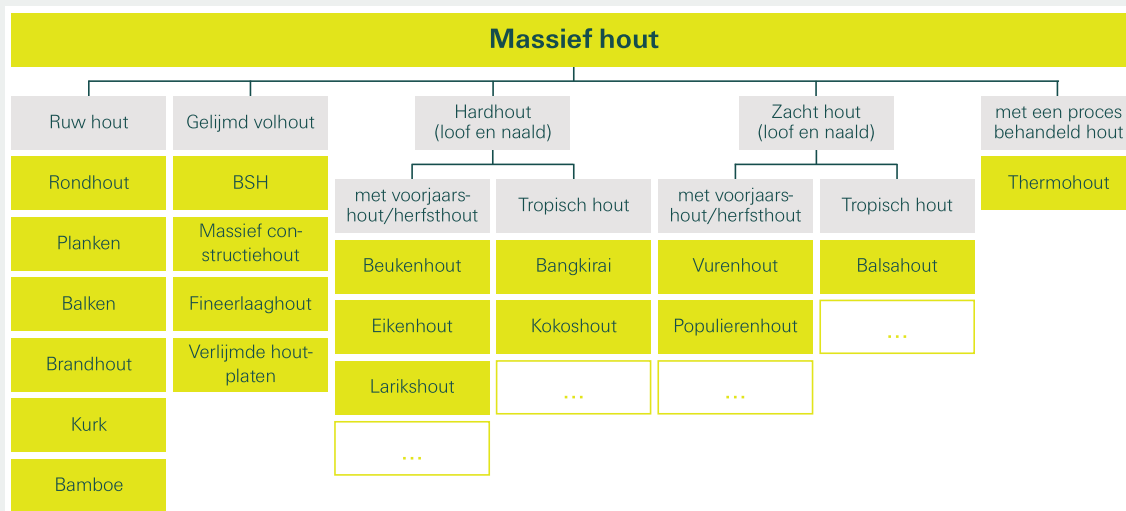
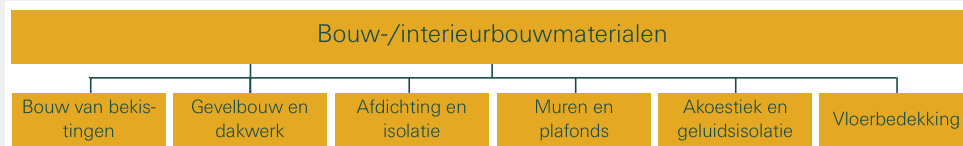
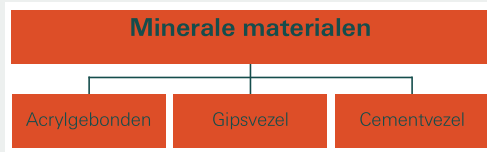

| Composietmaterialen                   |                                   |                                       |  |                                     |
|---------------------------------------|-----------------------------------|---------------------------------------|--|-------------------------------------|
| Materiaal op basis van hout/aluminium | Materiaal op basis van hout/staal | Materiaal op basis van hout/kunststof | Plaatmateriaal op basis van hout/bekleed | Materiaal op basis van hout/overige |
| Aluminium/PE                          | met dunne plaat-staalbekleding    | Hout/PMMA                             | gefineerd                                | Papier-honingraatplaat              |
| Aluminium/multiplex                   | met staalversterking              | HPL-beklede plaat                     | foliebekleed                             | Vlasplaat                           |
| Aluminium/HPL                         | ...                               | Met PE-folie ommanteld MDF-profiel    | papierbekleed                            | ...                                 |
| ...                                   |                                   | WPC                                   | melaminebekleed                          |                                     |
|                                       |                                   | MDF-PS-plaat                          | HPL/CPL-bekleed                          |                                     |
|                                       |                                   | ...                                   | ...                                      |                                     |

| Metalen           |                   |                         |
|-------------------|-------------------|-------------------------|
| Staal             | Non-Ferrometalen  |                         |
| Massief materiaal | Aluminium         | andere non-ferrometalen |
| Holprofiel        | Massief materiaal | Koper                   |
| Blik              | Holprofiel        | Zink                    |
| Rvs               | Blik              | Messing                 |
|                   | Schuim honingraat | Brons                   |

| Kunststof         |           |             |            |           |                     |                |                  |
|-------------------|-----------|-------------|------------|-----------|---------------------|----------------|------------------|
| Thermoplasten     |           |             |            |           | Duroplasten         |                | Elastomeren      |
| Massief materiaal | Folie     | Schuim      | Honingraat | Bekleding | Bekledingsmateriaal | Vezelversterkt | Rubber           |
| PMMA              | PVC-folie | PS kernlaag | PET-kern   | PVC-vinyl | HPL                 | GFK            | PU antislipmat   |
| PE Blockware      | ...       | ...         | ...        | ...       | Acrylharsplaat      | CFK            | Polyesterweefsel |
| PC-profiel        |           |             |            |           | Epoxyhars           | AFK            | ...              |
| ...               |           |             |            |           | ...                 | ...            |                  |



# CIRKELZAAGBLADEN

## Inhoud

|  |      |
|--|------|
| Handcirkelzaagbladen                         | 1-1  |
| Tafelcirkelzaagbladen voor standaardmachines | 1-15 |
| Platenopdeelzaagbladen                       | 1-37 |
| Cirkelzaagbladen voor speciale toepassingen  | 1-46 |



# HW HKS - Massief - Accuhandcirkelzagen

Handcirkelzaagbladen HW - vlakland - wisseltand



Product



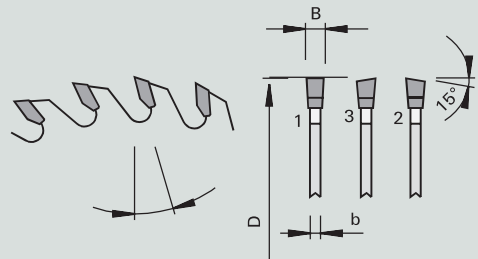

Tekening



Machine

Toepassing

Uitvoering



2-0-6



HW  
TC10

F-  
WS

- |   |   |  |  |
|---|---|--|--|
| <p>Machine / gebruiksaanwijzing</p> <ul style="list-style-type: none"> <li>• Accuhandcirkelzagen</li> <li>• Voor schulpen en afkorten van massief hout</li> </ul> | <p>Uitvoering</p> <ul style="list-style-type: none"> <li>• Tandvorm: wisseltand met vlakland 'WS-F'</li> <li>• Snijmateriaal HW TC10</li> </ul> | <p>Voordelen</p> <ul style="list-style-type: none"> <li>• Geringere vermogensopname door gereduceerde snijbreedte</li> </ul> | <p>Informatie - Tip</p> <ul style="list-style-type: none"> <li>• Geschikt voor accumachines</li> </ul> |
|---|---|--|--|

| Producteigenschappen |        |        |          |    |                |                          | Bestelinformatie |  |          |   |   |
|----------------------|--------|--------|----------|----|----------------|--------------------------|------------------|--|----------|---|---|
| Ø D [mm]             | B [mm] | b [mm] | Ø d [mm] | Z  | Snijkwaliteit* |                          | Spaanhoek [°]    |  | VE [St.] | V | Bestelnummer  |
| 136                  | 1,5    | 1,0    | 20       | 18 | ▲              | Dewalt                   | 20               |  | 1        |   | 58110400  |
| 136                  | 1,5    | 1,0    | 20       | 24 | ▲▲             | Dewalt                   | 20               |  | 1        |   | 58110401  |
| 160                  | 1,6    | 1,2    | 20       | 18 | ▲              | Mafell, Festool          | 20               |  | 1        |   | 58110413  |
| 160                  | 1,6    | 1,2    | 20       | 48 | ▲▲▲▲           | Mafell, Festool          | 20               |  | 1        | o | 58110419 <span style="color: red; font-weight: bold;">NEUW</span> |
| 165                  | 1,6    | 1,2    | 20       | 24 | ▲              | Makita, Festool, Bosch   | 20               |  | 1        | o | 58110423 <span style="color: red; font-weight: bold;">NEUW</span> |
| 165                  | 1,6    | 1,2    | 20       | 18 | ▲              | Makita, Dewalt, Bosch    | 20               |  | 1        |   | 58110402  |
| 165                  | 1,6    | 1,2    | 20       | 24 | ▲              | Makita, Dewalt, Bosch    | 20               |  | 1        |   | 58110403  |
| 165                  | 1,6    | 1,2    | 20       | 36 | ▲▲             | Makita, Dewalt, Bosch    | 20               |  | 1        |   | 58110404  |
| 165                  | 1,6    | 1,2    | 15,88    | 24 | ▲▲▲▲           | Milwaky                  | 20               |  | 1        | o | 58110421 <span style="color: red; font-weight: bold;">NEUW</span> |
| 165                  | 1,6    | 1,2    | 20       | 48 | ▲▲▲▲           | Makita, Dewalt, Bosch    | 20               |  | 1        | o | 58110420 <span style="color: red; font-weight: bold;">NEUW</span> |
| 165                  | 1,6    | 1,2    | 15,88    | 40 | ▲▲▲            | Milwaukee                | 15               |  | 1        |   | 58110405  |
| 184                  | 1,6    | 1,1    | 16       | 56 | ▲▲▲            | Dewalt                   | 15               |  | 1        |   | 58110406  |
| 184                  | 1,8    | 1,2    | 20       | 24 | ▲▲▲            | Mafell                   | 20               |  | 1        |   | 58110416 <span style="color: red; font-weight: bold;">NEUW</span> |
| 190                  | 1,8    | 1,2    | 30       | 48 | ▲▲▲▲           | Hilti                    | 15               |  | 1        | o | 58110418 <span style="color: red; font-weight: bold;">NEUW</span> |
| 190                  | 1,8    | 1,2    | 20       | 48 | ▲▲▲            | Dewalt                   | 15               |  | 1        |   | 58110407  |
| 190                  | 1,8    | 1,2    | 30       | 24 | ▲▲▲            | Hilti, Milwaukee, Dewalt | 20               |  | 1        |   | 58110417 <span style="color: red; font-weight: bold;">NEUW</span> |
| 210                  | 1,8    | 1,2    | 30       | 60 | ▲▲▲            | Dewalt Extrem            | 15               |  | 1        |   | 58110408  |
| 216                  | 2,0    | 1,4    | 30       | 24 | ▲              | Dewalt                   | 20               |  | 1        |   | 58110409  |
| 216                  | 2,0    | 1,4    | 30       | 36 | ▲▲             | Dewalt                   | 20               |  | 1        |   | 58110410  |
| 216                  | 2,0    | 1,4    | 30       | 60 | ▲▲▲            | Dewalt                   | 15               |  | 1        |   | 58110411  |
| 250                  | 2,2    | 1,6    | 30       | 24 | ▲              | Dewalt, ELU, Festo       | 20               |  | 1        |   | 58110412  |





\* Snijkwaliteit ▲ Zeer grove snede, ▲▲ Grove snede, ▲▲▲ Fijne snede, ▲▲▲▲ Zeer fijne snede

\*\* Extra gaten: Combi1 komt overeen met 2/10/60 + 2/7/42 Combi2 komt overeen met 2/7/42 + 2/9/46 en 2/10/60 Combi3 = 2/10/60 + 2/9/46 + 2/9,5/46,5 + 2/7/42 Combi5 = 2/7/110 + 2/9/110 + 2/8,4/130 + 2/14/110 + 4/9/100 + 4/19/120 Combi7 = 2/9/110 + 2/10/80 + 2/11/85 + 2/11/115 + 2/11/148 + 2/14/100 + 2/14/125 + 2/19/120

Geschikte reduceerringen vindt u aan het einde van dit hoofdstuk

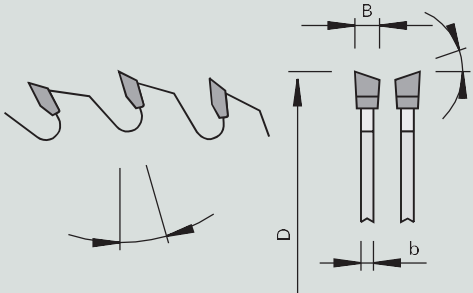
## HW HKS - Massief - Accuhandcirkelzagen

Handcirkelzaagbladen HW - wisseltand





|   |  |   |   |   |
|---|--|---|---|---|
| Product   | Tekening   | Machine   | Toepassing  | Uitvoering  |
|  |  |  |  |  |

|   |  |   |  |
|---|--|---|--|
| Machine / gebruiksaanwijzing  | Uitvoering   | Voordelen   | Informatie - Tip   |
| <ul style="list-style-type: none"> <li>• Accuhandcirkelzagen</li> <li>• Voor schulpen en afkorten van massief hout</li> </ul> | <ul style="list-style-type: none"> <li>• Tandvorm: wisseltand 'WS'</li> <li>• Snijmateriaal HW TC10</li> </ul> | <ul style="list-style-type: none"> <li>• Geringere vermogensopname door gereduceerde snijbreedte</li> </ul> | <ul style="list-style-type: none"> <li>• Geschikt voor accumachines</li> </ul> |

| Producteigenschappen |        |        |          |    |                |               | Bestelinformatie |   |              |              |
|----------------------|--------|--------|----------|----|----------------|---------------|------------------|---|--------------|--------------|
| Ø D [mm]             | B [mm] | b [mm] | Ø d [mm] | Z  | Snijkwaliteit* | Spaanhoek [°] | VE [St.]         | V | Bestelnummer |              |
| 190                  | 1,8    | 1,3    | 30       | 20 | ▲ Hilti        | 20            | 1                | o | 58110415     | <b>NIEUW</b> |

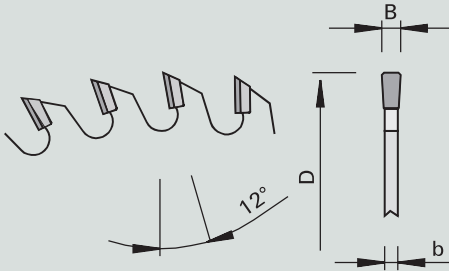
## DP HKS - DP - Accuhandcirkelzagen

Handcirkelzaagbladen DP - vlakland

|   |  |   |   |   |
|---|--|---|---|---|
| Product   | Tekening   | Machine   | Toepassing  | Uitvoering  |
|  |  |  |  |  |

|  |  |   |  |
|--|--|---|--|
| Machine / gebruiksaanwijzing   | Uitvoering   | Voordelen   | Informatie - Tip   |
| <ul style="list-style-type: none"> <li>• Accuhandcirkelzagen</li> <li>• Voor zaagsneden in cementgebonden plaatmaterialen</li> </ul> | <ul style="list-style-type: none"> <li>• Tandvorm: vlakland 'F'</li> <li>• Snijmateriaal: DP</li> <li>• Stamblad gecoat</li> </ul> | <ul style="list-style-type: none"> <li>• Geringere vermogensopname door gereduceerde snijbreedte</li> </ul> | <ul style="list-style-type: none"> <li>• Niet te gebruiken voor steen, glas en nagels/ spijkers</li> <li>• Geschikt voor accumachines</li> </ul> |

| Producteigenschappen |        |        |          |   |                |               | Bestelinformatie |   |              |              |
|----------------------|--------|--------|----------|---|----------------|---------------|------------------|---|--------------|--------------|
| Ø D [mm]             | B [mm] | b [mm] | Ø d [mm] | Z | Snijkwaliteit* | Spaanhoek [°] | VE [St.]         | V | Bestelnummer |              |
| 136                  | 1,6    | 1,2    | 20       | 4 | ▲              | 12            | 1                | o | 50460500     | <b>NIEUW</b> |
| 160                  | 1,6    | 1,2    | 20       | 6 | ▲              | 12            | 1                | o | 50460479     | <b>NIEUW</b> |
| 165                  | 1,6    | 1,2    | 20       | 6 | ▲              | 12            | 1                | o | 50460480     | <b>NIEUW</b> |





\* Snijkwaliteit ▲ Zeer grove snede, ▲▲ Grove snede, ▲▲▲ Fijne snede, ▲▲▲▲ Zeer fijne snede

\*\* Extra gaten: Combi1 komt overeen met 2/10/60 + 2/7/42 Combi2 komt overeen met 2/7/42 + 2/9/46 en 2/10/60 Combi3 = 2/10/60 + 2/9/46 + 2/9.5/46.5 + 2/7/42 Combi5 = 2/7/110 + 2/9/110 + 2/8.4/130 + 2/14/110 + 4/9/100 + 4/19/120 Combi7 = 2/9/110 + 2/10/80 + 2/11/85 + 2/11/115 + 2/11/148 + 2/14/100 + 2/14/125 + 2/19/120

Geschikte **reduceringen** vindt u aan het einde van dit hoofdstuk

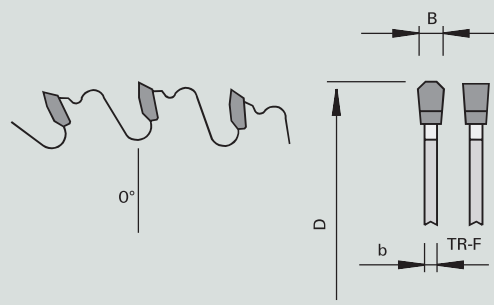
# HT HKS - Mega-Steel - Accuhandcirkelzagen

Metaal-afkortcirkelzaagbladen HT - spaanhoek neutraal

|  |  |   |
|--|--|---|
| <p>Product</p>  | <p>Tekening</p>  | <p>Machine</p>  <p>Toepassing</p>  <p>Uitvoering</p>  <p>3-0-1</p> <p>HW<br/>TCx03</p> <p>TR-F</p> |
|--|--|---|

|   |  |   |   |
|---|--|---|---|
| <p>Machine / gebruiksaanwijzing</p> <ul style="list-style-type: none"> <li>• Dry-cut (Droogzaag) machines</li> <li>• Universeel metaalzaagmachines</li> <li>• Voor zaagsneden in samengestelde materialen, edelstaal, lood, kunststoffen, Ne-materialen, kabelgoten, kabel, profielen, SML-buis etc.</li> </ul> | <p>Uitvoering</p> <ul style="list-style-type: none"> <li>• tandvorm: trapezium-vlaktand 'TR-F'</li> <li>• Snijmateriaal: HT TCx03</li> </ul> | <p>Voordelen</p> <ul style="list-style-type: none"> <li>• Droog zagen</li> <li>• Optimale snijkwaliteit</li> <li>• Extreem lange standtijd</li> </ul> | <p>Informatie - Tip</p> <ul style="list-style-type: none"> <li>• Geschikt voor ACCU machines</li> <li>• alt. Parat - Negativ (HKS) en Unisteel (HKS)</li> <li>• aanbev. 1/min (RPM):</li> <li>• Ø160 = 2750 min-1</li> <li>• Ø190 = 2350 min-1</li> <li>• Ø216 = 2050 min-1</li> <li>• Ø230 = 1950 min-1</li> </ul> |
|---|--|---|---|

| Producteigenschappen |        |        |          |    |                |               | Bestelinformatie |   |              |  |
|----------------------|--------|--------|----------|----|----------------|---------------|------------------|---|--------------|--|
| Ø D [mm]             | B [mm] | b [mm] | Ø d [mm] | Z  | Snijkwaliteit* | Spaanhoek [°] | VE [St.]         | V | Bestelnummer |  |
| 160                  | 1,8    | 1,4    | 20       | 40 | ▲▲             | 0             | 1                |   | 58458784     |  |
| 190                  | 1,8    | 1,4    | 30       | 48 | ▲▲             | 0             | 1                |   | 58458785     |  |
| 216                  | 1,8    | 1,4    | 30       | 56 | ▲▲             | 0             | 1                |   | 58458786     |  |
| 230                  | 1,8    | 1,4    | 30       | 60 | ▲▲             | 0             | 1                |   | 58805879     |  |

\* Snijkwaliteit ▲ Zeer grove snede, ▲▲ Grove snede, ▲▲▲ Fijne snede, ▲▲▲▲ Zeer fijne snede

\*\* Extra gaten: Combi1 komt overeen met 2/10/60 + 2/7/42 Combi2 komt overeen met 2/7/42 + 2/9/46 en 2/10/60 Combi3 = 2/10/60 + 2/9/46 + 2/9,5/46,5 + 2/7/42 Combi5 = 2/7/110 + 2/9/110 + 2/8,4/130 + 2/14/110 + 4/9/100 + 4/19/120 Combi7 = 2/9/110 + 2/10/80 + 2/11/85 + 2/11/115 + 2/11/148 + 2/14/100 + 2/14/125 + 2/19/120

Geschikte reduceerringen vindt u aan het einde van dit hoofdstuk



# HW HKS - Unisteeel - Accuhandcirkelzagen

Handcirkelzaagblad HW - trapezium-vlaktand

Product



Tekening

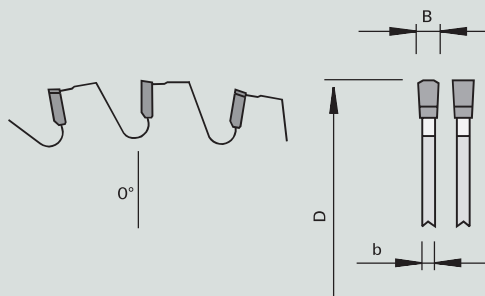

Machine



Toepassing



Uitvoering

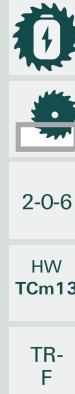

Machine / gebruiksaanwijzing

- Accuhandcirkelzagen
- Voor doorsnijden van metalen en non-ferro-metalen (zink), gietijzer enz.

Uitvoering

- Tandvorm: trapezium met vlaktand 'TR-F'
- Snijmateriaal: HW TCm13

Voordelen

- Geringere vermogensopname door gereduceerde snijbreedte

Informatie - Tip

- Geschikt voor accumachines

Producteigenschappen

Bestelinformatie

| Ø D [mm] | B [mm] | b [mm] | Ø d [mm] | Z  | Snijkwaliteit* |                 | Spaanhoek [°] |  | VE [St.] | V | Bestelnummer   |
|----------|--------|--------|----------|----|----------------|-----------------|---------------|--|----------|---|--|
| 136      | 1,6    | 1,2    | 20       | 36 | ▲▲             | Dewalt          | 0             |  | 1        |   | 58116400 <span style="color: red; font-weight: bold;">NIEUW</span> |
| 160      | 1,6    | 1,2    | 20       | 40 | ▲▲             | Mafell, Festool | 0             |  | 1        | o | 58116402 <span style="color: red; font-weight: bold;">NIEUW</span> |
| 165      | 1,6    | 1,2    | 20       | 40 | ▲▲             | Makita, Dewalt  | 0             |  | 1        |   | 58116401 <span style="color: red; font-weight: bold;">NIEUW</span> |

\* Snijkwaliteit ▲ Zeer grove snede, ▲▲ Grove snede, ▲▲▲ Fijne snede, ▲▲▲▲ Zeer fijne snede





\*\* Extra gaten: Combi1 komt overeen met 2/10/60 + 2/7/42 Combi2 komt overeen met 2/7/42 + 2/9/46 en 2/10/60 Combi3 = 2/10/60 + 2/9/46 + 2/9.5/46.5 + 2/7/42 Combi5 = 2/7/110 + 2/9/110 + 2/8.4/130 + 2/14/110 + 4/9/100 + 4/19/120 Combi7 = 2/9/110 + 2/10/80 + 2/11/85 + 2/11/115 + 2/11/148 + 2/14/100 + 2/14/125 + 2/19/120

Geschikte reduceerringen vindt u aan het einde van dit hoofdstuk

HW

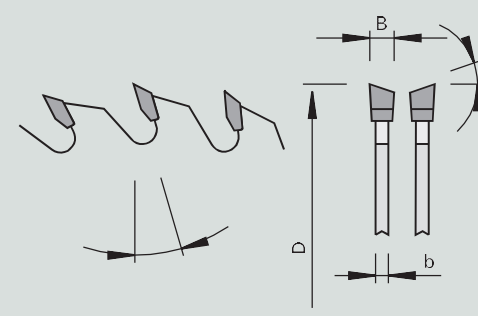
**HKS - Massief**

Handcirkelzaagbladen HW - wisseltand

|  |  |  |   |  |
|--|--|--|---|--|
| <p>Product</p>  | <p>Tekening</p>  | <p>Machine</p>  | <p>Toepassing</p>  | <p>Uitvoering</p> <p>1-0-1</p>  <p>HW<br/><b>TC10</b></p> <p>WS</p> |
|--|--|--|---|--|

|  |   |                  |   |
|--|---|------------------|---|
| <p>Machine / gebruiksaanwijzing</p> <ul style="list-style-type: none"> <li>• Handcirkelzagen</li> <li>• Kap- en radiaal cirkelzagen</li> <li>• Voor schulpen en afkorten van massief hout</li> </ul> | <p>Uitvoering</p> <ul style="list-style-type: none"> <li>• Tandvorm: wisseltand "WS"</li> <li>• Tandbezetting: HW TC10</li> </ul> | <p>Voordelen</p> | <p>Informatie - Tip</p> <ul style="list-style-type: none"> <li>• Grotere maten zie ZQW</li> </ul> |
|--|---|------------------|---|

| Producteigenschappen |        |        |          |    | Bestelinformatie |          |               |          |   |              |
|----------------------|--------|--------|----------|----|------------------|----------|---------------|----------|---|--------------|
| Ø D [mm]             | B [mm] | b [mm] | Ø d [mm] | Z  | Snijkwaliteit*   | NL**     | Spaanhoek [°] | VE [St.] | V | Bestelnummer |
| 120                  | 1,8    | 1,3    | 20       | 24 | ▲▲               |          | 15            | 1        |   | 50104061     |
| 125                  | 2,4    | 1,6    | 20       | 20 | ▲▲▲              | 2/5,5/30 | 15            | 1        |   | 50110011     |
| 130                  | 2,4    | 1,6    | 20       | 20 | ▲▲▲              | 2/6/32,5 | 15            | 1        |   | 50110017     |
| 140                  | 2,4    | 1,6    | 20       | 20 | ▲▲▲              | 2/6/32,5 | 15            | 1        |   | 50110028     |
| 140                  | 2,4    | 1,6    | 20       | 12 | ▲                | 2/6/32,5 | 20            | 1        |   | 50110242     |
| 150                  | 2,6    | 1,6    | 20       | 24 | ▲▲▲              | 2/6/32,5 | 15            | 1        |   | 50110039     |
| 150                  | 2,6    | 1,6    | 20       | 12 | ▲                | 2/6/32,5 | 20            | 1        |   | 50110243     |
| 150                  | 2,6    | 1,6    | 30       | 24 | ▲▲▲              | 2/7/42   | 15            | 1        |   | 50110042     |
| 152                  | 2,6    | 1,6    | 20       | 24 | ▲▲               |          | 15            | 1        |   | 58114125     |
| 160                  | 2,6    | 1,6    | 16       | 24 | ▲▲▲              | 2/6/32,5 | 15            | 1        |   | 50110051     |
| 160                  | 2,2    | 1,6    | 20       | 24 | ▲▲▲              | 2/6/32,5 | 15            | 1        |   | 50110054     |
| 160                  | 2,2    | 1,6    | 20       | 12 | ▲                | 2/6/32,5 | 20            | 1        |   | 50110244     |
| 160                  | 2,6    | 1,6    | 30       | 24 | ▲▲▲              | 2/7/42   | 15            | 1        |   | 50110057     |
| 165                  | 2,6    | 1,6    | 20       | 24 | ▲                | 2/6/32,5 | 15            | 1        |   | 50110060     |
| 165                  | 2,6    | 1,6    | 30       | 24 | ▲                | 2/7/42   | 15            | 1        |   | 50110130     |
| 170                  | 2,6    | 1,6    | 30       | 24 | ▲▲▲              | 2/7/42   | 20            | 1        |   | 50110069     |
| 180                  | 2,6    | 1,6    | 16       | 24 | ▲▲▲              | 2/6/32,5 | 15            | 1        |   | 50110081     |
| 180                  | 2,6    | 1,6    | 20       | 24 | ▲▲▲              | 2/6/32,5 | 20            | 1        |   | 50110075     |
| 180                  | 2,6    | 1,6    | 20       | 14 | ▲                | 2/6/32,5 | 20            | 1        |   | 50110247     |
| 180                  | 2,6    | 1,6    | 30       | 24 | ▲▲▲              | 2/7/42   | 20            | 1        |   | 50110078     |
| 180                  | 2,6    | 1,6    | 30       | 14 | ▲                | 2/7/42   | 20            | 1        |   | 50110248     |
| 184                  | 2,6    | 1,6    | 20       | 24 | ▲▲▲              | 2/6/32,5 | 15            | 1        | o | 50110082     |
| 184                  | 2,6    | 1,6    | 16       | 40 | ▲▲▲▲             | 2/6/32,5 | 15            | 1        | o | 50110282     |
| 190                  | 2,6    | 1,6    | 16       | 24 | ▲▲▲              | 2/6/32,5 | 15            | 1        |   | 50110153     |
| 190                  | 2,6    | 1,6    | 20       | 16 | ▲                | 2/6/32,5 | 20            | 1        | o | 50110250     |
| 190                  | 2,6    | 1,6    | 20       | 24 | ▲▲▲              | 2/6/32,5 | 15            | 1        |   | 50110154     |
| 190                  | 2,6    | 1,6    | 30       | 24 | ▲▲▲              | 2/7/42   | 20            | 1        |   | 50110155     |
| 190                  | 2,6    | 1,6    | 30       | 16 | ▲                | 2/7/42   | 20            | 1        |   | 50110251     |
| 190                  | 2,6    | 1,6    | 30       | 24 | ▲▲▲              |          | 15            | 1        |   | 58114105     |
| 200                  | 2,8    | 1,8    | 30       | 30 | ▲▲▲▲             | 2/7/42   | 15            | 1        |   | 50110095     |
| 203                  | 2,7    | 1,8    | 30       | 24 | ▲▲▲              |          | 15            | 1        |   | 58114132     |
| 200                  | 2,8    | 1,8    | 30       | 18 | ▲                | 2/7/42   | 20            | 1        |   | 50110252     |
| 205                  | 2,6    | 1,8    | 18       | 30 | ▲▲▲▲             |          | 15            | 1        |   | 50110286     |
| 210                  | 2,8    | 1,8    | 30       | 30 | ▲▲▲▲             | 2/7/42   | 15            | 1        |   | 50110104     |
| 210                  | 2,8    | 1,8    | 30       | 18 | ▲                | 2/7/42   | 20            | 1        |   | 50110253     |
| 216                  | 2,8    | 1,8    | 30       | 30 | ▲▲▲▲             | 2/7/42   | 20            | 1        |   | 50110107     |
| 220                  | 2,8    | 1,8    | 30       | 36 | ▲▲▲▲             | 2/7/42   | 15            | 1        |   | 50110110     |
| 220                  | 2,8    | 1,8    | 30       | 24 | ▲▲               | 2/7/42   | 15            | 1        |   | 50110164     |
| 225                  | 2,8    | 1,8    | 30       | 24 | ▲▲               | 2/7/42   | 15            | 1        |   | 50110165     |

\* Snijkwaliteit ▲ Zeer grove snede, ▲▲ Grove snede, ▲▲▲ Fijne snede, ▲▲▲▲ Zeer fijne snede

\*\* Extra gaten: Combi1 komt overeen met 2/10/60 + 2/7/42 Combi2 komt overeen met 2/7/42 + 2/9/46 en 2/10/60 Combi3 = 2/10/60 + 2/9/46 + 2/9,5/46,5 + 2/7/42 Combi5 = 2/7/110 + 2/9/110 + 2/8,4/130 + 2/14/110 + 4/9/100 + 4/19/120 Combi7 = 2/9/110 + 2/10/80 + 2/11/85 + 2/11/115 + 2/11/148 + 2/14/100 + 2/14/125 + 2/19/120

Geschikte reduceerringen vindt u aan het einde van dit hoofdstuk

| Producteigenschappen |        |        |          |    |                |        |               | Bestelinformatie |          |   |              |
|----------------------|--------|--------|----------|----|----------------|--------|---------------|------------------|----------|---|--------------|
| Ø D [mm]             | B [mm] | b [mm] | Ø d [mm] | Z  | Snijkwaliteit* | NL**   | Spaanhoek [°] |                  | VE [St.] | V | Bestelnummer |
| 225                  | 2,8    | 1,8    | 30       | 34 | ▲▲▲            | 2/7/42 | 15            |                  | 1        |   | 50110228     |
| 230                  | 2,8    | 1,8    | 30       | 36 | ▲▲▲            | 2/7/42 | 15            |                  | 1        |   | 50110113     |
| 230                  | 2,8    | 1,8    | 30       | 24 | ▲▲             | 2/7/42 | 15            |                  | 1        |   | 50110168     |
| 230                  | 2,8    | 1,8    | 30       | 18 | ▲              | 2/7/42 | 20            |                  | 1        |   | 50110255     |
| 240                  | 3,0    | 2,0    | 30       | 64 | ▲▲▲            | 2/7/42 | 20            |                  | 1        | o | 50687903     |

## HW HKS - Board Handcirkelzaagbladen HW - wisseltand

Product



Tekening

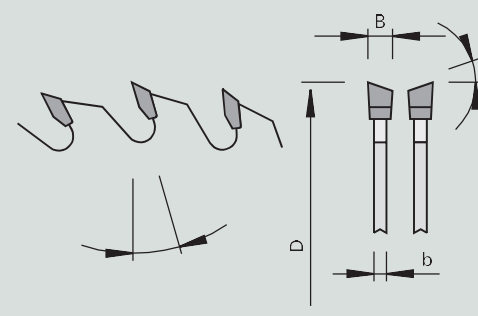

Machine



Toepassing



Uitvoering

1-0-1

HW TC10

WS

|  |  |                  |   |
|--|--|------------------|---|
| <p>Machine / gebruiksaanwijzing</p> <ul style="list-style-type: none"> <li>• Handcirkelzagen</li> <li>• Kap- en radiaal cirkelzagen</li> <li>• Voor schulpen en afkorten van plaatmateriaal op basis van hout</li> </ul> | <p>Uitvoering</p> <ul style="list-style-type: none"> <li>• Tandvorm: wisseltand 'WS'</li> <li>• Snijmateriaal HW TC10</li> </ul> | <p>Voordelen</p> | <p>Informatie - Tip</p> <ul style="list-style-type: none"> <li>• Grotere maten zie ZWS</li> </ul> |
|--|--|------------------|---|

| Producteigenschappen |        |        |          |          |                |          |               | Bestelinformatie |          |              |  |
|----------------------|--------|--------|----------|----------|----------------|----------|---------------|------------------|----------|--------------|--|
| Ø D [mm]             | B [mm] | b [mm] | Ø d [mm] | Z        | Snijkwaliteit* | NL**     | Spaanhoek [°] |                  | VE [St.] | Bestelnummer |  |
| 100                  | 2,4    | 1,4    | 12       | 30       | ▲▲▲            |          | 10            |                  | 1        | 50110001     |  |
| 100                  | 2,4    | 1,4    | 22       | 30       | ▲▲▲            |          | 10            |                  | 1        | 50110003     |  |
| 105                  | 2,4    | 1,4    | 22       | 30       | ▲▲▲            |          | 10            |                  | 1        | 50110006     |  |
| 125                  | 2,4    | 1,6    | 20       | 36       | ▲▲▲            | 2/6/32,5 | 10            |                  | 1        | 50110012     |  |
| 130                  | 2,4    | 1,6    | 20       | 36       | ▲▲             | 2/6/32,5 | 10            |                  | 1        | 50110018     |  |
| 140                  | 2,4    | 1,6    | 20       | 36       | ▲▲▲            | 2/6/32,5 | 10            |                  | 1        | 50110029     |  |
| 150                  | 2,6    | 1,6    | 20       | 36       | ▲▲▲            | 2/6/32,5 | 15            |                  | 1        | 50110040     |  |
| 150                  | 2,6    | 1,6    | 20       | 48       | ▲▲▲▲           | 2/6/32,5 | 10            |                  | 1        | 50110041     |  |
| 160                  | 2,6    | 1,6    | 16       | 48       | ▲▲▲▲           | 2/6/32,5 | 10            |                  | 1        | 50110053     |  |
| 160                  | 2,2    | 1,6    | 20       | 36       | ▲▲▲            | 2/6/32,5 | 15            |                  | 1        | 50110055     |  |
| 160                  | 2,2    | 1,6    | 20       | 48       | ▲▲▲▲           | 2/6/32,5 | 10            |                  | 1        | 50110056     |  |
| 160                  | 2,2    | 1,6    | 20       | 48 Vario | ▲▲▲▲           | 2/6/32,5 | 5             |                  | 1        | 58110356     |  |
| 160                  | 2,6    | 1,6    | 30       | 36       | ▲▲▲            | 2/7/42   | 15            |                  | 1        | 50110058     |  |
| 160                  | 2,6    | 1,6    | 30       | 48       | ▲▲▲▲           | 2/7/42   | 10            |                  | 1        | 50110059     |  |
| 165                  | 2,6    | 1,6    | 20       | 36       | ▲▲▲            | 2/6/32,5 | 15            |                  | 1        | 50110061     |  |
| 165                  | 2,6    | 1,6    | 20       | 48       | ▲▲▲▲           | 2/6/32,5 | 10            |                  | 1        | 50110062     |  |
| 170                  | 2,6    | 1,6    | 30       | 36       | ▲▲▲            | 2/7/42   | 15            |                  | 1        | 50110070     |  |
| 170                  | 2,6    | 1,6    | 30       | 48       | ▲▲▲▲           | 2/7/42   | 10            |                  | 1        | 50110071     |  |
| 180                  | 2,6    | 1,6    | 16       | 48       | ▲▲▲▲           | 2/6/32,5 | 10            |                  | 1        | 50110183     |  |
| 180                  | 2,6    | 1,6    | 20       | 40       | ▲▲▲            | 2/6/32,5 | 15            |                  | 1        | 50110076     |  |
| 180                  | 2,6    | 1,6    | 30       | 40       | ▲▲▲            | 2/7/42   | 15            |                  | 1        | 50110079     |  |
| 180                  | 2,6    | 1,6    | 30       | 54       | ▲▲▲▲           | 2/7/42   | 10            |                  | 1        | 50110080     |  |
| 180                  | 2,6    | 1,6    | 20       | 54       | ▲▲▲▲           |          | 10            |                  | 1        | 50110077     |  |
| 190                  | 2,6    | 1,6    | 16       | 30       | ▲▲▲            | 2/6/32,5 | 15            |                  | 1        | 50110083     |  |
| 190                  | 2,6    | 1,6    | 16       | 42       | ▲▲▲▲           | 2/6/32,5 | 10            |                  | 1        | 50110084     |  |
| 190                  | 2,6    | 1,6    | 20       | 30       | ▲▲▲            | 2/6/32,5 | 15            |                  | 1        | 50110086     |  |
| 190                  | 2,6    | 2,0    | 20FX     | 32       | ▲▲▲            | Fast-Fix | 10            |                  | 1        | 50110266     |  |
| 190                  | 2,6    | 2,0    | 20FX     | 48       | ▲▲▲▲           | Fast-Fix | 10            |                  | 1        | 50110267     |  |
| 190                  | 2,6    | 2,0    | 20FX     | 60       | ▲▲▲            | Fast-Fix | 10            |                  | 1        | 50110268     |  |
| 190                  | 2,6    | 1,6    | 20       | 48       | ▲▲▲▲           | 2/6/32,5 | 10            |                  | 1        | 50110087     |  |

\* Snijkwaliteit ▲ Zeer grove snede, ▲▲ Grove snede, ▲▲▲ Fijne snede, ▲▲▲▲ Zeer fijne snede  
 \*\* Extra gaten: Combi1 komt overeen met 2/10/60 + 2/7/42 Combi2 komt overeen met 2/7/42 + 2/9/46 en 2/10/60 Combi3 = 2/10/60 + 2/9/46 + 2/9,5/46,5 + 2/7/42 Combi5 = 2/7/110 + 2/9/110 + 2/8,4/130 + 2/14/110 + 4/9/100 + 4/19/120 Combi7 = 2/9/110 + 2/10/80 + 2/11/85 + 2/11/115 + 2/11/148 + 2/14/100 + 2/14/125 + 2/19/120  
 Geschikte reduceerringen vindt u aan het einde van dit hoofdstuk

| Producteigenschappen |        |        |          |    |                |        |               | Bestelinformatie |              |  |
|----------------------|--------|--------|----------|----|----------------|--------|---------------|------------------|--------------|--|
| Ø D [mm]             | B [mm] | b [mm] | Ø d [mm] | Z  | Snijkwaliteit* | NL**   | Spaanhoek [°] | VE [St.]         | Bestelnummer |  |
| 190                  | 2,6    | 1,6    | 30       | 30 | ▲▲▲            | 2/7/42 | 15            | 1                | 50110089     |  |
| 190                  | 2,6    | 1,6    | 30       | 48 | ▲▲▲▲           | 2/7/42 | 10            | 1                | 50110090     |  |
| 190                  | 2,6    | 1,6    | 30       | 60 | ▲▲▲▲           | 2/7/42 | 10            | 1                | 50110091     |  |
| 200                  | 2,8    | 1,8    | 30       | 48 | ▲▲▲▲           | 2/7/42 | 15            | 1                | 50110096     |  |
| 200                  | 2,8    | 1,8    | 30       | 60 | ▲▲▲▲           | 2/7/42 | 10            | 1                | 50110097     |  |
| 210                  | 2,8    | 1,8    | 30       | 48 | ▲▲▲▲           | 2/7/42 | 15            | 1                | 50110105     |  |
| 210                  | 2,8    | 1,8    | 30       | 60 | ▲▲▲▲           | 2/7/42 | 10            | 1                | 50110106     |  |
| 216                  | 2,8    | 1,8    | 30       | 48 | ▲▲▲▲           | 2/7/42 | 15            | 1                | 50110108     |  |
| 216                  | 2,8    | 1,8    | 30       | 60 | ▲▲▲▲           | 2/7/42 | 10            | 1                | 50110109     |  |
| 220                  | 2,8    | 1,8    | 30       | 48 | ▲▲▲▲           | 2/7/42 | 15            | 1                | 50110111     |  |
| 220                  | 2,8    | 1,8    | 30       | 64 | ▲▲▲▲           | 2/7/42 | 10            | 1                | 50110112     |  |
| 225                  | 2,8    | 1,8    | 30       | 48 | ▲▲▲▲           | 2/7/42 | 10            | 1                | 50110237     |  |
| 225                  | 2,6    | 1,8    | 30       | 64 | ▲▲▲▲           | 2/7/42 | 10            | 1                | 50687902     |  |
| 230                  | 2,8    | 1,8    | 30       | 48 | ▲▲▲▲           | 2/7/42 | 15            | 1                | 50110114     |  |
| 230                  | 2,8    | 1,8    | 30       | 64 | ▲▲▲▲           | 2/7/42 | 10            | 1                | 50110115     |  |

## DP HKS - LR Handcirkelzaagbladen DP - vlakland

Product



Tekening

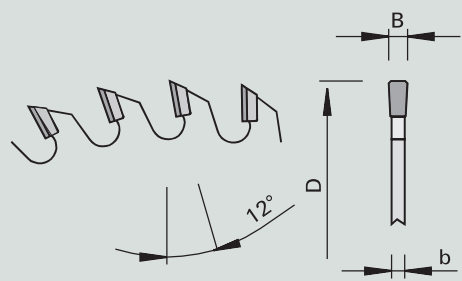

Machine



Toepassing



Uitvoering



0,0 mm

1-0-1

F

- |   |  |  |   |
|---|--|--|---|
| <p>Machine / gebruiksaanwijzing</p> <ul style="list-style-type: none"> <li>• Handcirkelzaagbladen</li> <li>• Voor zaagsneden in cementgebonden plaatmaterialen</li> </ul> | <p>Uitvoering</p> <ul style="list-style-type: none"> <li>• Tandvorm: vlakland 'F'</li> <li>• Snijmateriaal: DP</li> <li>• Stamblad gecoat</li> </ul> | <p>Voordelen</p> <ul style="list-style-type: none"> <li>• Uitstekende spaanafvoer door grote spaanruimten</li> <li>• Betere verspaning door grote spaanhoek</li> </ul> | <p>Informatie - Tip</p> <ul style="list-style-type: none"> <li>• Niet inzetbaar voor steen, glas en nagels/ spijkers</li> </ul> |
|---|--|--|---|

| Producteigenschappen |        |        |          |   |                |          |               | Bestelinformatie |   |              |
|----------------------|--------|--------|----------|---|----------------|----------|---------------|------------------|---|--------------|
| Ø D [mm]             | B [mm] | b [mm] | Ø d [mm] | Z | Snijkwaliteit* | NL**     | Spaanhoek [°] | VE [St.]         | V | Bestelnummer |
| 160                  | 2,2    | 1,6    | 20       | 4 | ▲              | 2/6/32,5 | 12            | 1                |   | 50457997     |
| 190                  | 2,2    | 1,6    | 30       | 4 | ▲              | 2/7/42   | 12            | 1                |   | 50457994     |
| 230                  | 2,2    | 1,6    | 30       | 4 | ▲              | Combi3   | 12            | 1                |   | 50457992     |

\* Snijkwaliteit ▲ Zeer grove snede, ▲▲ Grove snede, ▲▲▲ Fijne snede, ▲▲▲▲ Zeer fijne snede

\*\* Extra gaten: Combi1 komt overeen met 2/10/60 + 2/7/42 Combi2 komt overeen met 2/7/42 + 2/9/46 en 2/10/60 Combi3 = 2/10/60 + 2/9/46 + 2/9,5/46,5 + 2/7/42 Combi5 = 2/7/110 + 2/9/110 + 2/8,4/130 + 2/14/110 + 4/9/100 + 4/19/120 Combi7 = 2/9/110 + 2/10/80 + 2/11/85 + 2/11/115 + 2/11/148 + 2/14/100 + 2/14/125 + 2/19/120

Geschikte reduceerringen vindt u aan het einde van dit hoofdstuk

**DP** **HKS - L**  
Handcirkelzaagbladen DP - vlakland

Product



Tekening

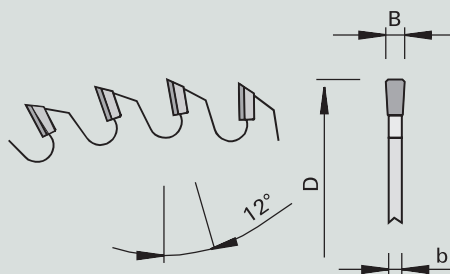

Machine



Toepassing



Uitvoering



Machine / gebruiksaanwijzing

- Handcirkelzaagbladen
- Voor door- en bijzagen van laminaat, MDF, spaanplaat, cementgebonden platen, Corian®, Duroplast, gipsplaten en Melamine

Uitvoering

- Tandvorm: vlakland 'F'
- Snijmateriaal: DP
- Naslijpzone 1,0 mm
- Stamblad gecoat

Voordelen

- Uitstekende spaanafvoer door grote spaanruimten
- Betere verspaning door grote spaanhoek

Informatie - Tip

- Laag aantal tanden voor schulpen
- Hoog aantal tanden voor formaatsneden
- Niet te gebruiken voor steen, glas en nagels/ spijkers

Producteigenschappen

| Ø D [mm] | B [mm] | b [mm] | Ø d [mm] | Z  | Snijkwaliteit* | NL**     | Spaanhoek [°] | VE [St.] | V | Bestelnummer         |
|----------|--------|--------|----------|----|----------------|----------|---------------|----------|---|----------------------|
| 120      | 2,2    | 1,6    | 20       | 6  | ▲              | 2/7/42   | 12            | 1        | o | 50457378             |
| 160      | 2,2    | 1,6    | 20       | 8  | ▲              | 2/6/32,5 | 12            | 1        |   | 50457379             |
| 160      | 2,2    | 1,6    | 20       | 30 | ▲▲▲            | 2/6/32,5 | 8             | 1        |   | 50458171             |
| 160      | 2,2    | 1,6    | 30       | 8  | ▲              | 2/7/42   | 12            | 1        | o | 50457377             |
| 190      | 2,2    | 1,6    | 30       | 30 | ▲▲▲            | 2/7/42   | 12            | 1        |   | 58457361 <b>NIUW</b> |
| 190      | 2,2    | 1,6    | 30       | 8  | ▲              | 2/7/42   | 12            | 1        |   | 50457357             |
| 210      | 2,2    | 1,6    | 30       | 12 | ▲              | Combi3   | 12            | 1        |   | 50457358             |
| 216      | 2,2    | 1,6    | 30       | 12 | ▲              | Combi3   | 12            | 1        |   | 50458137             |
| 230      | 2,2    | 1,6    | 30       | 15 | ▲              | Combi3   | 12            | 1        |   | 50457359             |
| 230      | 2,2    | 1,6    | 30       | 30 | ▲▲             | Combi3   | 12            | 1        |   | 50457362             |
| 250      | 2,2    | 1,6    | 30       | 16 | ▲              | Combi3   | 12            | 1        |   | 50457360             |
| 250      | 2,2    | 1,6    | 30       | 40 | ▲▲▲            | Combi3   | 8             | 1        | o | 50458000             |
| 300      | 2,2    | 1,6    | 30       | 36 | ▲              | Combi3   | 12            | 1        |   | 50457557             |
| 300      | 2,2    | 1,6    | 30       | 48 | ▲▲             | Combi3   | 8             | 1        | o | 50457545             |

\* Snijkwaliteit ▲ Zeer grove snede, ▲▲ Grove snede, ▲▲▲ Fijne snede, ▲▲▲▲ Zeer fijne snede





\*\* Extra gaten: Combi1 komt overeen met 2/10/60 + 2/7/42 Combi2 komt overeen met 2/7/42 + 2/9/46 en 2/10/60 Combi3 = 2/10/60 + 2/9/46 + 2/9.5/46.5 + 2/7/42 Combi5 = 2/7/110 + 2/9/110 + 2/8.4/130 + 2/14/110 + 4/9/100 + 4/19/120 Combi7 = 2/9/110 + 2/10/80 + 2/11/85 + 2/11/115 + 2/11/148 + 2/14/100 + 2/14/125 + 2/19/120

Geschikte reduceerringen vindt u aan het einde van dit hoofdstuk

DP

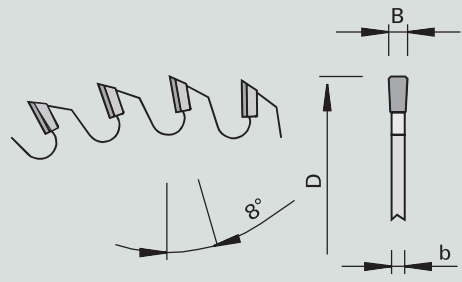
HKS - L2

Handcirkelzaagbladen DP - vlakland met fase

|  |  |  |   |   |
|--|--|--|---|---|
| <p>Product</p>  | <p>Tekening</p>  | <p>Machine</p>  | <p>Toepassing</p>  | <p>Uitvoering</p>  |
|--|--|--|---|---|

|  |  |  |  |
|--|--|--|--|
| <p>Machine / gebruiksaanwijzing</p> <ul style="list-style-type: none"> <li>• Handcirkelzaagbladen</li> <li>• Voor formaatsneden in laminaat, MDF, spaanplaat, cementgebonden platen, Corian®, Duroplast, gipsplaten en Melamine</li> </ul> | <p>Uitvoering</p> <ul style="list-style-type: none"> <li>• Tandvorm: vlakland met fase 'F-FA'</li> <li>• Snijmateriaal: DP</li> <li>• Naslijpzone 2,5 mm</li> <li>• Stamblad gecoat</li> </ul> | <p>Voordelen</p> <ul style="list-style-type: none"> <li>• Uitstekende spaanafvoer door grote spaanruimte</li> <li>• Stabiele uitvoering</li> </ul> | <p>Informatie - Tip</p> <ul style="list-style-type: none"> <li>• Laag aantal tanden voor schulpen</li> <li>• Hoog aantal tanden voor formaatsneden</li> <li>• Niet inzetbaar voor steen, glas en nagels/ spijkers</li> </ul> |
|--|--|--|--|

| Producteigenschappen |        |        |          |    |                |          |               |          |   | Bestelinformatie |      |  |
|----------------------|--------|--------|----------|----|----------------|----------|---------------|----------|---|------------------|------|--|
| Ø D [mm]             | B [mm] | b [mm] | Ø d [mm] | Z  | Snijkwaliteit* | NL**     | Spaanhoek [°] | VE [St.] | V | Bestelnummer     |      |  |
| 160                  | 3,0    | 2,2    | 20       | 4  | ▲              | 2/6/32,5 | 8             | 1        | o | 58458790         |      |  |
| 180                  | 2,6    | 2,0    | 30       | 4  | ▲              | 2/6/32,5 | 8             | 1        | o | 58458799         |      |  |
| 190                  | 2,6    | 2,2    | 20       | 4  | ▲              | Fast-Fix | 8             | 1        | o | 58458800         |      |  |
| 190                  | 3,0    | 2,2    | 30       | 4  | ▲              | 2/7/42   | 8             | 1        | o | 58458791         |      |  |
| 216                  | 3,0    | 2,2    | 30       | 4  | ▲              | Combi3   | 8             | 1        | o | 58458792         |      |  |
| 230                  | 3,0    | 2,2    | 30       | 6  | ▲▲             | Combi3   | 8             | 1        | o | 58458793         |      |  |
| 250                  | 3,0    | 2,2    | 30       | 6  | ▲▲             | Combi3   | 8             | 1        | o | 58458794         |      |  |
| 260                  | 2,5    | 1,8    | 30       | 8  | ▲▲             | Combi3   | 8             | 1        | o | 58458797         |      |  |
| 305                  | 3,0    | 2,2    | 30       | 8  | ▲▲             | Combi3   | 5             | 1        | o | 58458795         | NEUW |  |
| 315                  | 3,0    | 2,2    | 30       | 10 | ▲▲             | Combi3   | 8             | 1        | o | 58458801         | NEUW |  |
| 350                  | 3,4    | 2,4    | 30       | 12 | ▲▲             | Combi3   | 8             | 1        | o | 58458802         | NEUW |  |
| 400                  | 3,4    | 2,4    | 30       | 15 | ▲▲▲            | Combi3   | 8             | 1        | o | 58458798         |      |  |

\* Snijkwaliteit ▲ Zeer grove snede, ▲▲ Grove snede, ▲▲▲ Fijne snede, ▲▲▲▲ Zeer fijne snede

\*\* Extra gaten: Combi1 komt overeen met 2/10/60 + 2/7/42 Combi2 komt overeen met 2/7/42 + 2/9/46 en 2/10/60 Combi3 = 2/10/60 + 2/9/46 + 2/9,5/46,5 + 2/7/42 Combi5 = 2/7/110 + 2/9/110 + 2/8,4/130 + 2/14/110 + 4/9/100 + 4/19/120 Combi7 = 2/9/110 + 2/10/80 + 2/11/85 + 2/11/115 + 2/11/148 + 2/14/100 + 2/14/125 + 2/19/120

Geschikte reduceerringen vindt u aan het einde van dit hoofdstuk

## DP HKS - nn-System DP flex Handcirkelzaagbladen (DP) - holle rugtand

Product



Tekening

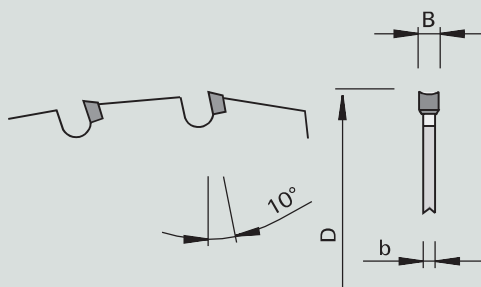

Machine



Toepassing



Uitvoering



Machine / gebruiksaanwijzing

- Handcirkelzaagbladen
- Afkortzagen
- Voor precisiesnedes in alle gangbare platen op basis van hout en latten
- Voor langs- en dwarsnedes in massief hout
- Te gebruiken voor diverse materialen zoals gevelplaten

Uitvoering

- Tandvorm: hollerugtand 'HR'
- Snijmateriaal: DP
- Speciale snijgeometrie
- Kleine spaanruimtes
- Stamblad gecoat

Voordelen

- Hoogste rendabiliteit en productiviteit door extreem lange standtijd
- Verminderde snijdruk door holleruggeometrie
- Coating beschermt tegen corrosie, hechting van vreemde materialen en vermindert de wrijving bij het stamblad

Informatie - Tip

- Reinig de nn-systeem DP flex cirkelzaagbladen regelmatig U profiteert van een langdurige, precieze snijkwaliteit en maximaliseert de standtijd van uw innovatieve zaagbladen aanzienlijk.

Producteigenschappen

Bestelinformatie

| Ø D [mm] | B [mm] | b [mm] | Ø d [mm] | Z  | Snijkwaliteit* | NL** | Spaanhoek [°] | VE [St.] | V | Bestelnummer |
|----------|--------|--------|----------|----|----------------|------|---------------|----------|---|--------------|
| 160      | 2,2    | 1,6    | 20       | 20 | ▲▲▲            |      | 10            | 1        |   | 58459771     |
| 160      | 2,2    | 1,8    | 20       | 30 | ▲▲▲            |      | 10            | 1        |   | 58459767     |
| 190      | 2,5    | 2,0    | 30       | 36 | ▲▲▲            |      | 10            | 1        | s | 58459768     |
| 216      | 2,5    | 2,0    | 30       | 40 | ▲▲▲            |      | 10            | 1        |   | 58459769     |
| 230      | 2,5    | 2,0    | 30       | 60 | ▲▲▲            |      | 10            | 1        | s | 58459770     |

\* Snijkwaliteit ▲ Zeer grove snede, ▲▲ Grove snede, ▲▲▲ Fijne snede, ▲▲▲▲ Zeer fijne snede





\*\* Extra gaten: Combi1 komt overeen met 2/10/60 + 2/7/42 Combi2 komt overeen met 2/7/42 + 2/9/46 en 2/10/60 Combi3 = 2/10/60 + 2/9/46 + 2/9.5/46.5 + 2/7/42 Combi5 = 2/7/110 + 2/9/110 + 2/8.4/130 + 2/14/110 + 4/9/100 + 4/19/120 Combi7 = 2/9/110 + 2/10/80 + 2/11/85 + 2/11/115 + 2/11/148 + 2/14/100 + 2/14/125 + 2/19/120

Geschikte reduceerringen vindt u aan het einde van dit hoofdstuk

**HW**

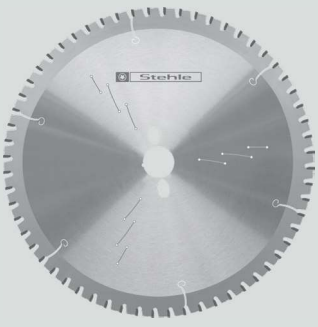
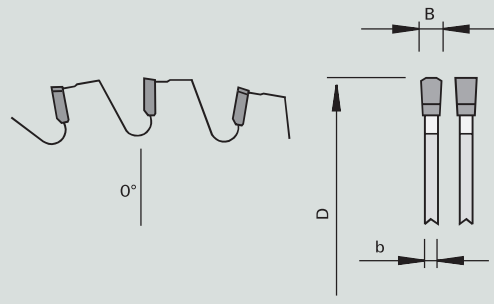
**Unisteel (HKS)**

**NE-afkortcirkelzaagbladen HW - spaanhoek neutraal trapezium-vlaktand**

|  |  |  |   |   |
|--|--|--|---|---|
| <p>Product</p>  | <p>Tekening</p>  | <p>Machine</p>  | <p>Toepassing</p>  | <p>Uitvoering</p>  |
|--|--|--|---|---|

|  |  |   |   |
|--|--|---|---|
| <p>Machine / gebruiksaanwijzing</p> <ul style="list-style-type: none"> <li>• Kap- en radiaal cirkelzagen</li> <li>• Voor zaagsneden in metalen en NE-metalen, (zink), lood, gietijzer, etc.</li> </ul> | <p>Uitvoering</p> <ul style="list-style-type: none"> <li>• Tandvorm: trapezium-vlaktand "TR-F"</li> <li>• Tandbezetting: HW TCm13</li> </ul> | <p>Voordelen</p> <ul style="list-style-type: none"> <li>• Verbeterde snijkwaliteit door speciale tandgeometrie</li> </ul> | <p>Informatie - Tip</p> <ul style="list-style-type: none"> <li>• Voor plaatmaterialen en kunststoffen zie ZWS en Parat-negatief (HKS)</li> <li>• Kleinere standtijd bij edelstalen</li> </ul> |
|--|--|---|---|

| Producteigenschappen |        |        |          |    |                |          |               | Bestelinformatie |   |              |  |
|----------------------|--------|--------|----------|----|----------------|----------|---------------|------------------|---|--------------|--|
| Ø D [mm]             | B [mm] | b [mm] | Ø d [mm] | Z  | Snijkwaliteit* | NL**     | Spaanhoek [°] | VE [St.]         | V | Bestelnummer |  |
| 150                  | 2,2    | 1,6    | 20       | 30 | ▲▲             | 2/6/32,5 | 0             | ●●●●             | 1 | 58116502     |  |
| 160                  | 2,2    | 1,6    | 20       | 30 | ▲▲             | 2/6/32,5 | 0             | ●●●●             | 1 | 58116504     |  |
| 180                  | 2,2    | 1,6    | 20       | 36 | ▲▲             | 2/6/32,5 | 0             | ●●●●             | 1 | 58116507     |  |
| 180                  | 2,2    | 1,6    | 30       | 36 | ▲▲             | 2/7/42   | 0             | ●●●●             | 1 | 58116508     |  |
| 190                  | 2,4    | 1,8    | 20       | 38 | ▲▲             | 2/6/32,5 | 0             | ●●●●             | 1 | 58116509     |  |
| 190                  | 2,4    | 1,8    | 30       | 38 | ▲▲             | Combi3   | 0             | ●●●●             | 1 | 58116510     |  |
| 200                  | 2,4    | 1,8    | 30       | 40 | ▲▲             | 2/7/42   | 0             | ●●●●             | 1 | 58116511     |  |
| 210                  | 2,4    | 1,8    | 30       | 40 | ▲▲             | 2/7/42   | 0             | ●●●●             | 1 | 58116512     |  |
| 216                  | 2,4    | 1,8    | 30       | 40 | ▲▲             | 2/7/42   | 0             | ●●●●             | 1 | 58116520     |  |
| 230                  | 2,4    | 1,8    | 30       | 44 | ▲▲             | 2/7/42   | 0             | ●●●●             | 1 | 58116514     |  |
| 235                  | 2,4    | 1,8    | 30       | 44 | ▲▲             | 2/7/42   | 0             | ●●●●             | 1 | 58116521     |  |
| 240                  | 2,4    | 1,8    | 30       | 44 | ▲▲             | Combi3   | 0             | ●●●●             | 1 | 58116515     |  |

\* Snijkwaliteit ▲ Zeer grove snede, ▲▲ Grove snede, ▲▲▲ Fijne snede, ▲▲▲▲ Zeer fijne snede

\*\* Extra gaten: Combi1 komt overeen met 2/10/60 + 2/7/42 Combi2 komt overeen met 2/7/42 + 2/9/46 en 2/10/60 Combi3 = 2/10/60 + 2/9/46 + 2/9.5/46.5 + 2/7/42 Combi5 = 2/7/110 + 2/9/110 + 2/8.4/130 + 2/14/110 + 4/9/100 + 4/19/120 Combi7 = 2/9/110 + 2/10/80 + 2/11/85 + 2/11/115 + 2/11/148 + 2/14/100 + 2/14/125 + 2/19/120

Geschikte reduceerringen vindt u aan het einde van dit hoofdstuk



# HW Parat - negatief (HKS)

## Universeel cirkelzaagblad - negatieve spaanhoek trapezium-vlaktand

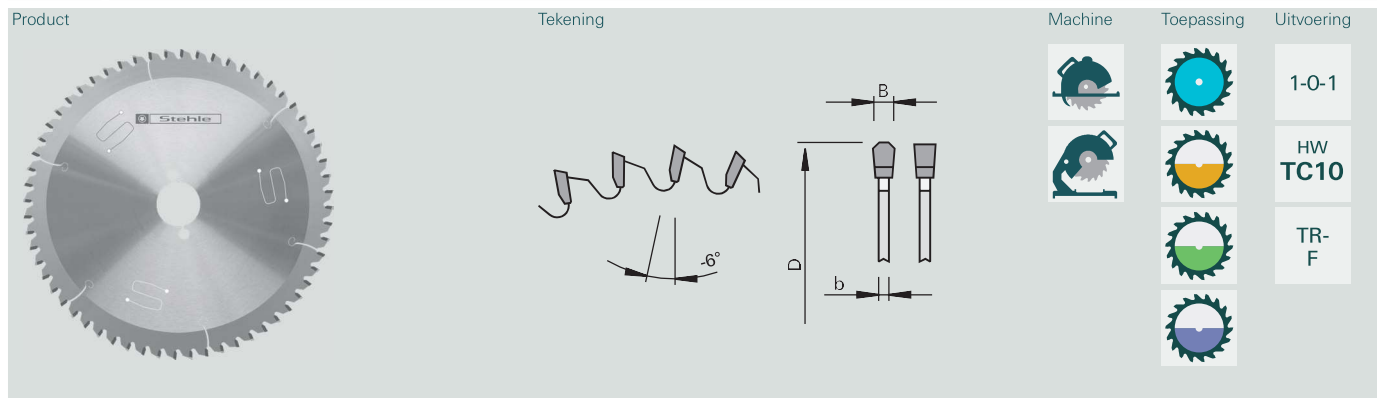

|  |   |   |                                |
|--|---|---|--------------------------------|
| <p><b>Machine / gebruiksaanwijzing</b></p> <ul style="list-style-type: none"> <li>• Kap- en radiaal cirkelzagen</li> <li>• Handcirkelzagen</li> <li>• Voor vele toepassingsmogelijkheden en materialen (NE-metalen, volkern, kunststoffen(profielen) en volkern-materialen/ trespa)</li> </ul> | <p><b>Uitvoering</b></p> <ul style="list-style-type: none"> <li>• Negatieve spaanhoek</li> <li>• Tandvorm: trapezium-vlaktand "TR-F"</li> <li>• Tandbezetting: HW TC10</li> </ul> | <p><b>Voordelen</b></p> <ul style="list-style-type: none"> <li>• Negatieve spaanhoek voor zuivere en mooie snijkwaliteit</li> </ul> | <p><b>Informatie - Tip</b></p> |
|--|---|---|--------------------------------|

| Producteigenschappen |        |        |          |    |                |          |               | Bestelinformatie |   |              |  |
|----------------------|--------|--------|----------|----|----------------|----------|---------------|------------------|---|--------------|--|
| Ø D [mm]             | B [mm] | b [mm] | Ø d [mm] | Z  | Snijkwaliteit* | NL**     | Spaanhoek [°] | VE [St.]         | V | Bestelnummer |  |
| 130                  | 2,8    | 2,2    | 20       | 36 | ▲▲             |          | -6            | 1                | o | 58115027     |  |
| 150                  | 2,8    | 2,2    | 20       | 42 | ▲▲             | 2/6/32,5 | -6            | 1                |   | 58115002     |  |
| 160                  | 2,2    | 1,6    | 20       | 42 | ▲▲             | 2/6/32,5 | -6            | 1                |   | 58115004     |  |
| 160                  | 2,2    | 1,6    | 20       | 56 | ▲▲▲            | 2/6/32,5 | -6            | 1                |   | 58115042     |  |
| 160                  | 2,8    | 2,2    | 30       | 42 | ▲▲             | 2/7/42   | -6            | 1                |   | 58115026     |  |
| 165                  | 2,4    | 1,6    | 20       | 48 | ▲▲             | 2/6/32,5 | -6            | 1                | o | 58115044     |  |
| 180                  | 2,8    | 2,2    | 20       | 48 | ▲▲             | 2/6/32,5 | -6            | 1                |   | 58115007     |  |
| 180                  | 2,8    | 2,2    | 30       | 48 | ▲▲             | 2/7/42   | -6            | 1                |   | 58115008     |  |
| 190                  | 2,8    | 2,2    | 20       | 54 | ▲▲             | 2/6/32,5 | -6            | 1                |   | 58115009     |  |
| 190                  | 2,6    | 2,0    | 20FX     | 58 | ▲▲             | Fast-Fix | -6            | 1                | o | 58115033     |  |
| 190                  | 2,8    | 2,2    | 30       | 54 | ▲▲             | 2/7/42   | -6            | 1                |   | 58115010     |  |
| 200                  | 2,8    | 2,2    | 30       | 54 | ▲▲             | 2/7/42   | -6            | 1                |   | 58115011     |  |
| 210                  | 2,8    | 2,2    | 30       | 54 | ▲▲             | 2/7/42   | -6            | 1                |   | 58115012     |  |
| 216                  | 2,8    | 2,2    | 30       | 60 | ▲▲             | 2/7/42   | -6            | 1                |   | 58115024     |  |
| 216                  | 2,8    | 2,2    | 30       | 80 | ▲▲▲            | 2/7/42   | -6            | 1                |   | 58115034     |  |
| 220                  | 2,8    | 2,2    | 30       | 54 | ▲▲             | 2/7/42   | -6            | 1                |   | 58115021     |  |
| 225                  | 2,8    | 2,2    | 30       | 60 | ▲▲             | Combi3   | -6            | 1                |   | 58115039     |  |
| 230                  | 2,8    | 2,2    | 30       | 64 | ▲▲             | 2/7/42   | -6            | 1                |   | 58115014     |  |



\* Snijkwaliteit ▲ Zeer grove snede, ▲▲ Grove snede, ▲▲▲ Fijne snede, ▲▲▲▲ Zeer fijne snede

\*\* Extra gaten: Combi1 komt overeen met 2/10/60 + 2/7/42 Combi2 komt overeen met 2/7/42 + 2/9/46 en 2/10/60 Combi3 = 2/10/60 + 2/9/46 + 2/9.5/46.5 + 2/7/42 Combi5 = 2/7/110 + 2/9/110 + 2/8.4/130 + 2/14/110 + 4/9/100 + 4/19/120 Combi7 = 2/9/110 + 2/10/80 + 2/11/85 + 2/11/115 + 2/11/148 + 2/14/100 + 2/14/125 + 2/19/120





Geschikte reduceerringen vindt u aan het einde van dit hoofdstuk

# HW Handcirkelzaagbladen - Set HW

Set = driedelig in een houten koffertje

|   |          |   |   |  |
|---|----------|---|---|--|
| Product   | Tekening | Machine   | Toepassing  | Uitvoering                               |
|  |          |  |  | 2-0-6<br>HW<br><b>TC10</b><br>TR-F<br>WS |



|  |   |           |                  |
|--|---|-----------|------------------|
| Machine / gebruiksaanwijzing   | Uitvoering  | Voordelen | Informatie - Tip |
| <ul style="list-style-type: none"> <li>• Handcirkelzagen</li> <li>• Kap- en radiaal cirkelzagen</li> <li>• Voor schulpen en afkorten van massief hout</li> </ul> | <ul style="list-style-type: none"> <li>• Tandvorm: wisseltand 'WS'</li> <li>• tandvorm: trapezium-vlaktand 'TR-F'</li> <li>• Snijmateriaal HW TC10</li> </ul> |           |                  |

| Producteigenschappen         |        |        |          |    |          |      |          | Bestelinformatie |   |              |          |
|------------------------------|--------|--------|----------|----|----------|------|----------|------------------|---|--------------|----------|
| Afmeting [mm]                |        |        |          |    |          |      |          | VE [St.]         | V   | Bestelnummer |          |
| Handcirkelzaagbladen - Set 1 |        |        |          |    |          |      |          | 160x20           |    | 1            | 50111160 |
| Ø D [mm]                     | B [mm] | b [mm] | Ø d [mm] | Z  | Tandvorm | NL   | VE [St.] | V                | Bestelnummer  |              |          |
| HKS - Massief                | 160    | 2,2    | 1,6      | 20 | 24       | WS   | 2/6/32,5 | 1                | 50110054  |              |          |
| HKS - Board                  | 160    | 2,2    | 1,6      | 20 | 48       | WS   | 2/6/32,5 | 1                | 50110056  |              |          |
| Parat - negatief             | 160    | 2,2    | 1,6      | 20 | 42       | TR-F | 2/6/32,5 | 1                | 58115004  |              |          |
| Afmeting [mm]                |        |        |          |    |          |      |          | VE [St.]         | V   | Bestelnummer |          |
| Handcirkelzaagbladen - Set 2 |        |        |          |    |          |      |          | 160x20           |  | 1            | 50111163 |
| Ø D [mm]                     | B [mm] | b [mm] | Ø d [mm] | Z  | Tandvorm | NL   | VE [St.] | V                | Bestelnummer  |              |          |
| HKS - Massief                | 160    | 2,2    | 1,6      | 20 | 24       | WS   | 2/6/32,5 | 1                | 50110054  |              |          |
| HKS - Board                  | 160    | 2,2    | 1,6      | 20 | 36       | WS   | 2/6/32,5 | 1                | 50110055  |              |          |
| HKS - Board                  | 160    | 2,2    | 1,6      | 20 | 48       | WS   | 2/6/32,5 | 1                | 50110056  |              |          |
| Afmeting [mm]                |        |        |          |    |          |      |          | VE [St.]         | V   | Bestelnummer |          |
| Handcirkelzaagbladen - Set 3 |        |        |          |    |          |      |          | 190x30           |  | 1            | 50111193 |
| Ø D [mm]                     | B [mm] | b [mm] | Ø d [mm] | Z  | Tandvorm | NL   | VE [St.] | V                | Bestelnummer  |              |          |
| HKS - Massief                | 190    | 2,6    | 1,6      | 30 | 24       | WS   | 2/7/42   | 1                | 50110155  |              |          |
| HKS - Board                  | 190    | 2,6    | 1,6      | 30 | 30       | WS   | 2/7/42   | 1                | 50110089  |              |          |
| HKS - Board                  | 190    | 2,6    | 1,6      | 30 | 48       | WS   | 2/7/42   | 1                | 50110090  |              |          |
| Afmeting [mm]                |        |        |          |    |          |      |          | VE [St.]         | V   | Bestelnummer |          |
| Handcirkelzaagbladen - Set 4 |        |        |          |    |          |      |          | 190x30           |  | 1            | 50111190 |
| Ø D [mm]                     | B [mm] | b [mm] | Ø d [mm] | Z  | Tandvorm | NL   | VE [St.] | V                | Bestelnummer  |              |          |
| HKS - Massief                | 190    | 2,6    | 1,6      | 30 | 24       | WS   | 2/7/42   | 1                | 50110155  |              |          |
| HKS - Board                  | 190    | 2,6    | 1,6      | 30 | 48       | WS   | 2/7/42   | 1                | 50110090  |              |          |
| Parat - negatief             | 190    | 2,8    | 2,2      | 30 | 54       | TR-F | 2/7/42   | 1                | 58115010  |              |          |

\* Snijkwaliteit ▲ Zeer grove snede, ▲▲ Grove snede, ▲▲▲ Fijne snede, ▲▲▲▲ Zeer fijne snede

\*\* Extra gaten: Combi1 komt overeen met 2/10/60 + 2/7/42 Combi2 komt overeen met 2/7/42 + 2/9/46 en 2/10/60 Combi3 = 2/10/60 + 2/9/46 + 2/9,5/46,5 + 2/7/42 Combi5 = 2/7/110 + 2/9/110 + 2/8,4/130 + 2/14/110 + 4/9/100 + 4/19/120 Combi7 = 2/9/110 + 2/10/80 + 2/11/85 + 2/11/115 + 2/11/148 + 2/14/100 + 2/14/125 + 2/19/120

Geschikte reduceerringen vindt u aan het einde van dit hoofdstuk

| Afmeting [mm]                |        |        |          |    |          |      |                                     | VE [St.]  | V        |          |
|------------------------------|--------|--------|----------|----|----------|------|-------------------------------------|---|----------|----------|
| Handcirkelzaagbladen - Set 5 |        | 216x30 |          |    |          |      |                                     |  | 1        | 50111216 |
| Ø D [mm]                     | B [mm] | b [mm] | Ø d [mm] | Z  | Tandvorm | NL   | VE [St.]                            | V   |          |          |
| Parat - negatief             | 216    | 2,8    | 2,2      | 30 | 60       | TR-F | 2/7/42                              | 1   | 58115024 |          |
| K + G negatief               | 216    | 2,8    | 1,8      | 30 | 48       | WS   | 2/7/42                              | 1   | 58110181 |          |
| K + G negatief               | 216    | 2,8    | 1,8      | 30 | 24       | WS   | 2/7/42                              | 1   | 58110180 |          |
| Afmeting [mm]                |        |        |          |    |          |      |                                     | VE [St.]  | V        |          |
| Handcirkelzaagbladen - Set 6 |        | 235x30 |          |    |          |      |                                     |  | 1        | 50111235 |
| Ø D [mm]                     | B [mm] | b [mm] | Ø d [mm] | Z  | Tandvorm | NL   | VE [St.]                            | V   |          |          |
| ZQW                          | 235    | 2,8    | 1,8      | 30 | 24       | WS   | 2/7/42                              | 1   | 50110170 |          |
| ZWS                          | 235    | 2,8    | 1,8      | 30 | 48       | WS   | 2/7/42                              | 1   | 58110121 |          |
| NE-negatief                  | 235    | 2,8    | 2,2      | 30 | 64       | TR-F | 2/7/42                              | 1   | 58115018 |          |
| Afmeting [mm]                |        |        |          |    |          |      |                                     | VE [St.]  | V        |          |
| Handcirkelzaagbladen - Set 7 |        | 250x30 |          |    |          |      |                                     |  | 1        | 50111250 |
| Ø D [mm]                     | B [mm] | b [mm] | Ø d [mm] | Z  | Tandvorm | NL   | VE [St.]                            | V   |          |          |
| ZQW                          | 250    | 3,2    | 2,2      | 30 | 24       | WS   | 2/7/42 +<br>2/9,5/46,5<br>+ 2/10/60 | 1   | 58120060 |          |
| ZWS                          | 250    | 3,2    | 2,2      | 30 | 40       | WS   | 2/7/42 +<br>2/9,5/46,5<br>+ 2/10/60 | 1   | 58100018 |          |
| NE-negatief                  | 250    | 3,2    | 2,5      | 30 | 80       | TR-F | 2/7/42 +<br>2/9,5/46,5<br>+ 2/10/60 | 1   | 58808203 |          |

\* **Snijkwaliteit** ▲ Zeer grove snede, ▲▲ Grove snede, ▲▲▲ Fijne snede, ▲▲▲▲ Zeer fijne snede





\*\* **Extra gaten: Combi1** komt overeen met 2/10/60 + 2/7/42 **Combi2** komt overeen met 2/7/42 + 2/9/46 en 2/10/60 **Combi3** = 2/10/60 + 2/9/46 + 2/9,5/46,5 + 2/7/42 **Combi5** = 2/7/110 + 2/9/110 + 2/8,4/130 + 2/14/110 + 4/9/100 + 4/19/120 **Combi7** = 2/9/110 + 2/10/80 + 2/11/85 + 2/11/115 + 2/11/148 + 2/14/100 + 2/14/125 + 2/19/120

Geschikte **reduceerringen** vindt u aan het einde van dit hoofdstuk

**HW**

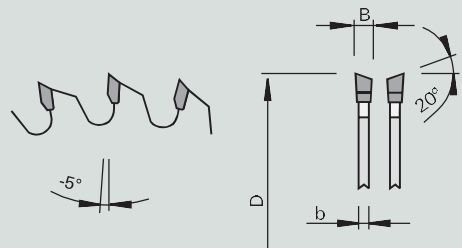
**K + G negatief**

Kap- en radiaal cirkelzaagbladen HW - wisseltand

|  |  |  |  |
|--|--|--|--|
| <p>Product</p>  | <p>Tekening</p>  | <p>Machine</p>  | <p>Toepassing</p>  <p>Uitvoering</p> <p>2-0-6</p>  <p>HW<br/><b>TC06</b></p> <p>WS</p> |
|--|--|--|--|

|   |   |  |                         |
|---|---|--|-------------------------|
| <p>Machine / gebruiksaanwijzing</p> <ul style="list-style-type: none"> <li>• Kap- en radiaal cirkelzagen</li> <li>• Voor dwarsneden in massief hout en plaatmaterialen</li> </ul> | <p>Uitvoering</p> <ul style="list-style-type: none"> <li>• Tandvorm: wisseltand "WS"</li> <li>• Tandbezetting: HW TC06</li> </ul> | <p>Voordelen</p> <ul style="list-style-type: none"> <li>• Negatieve spaanhoek voor zuivere en mooie snijkwaliteit</li> </ul> | <p>Informatie - Tip</p> |
|---|---|--|-------------------------|

| Producteigenschappen |        |        |          |    |                | Bestelinformatie |               |          |   |              |
|----------------------|--------|--------|----------|----|----------------|------------------|---------------|----------|---|--------------|
| Ø D [mm]             | B [mm] | b [mm] | Ø d [mm] | Z  | Snijkwaliteit* | NL**             | Spaanhoek [°] | VE [St.] | V | Bestelnummer |
| 210                  | 2,8    | 1,8    | 30       | 48 | ▲▲             | 2/7/42           | -5            | 1        |   | 58110194     |
| 216                  | 2,8    | 1,8    | 30       | 24 | ▲              | 2/7/42           | -5            | 1        |   | 58110180     |
| 216                  | 2,8    | 1,8    | 30       | 48 | ▲▲             | 2/7/42           | -5            | 1        |   | 58110181     |
| 216                  | 2,8    | 1,8    | 30       | 60 | ▲▲▲            | 2/7/42           | -5            | 1        |   | 58110192     |
| 254                  | 3,2    | 2,2    | 30       | 24 | ▲▲             | Combi3           | -5            | 1        |   | 58118119     |
| 254                  | 3,2    | 2,2    | 30       | 40 | ▲▲             | Combi3           | -5            | 1        |   | 58100218     |
| 254                  | 3,2    | 2,2    | 30       | 60 | ▲▲▲            | Combi3           | -5            | 1        |   | 58100231     |
| 254                  | 3,2    | 2,2    | 30       | 80 | ▲▲▲            | Combi3           | -5            | 1        |   | 58110139     |
| 260                  | 2,5    | 1,8    | 30       | 60 | ▲▲             | Combi3           | -5            | 1        |   | 58100233     |
| 260                  | 2,5    | 1,8    | 30       | 80 | ▲▲▲            | Combi3           | -5            | 1        |   | 58100234     |
| 300                  | 3,2    | 2,2    | 40       | 72 | ▲▲▲            | 4/12/64 + 2/9/55 | -5            | 1        |   | 58100237     |
| 305                  | 3,2    | 2,2    | 30       | 60 | ▲▲             | Combi3           | -5            | 1        |   | 58110281     |
| 305                  | 3,2    | 2,2    | 30       | 32 | ▲              | Combi3           | -5            | 1        |   | 58110270     |
| 305                  | 3,2    | 2,2    | 30       | 96 | ▲▲▲            | Combi3           | -5            | 1        |   | 58110272     |
| 315                  | 3,2    | 2,2    | 30       | 84 | ▲▲▲▲           | Combi3           | -5            | 1        | o | 58110274     |
| 350                  | 3,2    | 2,2    | 40       | 72 | ▲▲             | 4/12/64 + 2/9/55 | -5            | 1        |   | 58110273     |
| 355                  | 3,5    | 2,5    | 30       | 96 | ▲▲▲            | Combi3           | -5            | 1        |   | 58110143     |
| 420                  | 3,5    | 2,5    | 40       | 84 | ▲▲             | 4/12/64 + 2/9/55 | -5            | 1        |   | 58110144     |
| 420                  | 4,4    | 2,8    | 40       | 54 | ▲▲             | 4/12/64 + 2/9/55 | -5            | 1        |   | 58110145     |

\* Snijkwaliteit ▲ Zeer grove snede, ▲▲ Grove snede, ▲▲▲ Fijne snede, ▲▲▲▲ Zeer fijne snede

\*\* Extra gaten: Combi1 komt overeen met 2/10/60 + 2/7/42 Combi2 komt overeen met 2/7/42 + 2/9/46 en 2/10/60 Combi3 = 2/10/60 + 2/9/46 + 2/9,5/46,5 + 2/7/42 Combi5 = 2/7/110 + 2/9/110 + 2/8,4/130 + 2/14/110 + 4/9/100 + 4/19/120 Combi7 = 2/9/110 + 2/10/80 + 2/11/85 + 2/11/115 + 2/11/148 + 2/14/100 + 2/14/125 + 2/19/120

Geschikte reduceerringen vindt u aan het einde van dit hoofdstuk

**HW**

**BKS (NAIL)**

Bouw/ Nail zaagbladen HW - vlakland met tweezijdige fase

Product

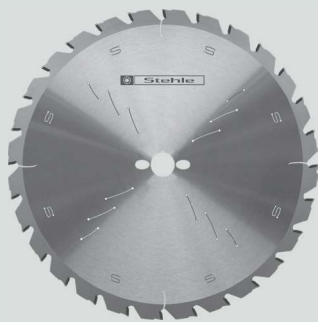

Tekening

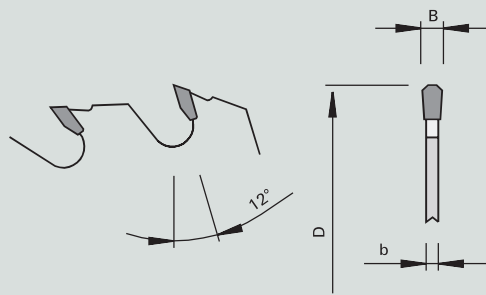

Machine



Toepassing



Uitvoering

2-0-6

HW  
TC25

F-  
FA

Machine / gebruiksaanwijzing

- Tafelzaagmachines (bouwplaats)
- Handcirkelzaagbladen
- Kap- en radiaalcirkelzagen
- Voor zaagsneden in massief hout en houtbevattende plaatmaterialen

Uitvoering

- Tandvorm: vlakland met tweezijdige fase "F-FA"
- Tandbezetting: HW TC25

Voordelen

- Voor probleemloos doorzagen van hout met vastzittende nagels, spijkers of nieten

Informatie - Tip

- Asgat vergroten tegen meerprijs mogelijk tot Ø 50 mm
- bij Kap- en radiaalcirkelzagen goed gespannen werkstuk in acht nemen

Producteigenschappen

Bestelinformatie

| Ø D [mm] | B [mm] | b [mm] | Ø d [mm] | Z  | Snijkwaliteit* | NL**   | Spaanhoek [°] |     | VE [St.] | V | Bestelnummer |
|----------|--------|--------|----------|----|----------------|--------|---------------|-----|----------|---|--------------|
| 190      | 3,0    | 2,0    | 30       | 14 | ▲              | 2/7/42 | 12            | ●●● | 1        |   | 58112011     |
| 210      | 3,2    | 2,2    | 30       | 14 | ▲              | 2/7/42 | 12            | ●●● | 1        | o | 50112013     |
| 235      | 2,8    | 1,8    | 30       | 16 | ▲              | Combi3 | 12            | ●●● | 1        |   | 58112015     |
| 250      | 3,2    | 2,2    | 30       | 16 | ▲              | Combi3 | 12            | ●●● | 1        |   | 58120220     |
| 300      | 3,2    | 2,2    | 30       | 20 | ▲              | Combi3 | 12            | ●●● | 1        |   | 58120041     |
| 315      | 3,2    | 2,2    | 30       | 20 | ▲              | Combi3 | 12            | ●●● | 1        |   | 58120046     |
| 350      | 3,5    | 2,5    | 30       | 24 | ▲              | Combi3 | 12            | ●●● | 1        |   | 58120042     |
| 400      | 3,5    | 2,5    | 30       | 28 | ▲              | Combi3 | 12            | ●●● | 1        |   | 58120043     |
| 450      | 3,8    | 2,8    | 30       | 30 | ▲              | Combi3 | 12            | ●●● | 1        |   | 58120044     |
| 500      | 3,8    | 2,8    | 30       | 34 | ▲              | Combi3 | 12            | ●●● | 1        |   | 58120045     |
| 600      | 4,4    | 3,2    | 30       | 36 | ▲              | Combi3 | 12            | ●●● | 1        |   | 58120227     |
| 700      | 4,6    | 3,2    | 30       | 42 | ▲              | Combi3 | 12            | ●●● | 1        |   | 58120228     |

\* Snijkwaliteit ▲ Zeer grove snede, ▲▲ Grove snede, ▲▲▲ Fijne snede, ▲▲▲▲ Zeer fijne snede



\*\* Extra gaten: Combi1 komt overeen met 2/10/60 + 2/7/42 Combi2 komt overeen met 2/7/42 + 2/9/46 en 2/10/60 Combi3 = 2/10/60 + 2/9/46 + 2/9.5/46.5 + 2/7/42 Combi5 = 2/7/110 + 2/9/110 + 2/8.4/130 + 2/14/110 + 4/9/100 + 4/19/120 Combi7 = 2/9/110 + 2/10/80 + 2/11/85 + 2/11/115 + 2/11/148 + 2/14/100 + 2/14/125 + 2/19/120

Geschikte reduceerringen vindt u aan het einde van dit hoofdstuk

HW

ZFL

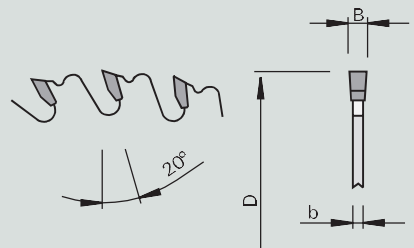
Schulp- en afkortzaagblad HW vlakland

|   |  |   |   |                                 |
|---|--|---|---|---------------------------------|
| Product   | Tekening   | Machine   | Toepassing  | Uitvoering                      |
|  |  |  |  | 2-0-6<br>HW<br><b>TC10</b><br>F |

|  |  |   |  |
|--|--|---|--|
| Machine / gebruiksaanwijzing   | Uitvoering   | Voordelen   | Informatie - Tip   |
| <ul style="list-style-type: none"> <li>Tafelcirkelzagen</li> <li>Speciale machines</li> <li>Voor zaagsneden in massief hout</li> <li>Bijzonder geschikt voor hout met noesten</li> </ul> | <ul style="list-style-type: none"> <li>Tandvorm: vlakland "F"</li> <li>Tandbezetting: HW TC10</li> </ul> | <ul style="list-style-type: none"> <li>Geen materiaaluitbreuk door spaanbegrenzing van de tanden</li> </ul> | <ul style="list-style-type: none"> <li>Asgat vergroten tegen meerprijs mogelijk tot Ø 50 mm</li> </ul> |

| Producteigenschappen |        |        |          |    |                |        | Bestelinformatie |          |   |              |
|----------------------|--------|--------|----------|----|----------------|--------|------------------|----------|---|--------------|
| Ø D [mm]             | B [mm] | b [mm] | Ø d [mm] | Z  | Snijkwaliteit* | NL**   | Spaanhoek [°]    | VE [St.] | V | Bestelnummer |
| 250                  | 3,2    | 2,2    | 30       | 18 | ▲              | Combi3 | 20               | 1        |   | 58104050     |
| 270                  | 3,0    | 2,0    | 30       | 18 | ▲              | Combi3 | 20               | 1        | o | 58114170     |
| 315                  | 3,2    | 2,2    | 30       | 14 | ▲              | Combi3 | 20               | 1        |   | 58104055     |
| 350                  | 3,5    | 2,5    | 30       | 16 | ▲              | Combi3 | 20               | 1        |   | 58104015     |
| 350                  | 3,5    | 2,5    | 30       | 24 | ▲              | Combi3 | 20               | 1        |   | 58104041     |
| 400                  | 3,5    | 2,5    | 30       | 18 | ▲              | Combi3 | 20               | 1        |   | 58104021     |
| 450                  | 3,8    | 2,8    | 30       | 32 | ▲              | Combi3 | 20               | 1        |   | 58104051     |
| 500                  | 3,8    | 2,8    | 30       | 36 | ▲              | Combi3 | 20               | 1        |   | 58104052     |
| 550                  | 4,6    | 3,2    | 30       | 32 | ▲              | Combi3 | 20               | 1        |   | 58104054     |
| 600                  | 4,2    | 3,2    | 30       | 40 | ▲              | Combi3 | 20               | 1        |   | 58104048     |
| 700                  | 4,2    | 3,2    | 30       | 46 | ▲              | Combi3 | 20               | 1        |   | 58104049     |
| 700                  | 6,0    | 4,5    | 30       | 42 | ▲              | AMR    | 20               | 1        |   | 58104053     |

\* Snijkwaliteit ▲ Zeer grove snede, ▲▲ Grove snede, ▲▲▲ Fijne snede, ▲▲▲▲ Zeer fijne snede

\*\* Extra gaten: Combi1 komt overeen met 2/10/60 + 2/7/42 Combi2 komt overeen met 2/7/42 + 2/9/46 en 2/10/60 Combi3 = 2/10/60 + 2/9/46 + 2/9.5/46.5 + 2/7/42 Combi5 = 2/7/110 + 2/9/110 + 2/8.4/130 + 2/14/110 + 4/9/100 + 4/19/120 Combi7 = 2/9/110 + 2/10/80 + 2/11/85 + 2/11/115 + 2/11/148 + 2/14/100 + 2/14/125 + 2/19/120

Geschikte reduceerringen vindt u aan het einde van dit hoofdstuk

**HW** **ZWZ**  
Schulp- en afkortaagblad HW wisseltand

Product



Tekening

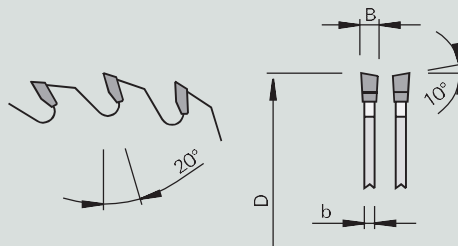

Machine



Toepassing



Uitvoering

2-0-6  
HW  
**TC20**  
WS

Machine / gebruiksaanwijzing

- Tafelcirkelzagen
- Speciale machines
- Voor schulpen in zacht massief hout
- voor het doorzagen, op lengte maken en in verstek zagen van balken, lijmverbindingen en kunststofplaten

Uitvoering

- Tandvorm: wisseltand 'WS'
- Snijmateriaal HW TC20

Voordelen

- Speciaal HW-Kwaliteit voor naaldhout
- Extreme tandoverstand voor beter functioneren van het zaagblad

Informatie - Tip

- Asgat vergroten tegen meerprijs mogelijk tot Ø 50 mm

Producteigenschappen

| Ø D [mm] | B [mm] | b [mm] | Ø d [mm] | Z  | Snijkwaliteit* | NL**   | Spaanhoek [°] | VE [St.] | V | Bestelnummer         |
|----------|--------|--------|----------|----|----------------|--------|---------------|----------|---|----------------------|
| 400      | 4,4    | 2,8    | 30       | 28 | ▲              | Combi3 | 20            | 1        |   | 58100183 <b>NEUW</b> |

\* Snijkwaliteit ▲ Zeer grove snede, ▲▲ Grove snede, ▲▲▲ Fijne snede, ▲▲▲▲ Zeer fijne snede



\*\* Extra gaten: Combi1 komt overeen met 2/10/60 + 2/7/42 Combi2 komt overeen met 2/7/42 + 2/9/46 en 2/10/60 Combi3 = 2/10/60 + 2/9/46 + 2/9.5/46.5 + 2/7/42 Combi5 = 2/7/110 + 2/9/110 + 2/8.4/130 + 2/14/110 + 4/9/100 + 4/19/120 Combi7 = 2/9/110 + 2/10/80 + 2/11/85 + 2/11/115 + 2/11/148 + 2/14/100 + 2/14/125 + 2/19/120

Geschikte reduceerringen vindt u aan het einde van dit hoofdstuk

HW

ZW

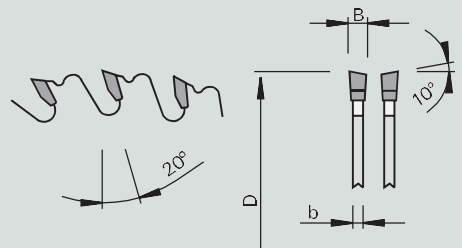
Schulp- en afkortzaagblad HW wisseltand

|   |  |   |   |                                  |
|---|--|---|---|----------------------------------|
| Product   | Tekening   | Machine   | Toepassing  | Uitvoering                       |
|  |  |  |  | 2-0-6<br>HW<br><b>TC10</b><br>WS |

|  |   |  |  |
|--|---|--|--|
| Machine / gebruiksaanwijzing   | Uitvoering  | Voordelen  | Informatie - Tip   |
| <ul style="list-style-type: none"> <li>Tafelcirkelzagen</li> <li>Speciale machines</li> <li>Voor zaagsneden in massief hout</li> <li>Bijzonder geschikt voor hout met noesten</li> </ul> | <ul style="list-style-type: none"> <li>Tandvorm: wisseltand "WS"</li> <li>Tandbezetting: HW TC10</li> </ul> | <ul style="list-style-type: none"> <li>Geen materiaalluitbreuk door spaanbegrenzing van de tanden</li> </ul> | <ul style="list-style-type: none"> <li>Asgat vergroten tegen meerprijs mogelijk tot Ø 50 mm</li> </ul> |

| Producteigenschappen |        |        |          |    |                |        | Bestelinformatie |  |          |   |              |
|----------------------|--------|--------|----------|----|----------------|--------|------------------|--|----------|---|--------------|
| Ø D [mm]             | B [mm] | b [mm] | Ø d [mm] | Z  | Snijkwaliteit* | NL**   | Spaanhoek [°]    |  | VE [St.] | V | Bestelnummer |
| 250                  | 3,2    | 2,2    | 30       | 24 | ▲              | Combi3 | 20               |  | 1        |   | 58102001     |
| 300                  | 3,2    | 2,2    | 30       | 28 | ▲▲             | Combi3 | 20               |  | 1        |   | 58102002     |
| 315                  | 3,2    | 2,2    | 30       | 28 | ▲▲             | Combi3 | 20               |  | 1        |   | 58102003     |
| 350                  | 3,5    | 2,5    | 30       | 32 | ▲▲             | Combi3 | 20               |  | 1        |   | 58101004     |
| 400                  | 3,5    | 2,5    | 30       | 36 | ▲▲             | Combi3 | 20               |  | 1        |   | 58101005     |
| 450                  | 4,2    | 2,8    | 30       | 20 | ▲▲             | Combi3 | 25               |  | 1        |   | 58101020     |
| 450                  | 3,8    | 2,8    | 30       | 40 | ▲▲             | Combi3 | 20               |  | 1        |   | 58101006     |
| 500                  | 3,8    | 2,8    | 30       | 44 | ▲▲             | Combi3 | 20               |  | 1        |   | 58102007     |
| 600                  | 4,2    | 3,2    | 30       | 54 | ▲▲             | Combi3 | 20               |  | 1        |   | 58101018     |
| 700                  | 4,2    | 3,2    | 30       | 60 | ▲▲             | Combi3 | 20               |  | 1        |   | 58101019     |

\* Snijkwaliteit ▲ Zeer grove snede, ▲▲ Grove snede, ▲▲▲ Fijne snede, ▲▲▲▲ Zeer fijne snede

\*\* Extra gaten: Combi1 komt overeen met 2/10/60 + 2/7/42 Combi2 komt overeen met 2/7/42 + 2/9/46 en 2/10/60 Combi3 = 2/10/60 + 2/9/46 + 2/9.5/46.5 + 2/7/42 Combi5 = 2/7/110 + 2/9/110 + 2/8.4/130 + 2/14/110 + 4/9/100 + 4/19/120 Combi7 = 2/9/110 + 2/10/80 + 2/11/85 + 2/11/115 + 2/11/148 + 2/14/100 + 2/14/125 + 2/19/120

Geschikte reduceerringen vindt u aan het einde van dit hoofdstuk



**HW** **ZQW**  
Schulp- en afkortzaagblad HW wisseltand

|         |          |         |            |                                   |
|---------|----------|---------|------------|-----------------------------------|
| Product | Tekening | Machine | Toepassing | Uitvoering                        |
|         |          |         |            | 2-0-6<br>HW TC06<br>HW TC10<br>WS |

|   |  |   |  |
|---|--|---|--|
| Machine / gebruiksaanwijzing  | Uitvoering   | Voordelen   | Informatie - Tip   |
| <ul style="list-style-type: none"> <li>Tafelcirkelzagen</li> <li>Speciale machines</li> <li>Voor formaatsneden in massief hout</li> </ul> | <ul style="list-style-type: none"> <li>Tandvorm: wisseltand 'WS'</li> <li>Snijmateriaal HW TC10/HW TC06</li> </ul> | <ul style="list-style-type: none"> <li>Optimale aanpassing aan de snijkwaliteit, aanvoersnelheid en materiaaldikte door verschillend aantal tanden</li> </ul> | <ul style="list-style-type: none"> <li>Asgat vergroten tegen meerprijs mogelijk tot Ø 50 mm</li> </ul> |

| Producteigenschappen |        |        |          |    |                |        |               | Bestelinformatie |          |   |              |
|----------------------|--------|--------|----------|----|----------------|--------|---------------|------------------|----------|---|--------------|
| Ø D [mm]             | B [mm] | b [mm] | Ø d [mm] | Z  | Snijkwaliteit* | NL**   | Spaanhoek [°] |                  | VE [St.] | V | Bestelnummer |
| 150                  | 3,2    | 2,2    | 30       | 24 | ▲              | 2/7/42 | 15            |                  | 1        |   | 58100096     |
| 180                  | 3,2    | 2,2    | 30       | 30 | ▲▲             | 2/7/42 | 15            |                  | 1        |   | 58100016     |
| 200                  | 3,2    | 2,2    | 30       | 34 | ▲▲             | 2/7/42 | 15            |                  | 1        |   | 58100017     |
| 235                  | 2,8    | 1,8    | 30       | 18 | ▲              | 2/7/42 | 20            |                  | 1        |   | 50110256     |
| 235                  | 2,8    | 1,8    | 30       | 24 | ▲▲             | 2/7/42 | 15            |                  | 1        |   | 50110170     |
| 235                  | 3,2    | 2,2    | 30       | 24 | ▲              | Combi3 | 10            |                  | 1        |   | 58100191     |
| 240                  | 2,8    | 1,8    | 30       | 24 | ▲▲             | 2/7/42 | 20            |                  | 1        |   | 50110174     |
| 250                  | 2,8    | 1,8    | 30       | 40 | ▲▲             | Combi3 | 15            |                  | 1        |   | 58120020     |
| 250                  | 3,2    | 2,2    | 30       | 24 | ▲▲             | Combi3 | 20            |                  | 1        |   | 58120060     |
| 250                  | 3,2    | 2,2    | 30       | 30 | ▲▲             | Combi3 | 20            |                  | 1        |   | 58120061     |
| 260                  | 3,2    | 2,2    | 30       | 32 | ▲▲             | Combi3 | 20            |                  | 1        |   | 58110185     |
| 270                  | 3,2    | 2,2    | 30       | 24 | ▲▲             | Combi3 | 20            |                  | 1        |   | 58110176     |
| 300                  | 3,2    | 2,2    | 30       | 24 | ▲              | Combi3 | 20            |                  | 1        |   | 58120002     |
| 300                  | 3,2    | 2,2    | 30       | 36 | ▲              | Combi3 | 20            |                  | 1        |   | 58120013     |
| 315                  | 3,2    | 2,2    | 30       | 28 | ▲              | Combi3 | 20            |                  | 1        |   | 58120062     |
| 315                  | 3,2    | 2,2    | 30       | 36 | ▲              | Combi3 | 20            |                  | 1        |   | 58100255     |
| 330                  | 3,2    | 2,2    | 30       | 24 | ▲              | Combi3 | 25            |                  | 1        |   | 58120018     |
| 335                  | 3,2    | 2,2    | 30       | 36 | ▲              | Combi3 | 20            |                  | 1        |   | 58120063     |
| 350                  | 3,5    | 2,5    | 30       | 24 | ▲              | Combi3 | 20            |                  | 1        |   | 58120005     |
| 350                  | 3,5    | 2,5    | 30       | 32 | ▲▲             | Combi3 | 20            |                  | 1        |   | 58100011     |
| 350                  | 3,5    | 2,5    | 30       | 36 | ▲              | Combi3 | 20            |                  | 1        |   | 58120014     |
| 350                  | 3,5    | 2,5    | 30       | 42 | ▲              | Combi3 | 20            |                  | 1        |   | 58120015     |
| 400                  | 3,5    | 2,5    | 30       | 28 | ▲              | Combi3 | 20            |                  | 1        |   | 58100005     |
| 400                  | 3,5    | 2,5    | 30       | 32 | ▲              | Combi3 | 20            |                  | 1        |   | 58120008     |
| 400                  | 3,5    | 2,5    | 30       | 36 | ▲▲             | Combi3 | 20            |                  | 1        |   | 58100012     |
| 400                  | 3,5    | 2,5    | 30       | 48 | ▲▲             | Combi3 | 20            |                  | 1        |   | 58120017     |
| 410                  | 3,8    | 2,8    | 30       | 28 | ▲              | Combi3 | 20            |                  | 1        |   | 58120019     |
| 450                  | 3,8    | 2,8    | 30       | 40 | ▲▲             | Combi3 | 20            |                  | 1        |   | 58100013     |
| 500                  | 3,8    | 2,8    | 30       | 44 | ▲▲             | Combi3 | 20            |                  | 1        |   | 58100014     |

\* Snijkwaliteit ▲ Zeer grove snede, ▲▲ Grove snede, ▲▲▲ Fijne snede, ▲▲▲▲ Zeer fijne snede

\*\* Extra gaten: Combi1 komt overeen met 2/10/60 + 2/7/42 Combi2 komt overeen met 2/7/42 + 2/9/46 en 2/10/60 Combi3 = 2/10/60 + 2/9/46 + 2/9.5/46.5 + 2/7/42 Combi5 = 2/7/110 + 2/9/110 + 2/8.4/130 + 2/14/110 + 4/9/100 + 4/19/120 Combi7 = 2/9/110 + 2/10/80 + 2/11/85 + 2/11/115 + 2/11/148 + 2/14/100 + 2/14/125 + 2/19/120

Geschikte reduceerringen vindt u aan het einde van dit hoofdstuk

HW

ZWS

Afkort en zuiversneden zaagblad HW - Wisseltand

|         |          |         |            |                           |
|---------|----------|---------|------------|---------------------------|
| Product | Tekening | Machine | Toepassing | Uitvoering                |
|         |          |         |            | 2-0-6<br>HW<br>TC06<br>WS |

|  |  |   |  |
|--|--|---|--|
| Machine / gebruiksaanwijzing   | Uitvoering   | Voordelen   | Informatie - Tip   |
| <ul style="list-style-type: none"> <li>Tafelcirkelzagen</li> <li>Speciale machines</li> <li>Voor formaatsneden in massief hout en plaatmaterialen</li> </ul> | <ul style="list-style-type: none"> <li>Tandvorm: wisseltand 'WS'</li> <li>Snijmateriaal HW TC06</li> </ul> | <ul style="list-style-type: none"> <li>Optimale aanpassing aan de snijkwaliteit, aanvoersnelheid en materiaaldikte door verschillend aantal tanden</li> </ul> | <ul style="list-style-type: none"> <li>Asgat vergroten tegen meerprijs mogelijk tot Ø 50 mm</li> </ul> |

| Producteigenschappen |        |        |          |     |                |        |               | Bestelinformatie |   |              |
|----------------------|--------|--------|----------|-----|----------------|--------|---------------|------------------|---|--------------|
| Ø D [mm]             | B [mm] | b [mm] | Ø d [mm] | Z   | Snijkwaliteit* | NL**   | Spaanhoek [°] | VE [St.]         | V | Bestelnummer |
| 150                  | 3,2    | 2,2    | 30       | 36  | ▲▲             | 2/7/42 | 10            | 1                |   | 58100099     |
| 150                  | 3,2    | 2,2    | 30       | 48  | ▲▲▲            | 2/7/42 | 10            | 1                |   | 58100101     |
| 180                  | 3,2    | 2,2    | 30       | 54  | ▲▲▲            | 2/7/42 | 10            | 1                |   | 58100015     |
| 200                  | 3,2    | 2,2    | 30       | 48  | ▲▲▲            | 2/7/42 | 10            | 1                |   | 58100091     |
| 200                  | 3,2    | 2,2    | 30       | 64  | ▲▲▲            | 2/7/42 | 10            | 1                |   | 58100025     |
| 235                  | 2,8    | 1,8    | 30       | 36  | ▲▲▲            | 2/7/42 | 15            | 1                |   | 50110117     |
| 235                  | 2,8    | 1,8    | 30       | 48  | ▲▲▲▲           | 2/7/42 | 15            | 1                |   | 58110121     |
| 235                  | 2,8    | 1,8    | 30       | 64  | ▲▲▲▲           | 2/7/42 | 10            | 1                |   | 58110118     |
| 235                  | 3,2    | 2,2    | 30       | 34  | ▲▲             |        | 10            | 1                | o | 50100193     |
| 240                  | 2,8    | 1,8    | 30       | 36  | ▲▲▲            | 2/7/42 | 15            | 1                |   | 50110123     |
| 240                  | 2,8    | 1,8    | 30       | 48  | ▲▲▲▲           | 2/7/42 | 15            | 1                |   | 50110124     |
| 250                  | 3,2    | 2,2    | 30       | 40  | ▲▲▲            | Combi3 | 10            | 1                |   | 58100018     |
| 250                  | 3,2    | 2,2    | 30       | 48  | ▲▲▲▲           | Combi3 | 10            | 1                |   | 58100026     |
| 250                  | 3,2    | 2,2    | 30       | 60  | ▲▲▲▲           | Combi3 | 10            | 1                |   | 58100031     |
| 250                  | 3,2    | 2,2    | 30       | 80  | ▲▲▲▲           | Combi3 | 10            | 1                |   | 58100038     |
| 254                  | 3,0    | 2,2    | 20/30    | 40  | ▲▲▲            |        | 10            | 1                |   | 58114108     |
| 254                  | 3,2    | 2,2    | 30       | 40  | ▲▲▲            | Combi3 | 10            | 1                |   | 58120067     |
| 254                  | 3,2    | 2,2    | 30       | 60  | ▲▲▲▲           | Combi3 | 10            | 1                |   | 58120068     |
| 260                  | 3,2    | 2,2    | 30       | 40  | ▲▲▲            | Combi3 | 10            | 1                |   | 58110175     |
| 260                  | 3,2    | 2,2    | 30       | 60  | ▲▲▲▲           | Combi3 | 10            | 1                |   | 58100254     |
| 270                  | 3,2    | 2,2    | 30       | 42  | ▲▲▲            |        | 10            | 1                | o | 50110064     |
| 270                  | 3,2    | 2,2    | 30       | 60  | ▲▲▲▲           | Combi3 | 10            | 1                |   | 58110182     |
| 280                  | 3,2    | 2,2    | 30       | 48  | ▲▲▲▲           | Combi3 | 10            | 1                |   | 58110136     |
| 300                  | 3,2    | 2,2    | 30       | 48  | ▲              | Combi3 | 10            | 1                |   | 58100250     |
| 300                  | 3,2    | 2,2    | 30       | 60  | ▲▲             | Combi3 | 10            | 1                |   | 58100027     |
| 300                  | 3,2    | 2,2    | 30       | 72  | ▲▲             | Combi3 | 10            | 1                |   | 58100032     |
| 300                  | 3,2    | 2,2    | 30       | 96  | ▲▲▲            | Combi3 | 10            | 1                |   | 58100251     |
| 305                  | 3,2    | 2,2    | 30       | 48  | ▲              | Combi3 | 10            | 1                |   | 58120065     |
| 305                  | 3,2    | 2,2    | 30       | 60  | ▲▲             | Combi3 | 10            | 1                |   | 58120066     |
| 315                  | 3,2    | 2,2    | 30       | 48  | ▲              | Combi3 | 10            | 1                |   | 58100252     |
| 315                  | 3,2    | 2,2    | 30       | 60  | ▲▲             | Combi3 | 10            | 1                |   | 58100253     |
| 350                  | 3,5    | 2,5    | 30       | 54  | ▲▲             | Combi3 | 10            | 1                |   | 58100021     |
| 350                  | 3,5    | 2,5    | 30       | 72  | ▲▲             | Combi3 | 10            | 1                |   | 58100028     |
| 350                  | 3,5    | 2,5    | 30       | 84  | ▲▲             | Combi3 | 10            | 1                |   | 58100033     |
| 350                  | 3,5    | 2,5    | 30       | 108 | ▲▲▲            | Combi3 | 10            | 1                |   | 58100040     |
| 400                  | 3,5    | 2,5    | 30       | 60  | ▲▲             | Combi3 | 10            | 1                |   | 58100022     |
| 400                  | 3,5    | 2,5    | 30       | 84  | ▲▲▲            | Combi3 | 10            | 1                |   | 58100029     |
| 400                  | 3,5    | 2,5    | 30       | 96  | ▲▲▲            | Combi3 | 10            | 1                |   | 58100034     |
| 400                  | 3,5    | 2,5    | 30       | 120 | ▲▲▲            | Combi3 | 10            | 1                |   | 58100041     |

\* Snijkwaliteit ▲ Zeer grove snede, ▲▲ Grove snede, ▲▲▲ Fijne snede, ▲▲▲▲ Zeer fijne snede  
 \*\* Extra gaten: Combi1 komt overeen met 2/10/60 + 2/7/42 Combi2 komt overeen met 2/7/42 + 2/9/46 en 2/10/60 Combi3 = 2/10/60 + 2/9/46 + 2/9.5/46.5 + 2/7/42 Combi5 = 2/7/110 + 2/9/110 + 2/8.4/130 + 2/14/110 + 4/9/100 + 4/19/120 Combi7 = 2/9/110 + 2/10/80 + 2/11/85 + 2/11/115 + 2/11/148 + 2/14/100 + 2/14/125 + 2/19/120  
 Geschikte reduceerringen vindt u aan het einde van dit hoofdstuk

| Producteigenschappen |        |        |          |     |                |        |               | Bestelinformatie |          |   |              |
|----------------------|--------|--------|----------|-----|----------------|--------|---------------|------------------|----------|---|--------------|
| Ø D [mm]             | B [mm] | b [mm] | Ø d [mm] | Z   | Snijkwaliteit* | NL**   | Spaanhoek [°] |                  | VE [St.] | V | Bestelnummer |
| 450                  | 3,8    | 2,8    | 30       | 66  | ▲▲             | Combi3 | 10            |                  | 1        |   | 58100023     |
| 450                  | 3,8    | 2,8    | 30       | 108 | ▲▲▲            | Combi3 | 10            |                  | 1        |   | 58100060     |
| 500                  | 3,8    | 2,8    | 30       | 72  | ▲▲             | Combi3 | 10            |                  | 1        |   | 58100024     |
| 550                  | 4,0    | 3,0    | 30       | 64  | ▲              | Combi3 | 10            |                  | 1        |   | 58120070     |

## HW ZWS-1 Afkort en zuiversneden zaagblad HW - Wisseltand met ashoek

Product

Tekening

Machine

Toepassing

Uitvoering

LOW NOISE

3-0-1

HW TC06

WSA

|  |   |   |  |
|--|---|---|--|
| <p>Machine / gebruiksaanwijzing</p> <ul style="list-style-type: none"> <li>• Tafelcirkelzagen</li> <li>• Speciale machines</li> <li>• Voor formaatsneden in plaatmaterialen</li> </ul> | <p>Uitvoering</p> <ul style="list-style-type: none"> <li>• Tandvorm: wisseltand met ashoek 'WS'</li> <li>• Snijmateriaal HW TC06</li> </ul> | <p>Voordelen</p> <ul style="list-style-type: none"> <li>• Optimale aanpassing aan snijkwaliteit, aanzetsnelheid en materiaaldikte door verschillende rijen tanden</li> <li>• Verminderde snijdruk door de wisselende ashoek</li> <li>• Lange standtijd zorgen voor de nodige productiviteit en rendabiliteit</li> </ul> | <p>Informatie - Tip</p> <ul style="list-style-type: none"> <li>• Asgat vergroten tegen meerprijs mogelijk tot Ø 50 mm</li> </ul> |
|--|---|---|--|

| Producteigenschappen |        |        |          |    |                |        |               | Bestelinformatie |          |   |              |
|----------------------|--------|--------|----------|----|----------------|--------|---------------|------------------|----------|---|--------------|
| Ø D [mm]             | B [mm] | b [mm] | Ø d [mm] | Z  | Snijkwaliteit* | NL**   | Spaanhoek [°] |                  | VE [St.] | V | Bestelnummer |
| 250                  | 3,2    | 2,2    | 30       | 40 | ▲▲             | Combi3 | 10            |                  | 1        |   | 58100700     |
| 250                  | 3,2    | 2,2    | 30       | 60 | ▲▲▲            | Combi3 | 10            |                  | 1        |   | 58100701     |
| 300                  | 3,2    | 2,2    | 30       | 48 | ▲▲             | Combi3 | 10            |                  | 1        |   | 58100702     |
| 300                  | 3,2    | 2,2    | 30       | 96 | ▲▲▲▲           | Combi3 | 10            |                  | 1        |   | 58100703     |
| 350                  | 3,5    | 2,5    | 30       | 54 | ▲▲             | Combi3 | 10            |                  | 1        |   | 58100704     |

\* **Snijkwaliteit** ▲ Zeer grove snede, ▲▲ Grove snede, ▲▲▲ Fijne snede, ▲▲▲▲ Zeer fijne snede  
 \*\* **Extra gaten:** **Combi1** komt overeen met 2/10/60 + 2/7/42 **Combi2** komt overeen met 2/7/42 + 2/9/46 en 2/10/60 **Combi3** = 2/10/60 + 2/9/46 + 2/9.5/46.5 + 2/7/42 **Combi5** = 2/7/110 + 2/9/110 + 2/8.4/130 + 2/14/110 + 4/9/100 + 4/19/120 **Combi7** = 2/9/110 + 2/10/80 + 2/11/85 + 2/11/115 + 2/11/148 + 2/14/100 + 2/14/125 + 2/19/120  
 Geschikte **reduceerringen** vindt u aan het einde van dit hoofdstuk

HW

# Matador 5

Formaat-cirkelzaagbladen HW - vlakland-wisseltand-wisseltand

Product



Tekening

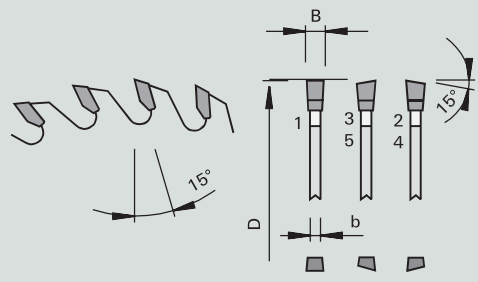

Machine



Toepassing



Uitvoering



|  |   |   |   |
|--|---|---|---|
| <p>Machine / gebruiksaanwijzing</p> <ul style="list-style-type: none"> <li>Tafelcirkelzagen</li> <li>Kap- en radiaal-cirkelzagen</li> <li>Voor een zuivere snede in plaatmaterialen, massief hout en kunststoffen</li> </ul> | <p>Uitvoering</p> <ul style="list-style-type: none"> <li>Tandvorm: vlakland-wisseltand-wisseltand "F-WS-WS"</li> <li>Tandbezetting: HW TC04 plus</li> </ul> | <p>Voordelen</p> <ul style="list-style-type: none"> <li>Optimale snijkwaliteit voor dwarsneden (afkorten)</li> <li>Optimale zuivere snede door speciale tandgeometrie</li> <li>Extreem lange standtijd</li> <li>Geluidsreductie door laserornamenten</li> </ul> | <p>Informatie - Tip</p> <ul style="list-style-type: none"> <li>Nmax absoluut niet overschrijden !!</li> </ul> |
|--|---|---|---|

| Producteigenschappen |      |      |      |     |                |        |            |  |       | Bestelinformatie |   |   |
|----------------------|------|------|------|-----|----------------|--------|------------|--|-------|------------------|---|---|
| Ø D                  | B    | b    | Ø d  | Z   | Snijkwaliteit* | NL**   | Spaanhoeek |  |       | VE               | V | Bestelnummer  |
| [mm]                 | [mm] | [mm] | [mm] |     |                |        | [°]        |  |       | [St.]            |   |   |
| 180                  | 3.0  | 2.2  | 30   | 60  | ▲▲▲▲           | 4/6/52 | 15         |  |       | 1                |   | 58808701  |
| 200                  | 3.0  | 2.2  | 30   | 65  | ▲▲▲▲           | Combi3 | 15         |  |       | 1                |   | 58808702  |
| 220                  | 3.0  | 2.2  | 30   | 70  | ▲▲▲▲           | 8/6/52 | 15         |  |       | 1                | ⊕ | 58808712  |
| 220                  | 3.0  | 2.2  | 40   | 70  | ▲▲▲▲           | 8/6/52 | 15         |  |       | 1                | ⊕ | 58808703  |
| 240                  | 3.0  | 2.2  | 30   | 75  | ▲▲▲▲           | 8/6/52 | 15         |  |       | 1                | ⊕ | 58808704  |
| 250                  | 3.0  | 2.2  | 30   | 80  | ▲▲▲▲           | Combi3 | 15         |  |       | 1                |   | 58808706  |
| 280                  | 3.0  | 2.2  | 30   | 85  | ▲▲▲▲           | Combi3 | 15         |  |       | 1                |   | 58808705  |
| 300                  | 3.0  | 2.2  | 30   | 100 | ▲▲▲▲           | Combi3 | 15         |  |       | 1                |   | 58808708  |
| 300                  | 4.0  | 3.2  | 30   | 100 | ▲▲▲▲           | Combi3 | 15         |  | Fimal | 1                |   | 58808713 <span style="color: red; font-weight: bold;">NEUW</span> |
| 303                  | 3.2  | 2.2  | 30   | 100 | ▲▲▲▲           | Combi3 | 15         |  |       | 1                |   | 58808707  |
| 350                  | 3.0  | 2.2  | 30   | 100 | ▲▲▲▲           | Combi3 | 15         |  |       | 1                |   | 58808709  |
| 500                  | 3.6  | 2.8  | 30   | 145 | ▲▲▲▲           | Combi3 | 15         |  |       | 1                |   | 58808710  |
| 550                  | 4.0  | 3.2  | 30   | 160 | ▲▲▲▲           | Combi3 | 15         |  |       | 1                |   | 58808711  |

\* Snijkwaliteit ▲ Zeer grove snede, ▲▲ Grove snede, ▲▲▲▲ Fijne snede, ▲▲▲▲▲ Zeer fijne snede

\*\* Extra gaten: Combi1 komt overeen met 2/10/60 + 2/7/42 Combi2 komt overeen met 2/7/42 + 2/9/46 en 2/10/60 Combi3 = 2/10/60 + 2/9/46 + 2/9.5/46.5 + 2/7/42 Combi5 = 2/7/110 + 2/9/110 + 2/8.4/130 + 2/14/110 + 4/9/100 + 4/19/120 Combi7 = 2/9/110 + 2/10/80 + 2/11/85 + 2/11/115 + 2/11/148 + 2/14/100 + 2/14/125 + 2/19/120

Geschikte reduceerringen vindt u aan het einde van dit hoofdstuk

**HW**

**TRF**

Formaat cirkelzaagblad HW - trapezium-vlaktand

Product



Tekening

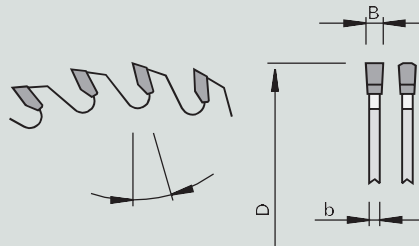

Machine



Toepassing



Uitvoering



Machine / gebruiksaanwijzing

- Handcirkelzagen
- Tafelcirkelzagen
- Verticale platenopdeezagen
- voor formaatsneden in kunststof beplakte plaatmaterialen

Uitvoering

- tandvorm: trapezium-vlaktand 'TR-F'
- Snijmateriaal HW TC06

Voordelen

Informatie - Tip

- Asgat vergroten tegen meerprijs mogelijk tot Ø 50 mm

Producteigenschappen

Bestelinformatie

| Ø D [mm] | B [mm] | b [mm] | Ø d [mm] | Z   | Snijkwaliteit* | NL**     | Spaanhoek [°] | VE [St.] | V | Bestelnummer         |
|----------|--------|--------|----------|-----|----------------|----------|---------------|----------|---|----------------------|
| 120      | 1,8    | 1,2    | 20       | 40  | ▲▲             |          | 5             | 1        |   | 58104063             |
| 160      | 2,2    | 1,6    | 20       | 48  | ▲▲             | 2/7/32   | 5             | 1        |   | 58110161             |
| 160      | 2,2    | 1,6    | 20       | 56  | ▲▲▲            | 2/7/32   | 5             | 1        |   | 58110142             |
| 190      | 2,2    | 1,6    | 30       | 56  | ▲▲▲            |          | 5             | 1        |   | 58458779             |
| 190      | 2,6    | 2,0    | 20FX     | 54  | ▲▲▲            | Fast-Fix | 5             | 1        | o | 58110229 <b>NIUW</b> |
| 216      | 3,2    | 2,2    | 30       | 60  | ▲▲▲            |          | 5             | 1        |   | 58458780             |
| 220      | 3,2    | 2,2    | 30       | 64  | ▲▲▲            | 2/7/42   | 5             | 1        |   | 58100399             |
| 232      | 3,2    | 2,2    | 30       | 64  | ▲▲▲            |          | 5             | 1        |   | 58458781             |
| 250      | 3,2    | 2,2    | 30       | 60  | ▲▲             | Combi3   | 5             | 1        |   | 58100385             |
| 250      | 3,2    | 2,2    | 30       | 80  | ▲▲▲            | Combi3   | 5             | 1        |   | 58100386             |
| 300      | 3,2    | 2,2    | 30       | 72  | ▲▲             | Combi3   | 5             | 1        |   | 58100387             |
| 300      | 3,2    | 2,2    | 30       | 96  | ▲▲▲            | Combi3   | 5             | 1        |   | 58100388             |
| 350      | 3,5    | 2,5    | 30       | 72  | ▲▲             | Combi3   | 10            | 1        |   | 58100300             |
| 350      | 3,5    | 2,5    | 30       | 108 | ▲▲▲            | Combi3   | 10            | 1        |   | 58100389             |

\* Snijkwaliteit ▲ Zeer grove snede, ▲▲ Grove snede, ▲▲▲ Fijne snede, ▲▲▲▲ Zeer fijne snede



\*\* Extra gaten: Combi1 komt overeen met 2/10/60 + 2/7/42 Combi2 komt overeen met 2/7/42 + 2/9/46 en 2/10/60 Combi3 = 2/10/60 + 2/9/46 + 2/9.5/46.5 + 2/7/42 Combi5 = 2/7/110 + 2/9/110 + 2/8.4/130 + 2/14/110 + 4/9/100 + 4/19/120 Combi7 = 2/9/110 + 2/10/80 + 2/11/85 + 2/11/115 + 2/11/148 + 2/14/100 + 2/14/125 + 2/19/120

Geschikte reduceerringen vindt u aan het einde van dit hoofdstuk

HW

TRF - 1

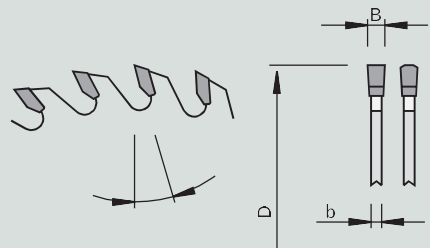
Formaat cirkelzaagblad HW - trapezium-vlaktand

|  |  |  |   |   |
|--|--|--|---|---|
| <p>Product</p>  | <p>Tekening</p>  | <p>Machine</p>  | <p>Toepassing</p>  | <p>Uitvoering</p> <p>3-0-1</p> <p>HW<br/>TC04<br/>plus</p> <p>TR-<br/>F</p> |
|--|--|--|---|---|

|  |   |  |  |
|--|---|--|--|
| <p>Machine / gebruiksaanwijzing</p> <ul style="list-style-type: none"> <li>• Tafelcirkelzaagbladen</li> <li>• Verticale platenopdeelzagen</li> <li>• voor formaatsneden in kunststof beplakte plaatmaterialen</li> </ul> | <p>Uitvoering</p> <ul style="list-style-type: none"> <li>• Tandvorm: trapezium-vlaktand "TR-F"</li> <li>• Snijmateriaal HW TC04 plus</li> </ul> | <p>Voordelen</p> <ul style="list-style-type: none"> <li>• Verbeterde snijkwaliteit door geoptimaliseerde snijgeometrie</li> <li>• Geluidsreductie door laser-ornamenten</li> </ul> | <p>Informatie - Tip</p> <ul style="list-style-type: none"> <li>• Speciaal geschikt voor met kunststof bekleed plaatmateriaal op basis van hout en multiplexplaten</li> </ul> |
|--|---|--|--|

| Producteigenschappen |        |        |          |     |                |        |               | Bestelinformatie |   |              |
|----------------------|--------|--------|----------|-----|----------------|--------|---------------|------------------|---|--------------|
| Ø D [mm]             | B [mm] | b [mm] | Ø d [mm] | Z   | Snijkwaliteit* | NL**   | Spaanhoek [°] | VE [St.]         | V | Bestelnummer |
| 315                  | 3,2    | 2,2    | 30       | 96  | ▲▲▲            | Combi3 | 5             | 1                |   | 58803823     |
| 300                  | 3,2    | 2,2    | 30       | 96  | ▲▲▲            | Combi3 | 5             | 1                |   | 58458788     |
| 350                  | 3,5    | 2,5    | 30       | 72  | ▲▲             | Combi3 | 10            | 1                |   | 58807830     |
| 350                  | 3,5    | 2,5    | 30       | 108 | ▲▲▲            | Combi3 | 10            | 1                |   | 58807831     |

\* Snijkwaliteit ▲ Zeer grove snede, ▲▲ Grove snede, ▲▲▲ Fijne snede, ▲▲▲▲ Zeer fijne snede

\*\* Extra gaten: Combi1 komt overeen met 2/10/60 + 2/7/42 Combi2 komt overeen met 2/7/42 + 2/9/46 en 2/10/60 Combi3 = 2/10/60 + 2/9/46 + 2/9,5/46,5 + 2/7/42 Combi5 = 2/7/110 + 2/9/110 + 2/8,4/130 + 2/14/110 + 4/9/100 + 4/19/120 Combi7 = 2/9/110 + 2/10/80 + 2/11/85 + 2/11/115 + 2/11/148 + 2/14/100 + 2/14/125 + 2/19/120

Geschikte reduceerringen vindt u aan het einde van dit hoofdstuk

## HW Cirkelzaagbladen-set HW - een klus voor twee

Set = HW Hoofdcirkelzaagblad en Ritszaag

Product

Tekening

Machine

Toepassing

Uitvoering



2-0-6

HW  
TC06

TR-  
F

Machine / gebruiksaanwijzing

- Tafelcirkelzagen met voorrits-aggregaat
- Platenopdeelzagen met voorrits-aggregaat
- Voor afwerksnedes in met kunststof bekleed plaatmateriaal op basis van hout

Uitvoering

- Cirkelzaagbladen-set bestaande uit hoofd- en voorritszaagblad en reduceerring
- Tandbezetting: HW TC06

Voordelen

- Set exact op elkaar afgestemd, dit garandeert een uitstekende snijkwaliteit bij afwerksnedes
- Snelle, eenvoudige instelling van rits- en hoofdzaag
- Lange standtijd door speciaal hardmetaal
- Geluidsreductie door laserornamenten

Informatie - Tip

Producteigenschappen

Bestelinformatie

|                         |                          | VE [St.] | V | Bestelnummer |
|-------------------------|--------------------------|----------|---|--------------|
| Cirkelzaagbladen-Set HW |                          | 1        |   | 50804303     |
| Toebehoren              | Afmeting [mm]            | VE [St.] | V | Bestelnummer |
| Hoofdcirkelzaagblad     | 300x3,2x2,2x30 Z=72 TR-F | 1        |   | 58100387     |
| Ritscirkelzaagblad      | 125x3,35x2,4x22 Z=24 WS  | 1        |   | 50806200     |
| Reduceerringen          | 22x2,0x20                | 1        |   | 161887       |

Producteigenschappen

Bestelinformatie

|                         |                          | VE [St.] | V | Bestelnummer         |
|-------------------------|--------------------------|----------|---|----------------------|
| Cirkelzaagbladen-Set HW |                          | 1        |   | 58804304 <b>NIJW</b> |
| Toebehoren              | Afmeting [mm]            | VE [St.] | V | Bestelnummer         |
| Hoofdcirkelzaagblad     | 350x3,5x2,4x30 Z=72 TR-F | 1        |   | 58807830             |
| Ritscirkelzaagblad      | 180x3,6x2,4x22 Z=36 F    | 1        |   | 58806210             |
| Reduceerringen          | 22x2,0x20                | 1        |   | 161887               |

\* **Snijkwaliteit** ▲ Zeer grove snede, ▲▲ Grove snede, ▲▲▲ Fijne snede, ▲▲▲▲ Zeer fijne snede





\*\* **Extra gaten:** **Combi1** komt overeen met 2/10/60 + 2/7/42 **Combi2** komt overeen met 2/7/42 + 2/9/46 en 2/10/60 **Combi3** = 2/10/60 + 2/9/46 + 2/9.5/46.5 + 2/7/42 **Combi5** = 2/7/110 + 2/9/110 + 2/8.4/130 + 2/14/110 + 4/9/100 + 4/19/120 **Combi7** = 2/9/110 + 2/10/80 + 2/11/85 + 2/11/115 + 2/11/148 + 2/14/100 + 2/14/125 + 2/19/120

Geschikte **reduceerringen** vindt u aan het einde van dit hoofdstuk

HW

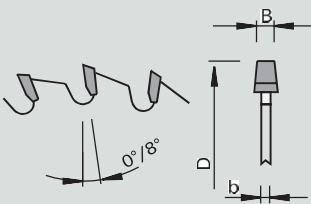
RSK - nn-System

Voorrits cirkelzaagblad HW - conische-vlaktand - nn-systeem

|  |   |  |   |   |
|--|---|--|---|---|
| <p>Product</p>  | <p>Tekening</p>  | <p>Machine</p>  | <p>Toepassing</p>  | <p>Uitvoering</p>  <p>3-0-1</p> <p>HW<br/>TC04<br/>plus</p> <p>KO-<br/>F</p> |
|--|---|--|---|---|

|  |  |  |  |
|--|--|--|--|
| <p>Machine / gebruiksaanwijzing</p> <ul style="list-style-type: none"> <li>• Tafelcirkelzagen</li> <li>• Voor het voorritsen van met kunststof beplakte plaatmaterialen</li> </ul> | <p>Uitvoering</p> <ul style="list-style-type: none"> <li>• Speciale NoNoise-spaanruimte-geometrie</li> <li>• Tandvorm: conische-vlaktand 'KO-F'</li> <li>• Snijmateriaal HW TC04 plus</li> </ul> | <p>Voordelen</p> <ul style="list-style-type: none"> <li>• Snel verstelbaar</li> <li>• Universeel inzetbaar</li> <li>• Beste snijkwaliteit door verbeterde loopnauwkeurigheid volgens schema</li> <li>• Vermindering van de ritsdiepte</li> <li>• Extreem geluidsarm</li> <li>• Geluidsreducering met ca. 6 dB(A) bij stationair draaien</li> <li>• Zeer goede snijkwaliteit bij alle standaardcoatings</li> <li>• Lange standtijden zorgen voor de nodige productiviteit en rendabiliteit</li> </ul> | <p>Informatie - Tip</p> <ul style="list-style-type: none"> <li>• Door hoogteverstelling van de as op snijbreedte van de hoofdzaag in te stellen</li> <li>• 1 mm ritsdiepte = 0,21 mm snijbreedte</li> <li>• Optimale voorrits-diepte 1,0 - 2,0 mm</li> </ul> |
|--|--|--|--|

| Producteigenschappen |         |        |          |    |                |               | Bestelinformatie  |          |   |              |
|----------------------|---------|--------|----------|----|----------------|---------------|-------------------|----------|---|--------------|
| Ø D [mm]             | B [mm]  | b [mm] | Ø d [mm] | Z  | Snijkwaliteit* | Spaanhoek [°] |                   | VE [St.] | V | Bestelnummer |
| 100                  | 3,2-4,0 | 2,5    | 20       | 20 | ▲▲▲▲           | 8             | Schelling         | 1        |   | 58807950     |
| 120                  | 3,2-4,0 | 2,5    | 20       | 24 | ▲▲▲▲           | 8             | Altendorf, SCM    | 1        |   | 58807951     |
| 120                  | 3,2-4,0 | 2,5    | 22       | 24 | ▲▲▲▲           | 8             | Altendorf, Martin | 1        |   | 58807952     |
| 125                  | 3,1-4,0 | 2,5    | 20       | 24 | ▲▲▲▲           | 8             | Panhans, Paolini  | 1        |   | 58807953     |

\* Snijkwaliteit ▲ Zeer grove snede, ▲▲ Grove snede, ▲▲▲ Fijne snede, ▲▲▲▲ Zeer fijne snede

\*\* Extra gaten: Combi1 komt overeen met 2/10/60 + 2/7/42 Combi2 komt overeen met 2/7/42 + 2/9/46 en 2/10/60 Combi3 = 2/10/60 + 2/9/46 + 2/9,5/46,5 + 2/7/42 Combi5 = 2/7/110 + 2/9/110 + 2/8,4/130 + 2/14/110 + 4/9/100 + 4/19/120 Combi7 = 2/9/110 + 2/10/80 + 2/11/85 + 2/11/115 + 2/11/148 + 2/14/100 + 2/14/125 + 2/19/120

Geschikte reduceerringen vindt u aan het einde van dit hoofdstuk



DP

RSK

Voorrits cirkelzaagbladen DP - conische-vlaktand KO-F

Product



Tekening

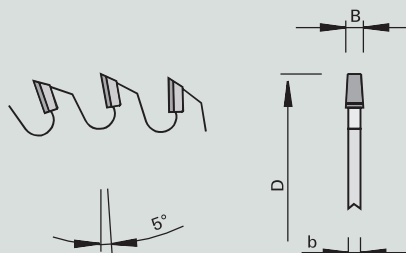

Machine



Toepassing



Uitvoering



4,5 mm

3-0-1

KO-F

Machine / gebruiksaanwijzing

- Tafelcirkelzagen
- Voor het voorritsen van beplakte plaatmaterialen

Uitvoering

- Diamantsnijkmanten in gepolijste uitvoering
- Tandvorm: conische vlaktand "KO-F"
- Snijmateriaal DP
- Naslijpzone 4,5 mm

Voordelen

- Korte levertijden

Informatie - Tip

- Inzetten in meeloop

Producteigenschappen

Bestelinformatie

| Ø D [mm] | B [mm]  | b [mm] | Ø d [mm] | Z  | Snijkwaliteit* | Spaanhoek [°] |                   | VE [St.] | V | Bestelnummer |
|----------|---------|--------|----------|----|----------------|---------------|-------------------|----------|---|--------------|
| 120      | 3,1-3,9 | 2,5    | 22       | 16 | ▲▲▲▲           | 5             | Altendorf, Martin | 1        | s | 58750101     |

\* Snijkwaliteit ▲ Zeer grove snede, ▲▲ Grove snede, ▲▲▲ Fijne snede, ▲▲▲▲ Zeer fijne snede





\*\* Extra gaten: Combi1 komt overeen met 2/10/60 + 2/7/42 Combi2 komt overeen met 2/7/42 + 2/9/46 en 2/10/60 Combi3 = 2/10/60 + 2/9/46 + 2/9.5/46.5 + 2/7/42 Combi5 = 2/7/110 + 2/9/110 + 2/8.4/130 + 2/14/110 + 4/9/100 + 4/19/120 Combi7 = 2/9/110 + 2/10/80 + 2/11/85 + 2/11/115 + 2/11/148 + 2/14/100 + 2/14/125 + 2/19/120

Geschikte reduceerringen vindt u aan het einde van dit hoofdstuk

HW

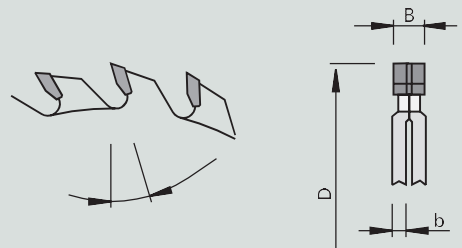
RS2

Voorrits cirkelzaagblad HW - verstelbaar vlaktand F

|   |  |  |   |                          |
|---|--|--|---|--------------------------|
| Product   | Tekening   | Machine  | Toepassing  | Uitvoering               |
|  |  | <br> |  | 3-0-1<br>HW<br>TC03<br>F |

|   |  |  |  |
|---|--|--|--|
| Machine / gebruiksaanwijzing  | Uitvoering   | Voordelen  | Informatie - Tip   |
| <ul style="list-style-type: none"> <li>Tafelcirkelzagen</li> <li>Platenopdeelzagen</li> <li>Platenopdeelzagen met instelbare voorritsaggregaat</li> <li>Voor het voorritsen van met kunststof beplakte plaatmaterialen</li> </ul> | <ul style="list-style-type: none"> <li>Tandvorm: vlaktand "F"</li> <li>Tandbezetting: HW TC03</li> </ul> | <ul style="list-style-type: none"> <li>Universeel inzetbaar</li> </ul> | <ul style="list-style-type: none"> <li>Tweedelig, snijbreedte dmv tussenringen instelbaar</li> </ul> |

| Producteigenschappen |         |        |          |      |                |               | Bestelinformatie |          |   |              |
|----------------------|---------|--------|----------|------|----------------|---------------|------------------|----------|---|--------------|
| Ø D [mm]             | B [mm]  | b [mm] | Ø d [mm] | Z    | Snijkwaliteit* | Spaanhoek [°] |                  | VE [St.] | V | Bestelnummer |
| 70                   | 2,8-3,6 | 2,2    | 20       | 2x8  | ▲▲▲▲           | 12            |                  | 1        | o | 50445100     |
| 80                   | 2,8-3,6 | 2,2    | 20       | 2x10 | ▲▲▲▲           | 12            |                  | 1        |   | 58802435     |
| 100                  | 2,8-3,6 | 2,2    | 20       | 2x10 | ▲▲▲▲           | 12            |                  | 1        |   | 58110190     |
| 100                  | 2,8-3,6 | 2,2    | 22       | 2x10 | ▲▲▲▲           | 12            |                  | 1        |   | 58110188     |
| 105                  | 2,8-3,6 | 2,2    | 20       | 2x10 | ▲▲▲▲           | 12            |                  | 1        |   | 58110171     |
| 120                  | 2,8-3,6 | 2,2    | 20       | 2x12 | ▲▲▲▲           | 12            |                  | 1        |   | 58110186     |
| 120                  | 2,8-3,6 | 2,2    | 22       | 2x12 | ▲▲▲▲           | 12            |                  | 1        |   | 58110187     |
| 125                  | 2,8-3,6 | 2,2    | 20       | 2x12 | ▲▲▲▲           | 12            |                  | 1        |   | 58110206     |
| 125                  | 2,8-3,6 | 2,2    | 22       | 2x12 | ▲▲▲▲           | 12            |                  | 1        |   | 58110204     |

\* Snijkwaliteit ▲ Zeer grove snede, ▲▲ Grove snede, ▲▲▲ Fijne snede, ▲▲▲▲ Zeer fijne snede

\*\* Extra gaten: Combi1 komt overeen met 2/10/60 + 2/7/42 Combi2 komt overeen met 2/7/42 + 2/9/46 en 2/10/60 Combi3 = 2/10/60 + 2/9/46 + 2/9,5/46,5 + 2/7/42 Combi5 = 2/7/110 + 2/9/110 + 2/8,4/130 + 2/14/110 + 4/9/100 + 4/19/120 Combi7 = 2/9/110 + 2/10/80 + 2/11/85 + 2/11/115 + 2/11/148 + 2/14/100 + 2/14/125 + 2/19/120

Geschikte reduceerringen vindt u aan het einde van dit hoofdstuk

**HW** **RSVS**  
Voorrits cirkelzaagblad HW - verstelbaar wisseltand WS

|         |          |         |            |  |
|---------|----------|---------|------------|--|
| Product | Tekening | Machine | Toepassing | Uitvoering                             |
|         |          |         |            | 3-0-1<br>HW<br><b>TC03</b><br>ES<br>WS |

|   |  |   |  |
|---|--|---|--|
| Machine / gebruiksaanwijzing<br><ul style="list-style-type: none"> <li>Tafelcirkelzagen</li> <li>Platenopdeelzagen</li> <li>Platenopdeelzagen met instelbare voorritsaggregaat</li> <li>Voor het voorritsen van met kunststof beplakte plaatmaterialen</li> </ul> | Uitvoering<br><ul style="list-style-type: none"> <li>Tandvorm: tot Ø 140 mm wisseltand 'WS'</li> <li>Tandvorm: vanaf Ø 160 mm eenzijdig spits 'ES'</li> <li>Snijmateriaal HW TC03</li> </ul> | Voordelen<br><ul style="list-style-type: none"> <li>Kleinere motorbelasting door WS-tandvorm</li> </ul> | Informatie - Tip<br><ul style="list-style-type: none"> <li>58807910: Tweedelig, snijbreedte dmv tussenringen instelbaar</li> </ul> |
|---|--|---|--|

| Producteigenschappen               |         |               |          |                                 |                |               | Bestelinformatie         |          |   |              |
|------------------------------------|---------|---------------|----------|---------------------------------|----------------|---------------|--------------------------|----------|---|--------------|
| Ø D [mm]                           | B [mm]  | b [mm]        | Ø d [mm] | Z                               | Snijkwaliteit* | Spaanhoek [°] |                          | VE [St.] | V | Bestelnummer |
| 120                                | 2,8-3,8 | 2,2           | 22       | 2x12                            | ▲▲▲▲           | 12            | Martin NC versteleenheid | 1        |   | 50807854     |
| 120                                | 2,8-3,8 | 2,2           | 50       | 2x12                            | ▲▲▲▲           | 12            | Altendorf, Martin        | 1        |   | 50807902     |
| 140                                | 2,8-3,8 | 2,0           | 36       | 2x12                            | ▲▲▲▲           | 12            | Martin T75 PreX          | 1        |   | 50807909     |
| 160                                | 2,8-3,6 | 2,2           | 20       | 2x16                            | ▲▲▲▲           | 12            | CSM                      | 1        | o | 58807910     |
| Toebehoren                         |         | Afmeting [mm] |          |                                 |                |               |                          | VE [St.] | V | Bestelnummer |
| Kruiskopschroeven - met binnentorx |         | M5x6,8 T15    |          | Montageschroef voor binnenflens |                |               |                          | 10       |   | 180839       |
| Kruiskopschroeven - met binnentorx |         | M5x10,8 T15   |          | Montageschroef voor buitenflens |                |               |                          | 10       |   | 180840       |

\* Snijkwaliteit ▲ Zeer grove snede, ▲▲ Grove snede, ▲▲▲ Fijne snede, ▲▲▲▲ Zeer fijne snede

\*\* Extra gaten: Combi1 komt overeen met 2/10/60 + 2/7/42 Combi2 komt overeen met 2/7/42 + 2/9/46 en 2/10/60 Combi3 = 2/10/60 + 2/9/46 + 2/9.5/46.5 + 2/7/42 Combi5 = 2/7/110 + 2/9/110 + 2/8.4/130 + 2/14/110 + 4/9/100 + 4/19/120 Combi7 = 2/9/110 + 2/10/80 + 2/11/85 + 2/11/115 + 2/11/148 + 2/14/100 + 2/14/125 + 2/19/120

Geschikte reduceerringen vindt u aan het einde van dit hoofdstuk

## DP RSVS Voorrits cirkelzaagblad DP - verstelbaar wisseltand WS

|         |          |         |            |            |
|---------|----------|---------|------------|------------|
| Product | Tekening | Machine | Toepassing | Uitvoering |
|         |          |         |            |            |

|  |   |           |  |
|--|---|-----------|--|
| Machine / gebruiksaanwijzing   | Uitvoering  | Voordelen | Informatie - Tip   |
| <ul style="list-style-type: none"> <li>Tafelcirkelzagen</li> <li>Voor het voorritsen van diverse beplakte plaatmaterialen</li> </ul> | <ul style="list-style-type: none"> <li>Tandvorm: wisseltand "WS"</li> <li>Snijmateriaal DP</li> <li>Naslijpzone 4,5 mm</li> </ul> |           | <ul style="list-style-type: none"> <li>Tweedelig, snijbreedte dmv tussenringen instelbaar</li> <li>Inzet in meeloop</li> </ul> |

| Producteigenschappen |         |        |          |      |                |          |               |                          |          | Bestelinformatie |              |  |
|----------------------|---------|--------|----------|------|----------------|----------|---------------|--------------------------|----------|------------------|--------------|--|
| Ø D [mm]             | B [mm]  | b [mm] | Ø d [mm] | Z    | Snijkwaliteit* | NL**     | Spaanhoek [°] |                          | VE [St.] | V                | Bestelnummer |  |
| 120                  | 2,8-3,8 | 2,2    | 22       | 2x12 | ▲▲▲▲           | 2/3,8/42 | 8             | Altendorf, Martin        | 1        |                  | 50750102     |  |
| 120                  | 2,8-3,8 | 2,2    | 50       | 2x12 | ▲▲▲▲           | 4/6,2/62 | 8             | Altendorf versteleenheid | 1        | o                | 50750105     |  |

## HW KDF - Industry - Negatief Formaat cirkelzaagbladen HW - daktand-vlaktand Duplovit

|         |          |         |            |            |
|---------|----------|---------|------------|------------|
| Product | Tekening | Machine | Toepassing | Uitvoering |
|         |          |         |            |            |



|   |  |   |                  |
|---|--|---|------------------|
| Machine / gebruiksaanwijzing  | Uitvoering   | Voordelen   | Informatie - Tip |
| <ul style="list-style-type: none"> <li>Kap- en radiaal cirkelzagen</li> <li>Tafelcirkelzagen</li> <li>Verticale platenopdeelzagen</li> <li>Voor dwarssnedes bij profieldelen van kunststof en massief hout</li> </ul> | <ul style="list-style-type: none"> <li>Trilling- en geluiddempende ornamenten</li> <li>Extra spanningsgleuven</li> <li>Tandvorm: daktand-vlaktand Duplovit 'DA-F DU'</li> <li>Snijmateriaal HW TC06</li> </ul> | <ul style="list-style-type: none"> <li>Extreem geluidsarm door vibratie- en geluiddempende ornamenten en speciale spanningsgleuven</li> <li>Goede afwerking aan onderzijde ook zonder voorrits-zaagblad</li> <li>Beste snijkwaliteit</li> </ul> |                  |

| Producteigenschappen |        |        |          |    |                |        |               |  |          | Bestelinformatie |              |  |
|----------------------|--------|--------|----------|----|----------------|--------|---------------|--|----------|------------------|--------------|--|
| Ø D [mm]             | B [mm] | b [mm] | Ø d [mm] | Z  | Snijkwaliteit* | NL**   | Spaanhoek [°] |  | VE [St.] | V                | Bestelnummer |  |
| 250                  | 3,2    | 2,2    | 30       | 48 | ▲▲▲            | Combi3 | -5            |  | 1        |                  | 58804352     |  |
| 303                  | 3,2    | 2,2    | 30       | 60 | ▲▲▲▲           | Combi3 | -5            |  | 1        |                  | 58804279     |  |

\* Snijkwaliteit ▲ Zeer grove snede, ▲▲ Grove snede, ▲▲▲ Fijne snede, ▲▲▲▲ Zeer fijne snede  
 \*\* Extra gaten: Combi1 komt overeen met 2/10/60 + 2/7/42 Combi2 komt overeen met 2/7/42 + 2/9/46 en 2/10/60 Combi3 = 2/10/60 + 2/9/46 + 2/9,5/46,5 + 2/7/42 Combi5 = 2/7/110 + 2/9/110 + 2/8,4/130 + 2/14/110 + 4/9/100 + 4/19/120 Combi7 = 2/9/110 + 2/10/80 + 2/11/85 + 2/11/115 + 2/11/148 + 2/14/100 + 2/14/125 + 2/19/120  
 Geschikte reduceerringen vindt u aan het einde van dit hoofdstuk

## HW KDF - Industry

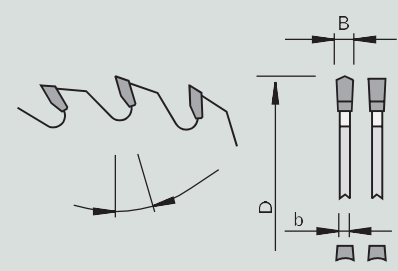
Formaat cirkelzaagbladen HW - daktand-vlaktand Duplovit



|   |  |   |   |  |
|---|--|---|---|--|
| Product   | Tekening   | Machine   | Toepassing  | Uitvoering                               |
|  |  |  |  | 3-0-1<br>HW<br><b>TC06</b><br>DA-F<br>DU |

|   |   |   |                  |
|---|---|---|------------------|
| Machine / gebruiksaanwijzing  | Uitvoering  | Voordelen   | Informatie - Tip |
| <ul style="list-style-type: none"> <li>Tafelcirkelzagen</li> <li>Vertikale platenopdeelzaagbladen</li> <li>Voor formaatsnedes in ruw en beplakt plaatmateriaal op basis van hout</li> </ul> | <ul style="list-style-type: none"> <li>Trilling- en geluiddempende ornamenten</li> <li>Extra spanningsseuven</li> <li>Tandvorm: daktand-vlaktand Duplovit 'DA-F DU'</li> <li>Snijmateriaal HW TC06</li> </ul> | <ul style="list-style-type: none"> <li>Extreem geluidsarm door vibratie- en geluiddempende ornamenten zoals speciale sleuf-combinaties</li> <li>Goede afwerking aan onderzijde ook zonder voorrits-zaagblad</li> <li>Beste snijkwaliteit</li> </ul> |                  |

| Producteigenschappen |        |        |          |    |                |        | Bestelinformatie |          |   |              |
|----------------------|--------|--------|----------|----|----------------|--------|------------------|----------|---|--------------|
| Ø D [mm]             | B [mm] | b [mm] | Ø d [mm] | Z  | Snijkwaliteit* | NL**   | Spaanhoek [°]    | VE [St.] | V | Bestelnummer |
| 220                  | 3,2    | 2,2    | 30       | 42 | ▲▲             | 2/7/42 | 10               |          | 1 | 58804281     |
| 250                  | 3,2    | 2,2    | 30       | 48 | ▲▲             | Combi3 | 10               |          | 1 | 58804351     |
| 303                  | 3,2    | 2,2    | 30       | 60 | ▲▲▲▲           | Combi3 | 10               |          | 1 | 58804353     |
| 350                  | 3,5    | 2,5    | 30       | 72 | ▲▲▲▲           | Combi3 | 10               |          | 1 | 58804280     |

## HW KDF - Industry Plus

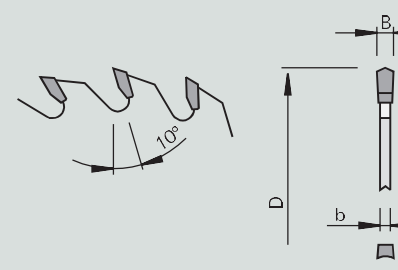
Formaat cirkelzaagblad HW - daktand-vlaktand met fase Duplovit

|   |  |   |   |  |
|---|--|---|---|--|
| Product   | Tekening   | Machine   | Toepassing  | Uitvoering   |
|  |  |  |  | LONG<br>LIFE<br>LOW<br>NOISE<br>3-0-1<br>DA-<br>F-FA<br>DU |

|  |   |   |                  |
|--|---|---|------------------|
| Machine / gebruiksaanwijzing   | Uitvoering  | Voordelen   | Informatie - Tip |
| <ul style="list-style-type: none"> <li>Tafelcirkelzagen</li> <li>Vertikale platenzagen</li> <li>Voor formaatsnedes in ruw en beplakt plaatmateriaal op basis van hout</li> </ul> | <ul style="list-style-type: none"> <li>Trilling- en geluiddempende ornamenten</li> <li>Extra spanningsseuven</li> <li>Tandvorm: daktand-vlaktand met fase Duplovit 'DA-F-FA DU'</li> <li>Snijmateriaal HW TC06</li> </ul> | <ul style="list-style-type: none"> <li>Extreem geluidsarm door vibratie- en geluiddempende ornamenten en speciale spanningsseuven</li> <li>Nette onderzijde ook zonder voorrits cirkelzaagblad</li> <li>Gereduceerde snijdruk</li> <li>Verlengde standtijd</li> <li>Verbeterde snijkwaliteit</li> </ul> |                  |

| Producteigenschappen |        |        |          |    |                |        | Bestelinformatie |          |   |              |
|----------------------|--------|--------|----------|----|----------------|--------|------------------|----------|---|--------------|
| Ø D [mm]             | B [mm] | b [mm] | Ø d [mm] | Z  | Snijkwaliteit* | NL**   | Spaanhoek [°]    | VE [St.] | V | Bestelnummer |
| 303                  | 3,2    | 2,2    | 30       | 60 | ▲▲▲▲           | Combi3 | 10               |          | 1 | 58804301     |

\* Snijkwaliteit ▲ Zeer grove snede, ▲▲ Grove snede, ▲▲▲ Fijne snede, ▲▲▲▲ Zeer fijne snede







\*\* Extra gaten: Combi1 komt overeen met 2/10/60 + 2/7/42 Combi2 komt overeen met 2/7/42 + 2/9/46 en 2/10/60 Combi3 = 2/10/60 + 2/9/46 + 2/9.5/46.5 + 2/7/42 Combi5 = 2/7/110 + 2/9/110 + 2/8.4/130 + 2/14/110 + 4/9/100 + 4/19/120 Combi7 = 2/9/110 + 2/10/80 + 2/11/85 + 2/11/115 + 2/11/148 + 2/14/100 + 2/14/125 + 2/19/120

Geschikte reduceerringen vindt u aan het einde van dit hoofdstuk

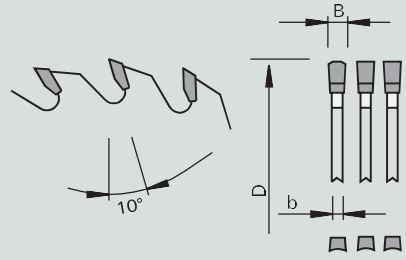
HW

## KDF - Industry Professionell

Formaat cirkelzaagblad HW - trapezium-vlaktand-vlaktand Duplovit

|  |  |   |
|--|--|---|
| <p>Product</p>  | <p>Tekening</p>  | <p>Machine</p>   <p>Toepassing</p>   <p>Uitvoering</p>  <p>3-0-1</p> <p>HW<br/><b>TC03</b></p> <p>TR-<br/>F-F<br/>DU</p> |
|--|--|---|

|   |  |   |                         |
|---|--|---|-------------------------|
| <p>Machine / gebruiksaanwijzing</p> <ul style="list-style-type: none"> <li>Tafelcirkelzagen</li> <li>Vertikale platenzagen</li> <li>Voor formaatsneden in (on)beplakte en kunststof beplakte plaatmaterialen</li> </ul> | <p>Uitvoering</p> <ul style="list-style-type: none"> <li>Trilling- en geluiddempende ornamenten</li> <li>Extra spanningsleuven</li> <li>Tandvorm: trapezium-vlaktand-vlaktand Duplovit 'TR-F-F DU'</li> <li>Snijmateriaal HW TC03</li> </ul> | <p>Voordelen</p> <ul style="list-style-type: none"> <li>Extreem geluidsarm door vibratie- en geluidsdempende ornamenten en speciale spanningsleuven</li> <li>Goede afwerking aan onderzijde ook zonder voorrits-zaagblad</li> <li>Beste snijkwaliteit door innovatieve groepenvertanding</li> </ul> | <p>Informatie - Tip</p> |
|---|--|---|-------------------------|





| Producteigenschappen |        |        |          |    |                |        |               | Bestelinformatie   |   |              |
|----------------------|--------|--------|----------|----|----------------|--------|---------------|--|---|--------------|
| Ø D [mm]             | B [mm] | b [mm] | Ø d [mm] | Z  | Snijkwaliteit* | NL**   | Spaanhoek [°] | VE [St.]   | V | Bestelnummer |
| 303                  | 3,5    | 2,5    | 30       | 60 | ▲▲▲▲           | Combi3 | 10            |  | 1 | 58804282     |

\* Snijkwaliteit ▲ Zeer grove snede, ▲▲ Grove snede, ▲▲▲ Fijne snede, ▲▲▲▲ Zeer fijne snede

\*\* Extra gaten: Combi1 komt overeen met 2/10/60 + 2/7/42 Combi2 komt overeen met 2/7/42 + 2/9/46 en 2/10/60 Combi3 = 2/10/60 + 2/9/46 + 2/9,5/46,5 + 2/7/42 Combi5 = 2/7/110 + 2/9/110 + 2/8,4/130 + 2/14/110 + 4/9/100 + 4/19/120 Combi7 = 2/9/110 + 2/10/80 + 2/11/85 + 2/11/115 + 2/11/148 + 2/14/100 + 2/14/125 + 2/19/120

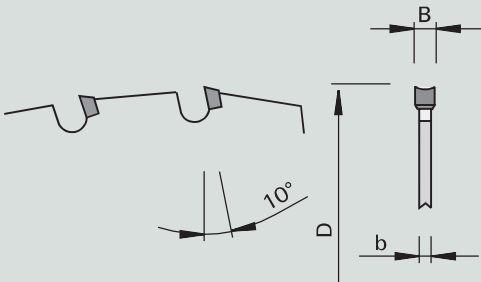
Geschikte reduceerringen vindt u aan het einde van dit hoofdstuk

**DP** **HRP - nn-System DP flex**  
 Formaat cirkelzaagblad DP -hollerugtand

|  |  |  |   |   |
|--|--|--|---|---|
| <p>Product</p>  | <p>Tekening</p>  | <p>Machine</p>  | <p>Toepassing</p>  | <p>Uitvoering</p>  <p>NO 2002</p> <p>3-0-1</p> <p>HR</p> |
|--|--|--|---|---|

|  |  |   |  |
|--|--|---|--|
| <p>Machine / gebruiksaanwijzing</p> <ul style="list-style-type: none"> <li>• Formaat- en tafelcirkelzagen</li> <li>• Verticale platenopdeelzagen</li> <li>• Afkortzagen</li> <li>• Voor precisiesnedes in alle gangbare platen op basis van hout</li> <li>• Voor langs- en dwarsnedes in massief hout</li> </ul> | <p>Uitvoering</p> <ul style="list-style-type: none"> <li>• Tandvorm: hollerugtand 'HR'</li> <li>• Snijmateriaal: DP</li> <li>• 2 keer naslijpbaar</li> <li>• Speciale snijgeometrie</li> <li>• Kleine spaanruimtes</li> <li>• Stamblad gecoat</li> </ul> | <p>Voordelen</p> <ul style="list-style-type: none"> <li>• Bijzonder prettig werken door nauwelijks waarneembare geluidsontwikkeling</li> <li>• Hoogste rendabiliteit en productiviteit door extreem lange standtijd</li> <li>• Verminderde snijdruk door holleruggeometrie</li> <li>• Coating beschermt tegen corrosie, hechting van vreemde materialen en vermindert de wrijving bij het stamblad</li> </ul> | <p>Informatie - Tip</p> <ul style="list-style-type: none"> <li>• Niet aanbevolen voor lengtesnedes in zacht hout en materiaal dikte van meer dan 40 mm</li> <li>• Braamvrije snedes kunnen alleen in combinatie met een geschikt voorrits cirkelzaagblad worden gegarandeerd</li> <li>• LET OP! Het spouwmes moet voor deze cirkelzaagbladen tussen de 2,0 en 2,4 mm dik zijn.</li> <li>• Leveringsomvang: spouwmes apart bestellen</li> </ul> |
|--|--|---|--|







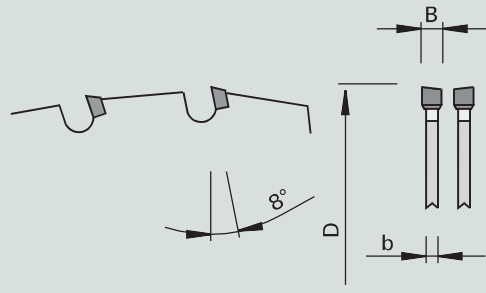

| Producteigenschappen |        |               |   |    |                |        |               | Bestelinformatie |   |              |
|----------------------|--------|---------------|---|----|----------------|--------|---------------|------------------|---|--------------|
| Ø D [mm]             | B [mm] | b [mm]        | Ø d [mm]                                | Z  | Snijkwaliteit* | NL**   | Spaanhoek [°] | VE [St.]         | V | Bestelnummer |
| 250                  | 2,5    | 2,0           | 30                                      | 50 | ▲▲▲            | Combi2 | 10            |                  | 1 | 58459455     |
| 303                  | 2,5    | 2,0           | 30                                      | 60 | ▲▲▲            | Combi2 | 10            |                  | 1 | 58459439     |
| 350                  | 2,5    | 2,0           | 30                                      | 72 | ▲▲▲            | Combi2 | 10            |                  | 1 | 58459446     |
| Toebehoren           |        | Afmeting [mm] |   |    |                |        |               | VE [St.]         | V | Bestelnummer |
| Spouwmes             |        | 2,25          | Altendorf F45                           |    |                |        |               | 1                |   | 192425       |
| Spouwmes             |        | 2,25          | HOLZ-HER Vertikal                       |    |                |        |               | 1                |   | 192429       |
| Spouwmes             |        | 2,25          | Striebig Standard III Control Evolution |    |                |        |               | 1                |   | 192430       |
| Spouwmes             |        | 2,25          | Striebig Standard Eco                   |    |                |        |               | 1                |   | 192431       |
| Spouwmes             |        | 2,25          | Putsch                                  |    |                |        |               | 1                |   | 192457       |
| Spouwmes             |        | 2,25          | Martin T60A                             |    |                |        |               | 1                |   | 192535       |
| Spouwmes             |        | 2,2           | Elcon                                   |    |                |        |               | 1                | s | 80384841     |

\* Snijkwaliteit ▲ Zeer grove snede, ▲▲ Grove snede, ▲▲▲ Fijne snede, ▲▲▲▲ Zeer fijne snede

\*\* Extra gaten: Combi1 komt overeen met 2/10/60 + 2/7/42 Combi2 komt overeen met 2/7/42 + 2/9/46 en 2/10/60 Combi3 = 2/10/60 + 2/9/46 + 2/9.5/46.5 + 2/7/42 Combi5 = 2/7/110 + 2/9/110 + 2/8.4/130 + 2/14/110 + 4/9/100 + 4/19/120 Combi7 = 2/9/110 + 2/10/80 + 2/11/85 + 2/11/115 + 2/11/148 + 2/14/100 + 2/14/125 + 2/19/120

Geschikte reduceerringen vindt u aan het einde van dit hoofdstuk

**DP** **RSK - nn-System DP flex**  
Voorrits cirkelzaagblad DP - wisseltand

|  |  |  |   |  |
|--|--|--|---|--|
| <p>Product</p>  | <p>Tekening</p>  | <p>Machine</p>   | <p>Toepassing</p>    | <p>Uitvoering</p>   <p>3-0-1</p> <p>WS</p> |
|--|--|--|---|--|

|  |  |  |                         |
|--|--|--|-------------------------|
| <p>Machine / gebruiksaanwijzing</p> <ul style="list-style-type: none"> <li>• Formaat- en tafelcirkelzagen</li> <li>• Voor precisiesnedes in alle gangbare platen op basis van hout</li> <li>• Voor langs- en dwarsnedes in massief hout</li> </ul> | <p>Uitvoering</p> <ul style="list-style-type: none"> <li>• Tandvorm: wisseltand 'WS'</li> <li>• Snijmateriaal: DP</li> <li>• 2 keer naslijpbaar</li> <li>• Speciale snijgeometrie</li> <li>• Kleine spaanruimtes</li> <li>• Stamblad gecoat</li> </ul> | <p>Voordelen</p> <ul style="list-style-type: none"> <li>• Bijzonder prettig werken door nauwelijks waarneembare geluidsontwikkeling</li> <li>• Hoogste rendabiliteit en productiviteit door extreem lange standtijd</li> <li>• Coating beschermt tegen corrosie, hechting van vreemde materialen en vermindert de wrijving bij het stamblad</li> </ul> | <p>Informatie - Tip</p> |
|--|--|--|-------------------------|

| Producteigenschappen |        |        |          |    |                |               | Bestelinformatie |          |   |                      |
|----------------------|--------|--------|----------|----|----------------|---------------|------------------|----------|---|----------------------|
| Ø D [mm]             | B [mm] | b [mm] | Ø d [mm] | Z  | Snijkwaliteit* | Spaanhoek [°] |                  | VE [St.] | V | Bestelnummer         |
| 120                  | 2,6    | 2,0    | 20       | 24 | ▲▲▲▲           | 5             |                  | 1        |   | 58459419             |
| 120                  | 2,6    | 2,0    | 22       | 24 | ▲▲▲▲           | 5             |                  | 1        |   | 58459365             |
| 125                  | 2,6    | 2,0    | 20       | 24 | ▲▲▲▲           | 5             |                  | 1        |   | 58459436             |
| 180                  | 2,6    | 2,0    | 22       | 36 | ▲▲▲▲           | 5             | Altendorf        | 1        |   | 58192964 <b>NEUW</b> |





\* Snijkwaliteit ▲ Zeer grove snede, ▲▲ Grove snede, ▲▲▲ Fijne snede, ▲▲▲▲ Zeer fijne snede

\*\* Extra gaten: **Combi1** komt overeen met 2/10/60 + 2/7/42 **Combi2** komt overeen met 2/7/42 + 2/9/46 en 2/10/60 **Combi3** = 2/10/60 + 2/9/46 + 2/9,5/46,5 + 2/7/42 **Combi5** = 2/7/110 + 2/9/110 + 2/8,4/130 + 2/14/110 + 4/9/100 + 4/19/120 **Combi7** = 2/9/110 + 2/10/80 + 2/11/85 + 2/11/115 + 2/11/148 + 2/14/100 + 2/14/125 + 2/19/120

Geschikte **reduceerringen** vindt u aan het einde van dit hoofdstuk

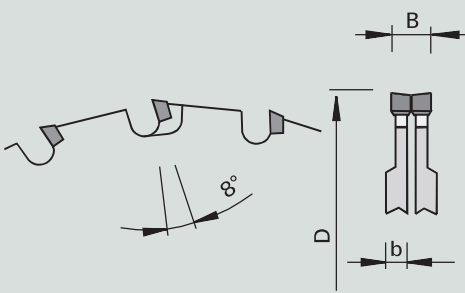

**DP RSK - nn-systeem DP flex - verstelbaar**  
**Voorrits cirkelzaagblad DP 'ES' - verstelbaar**

|  |  |  |   |  |
|--|--|--|---|--|
| <p>Product</p>  | <p>Tekening</p>  | <p>Machine</p>  | <p>Toepassing</p>  | <p>Uitvoering</p>   <p>3-0-1</p> <p>ES</p> |
|--|--|--|---|--|

|   |  |   |  |
|---|--|---|--|
| <p>Machine / gebruiksaanwijzing</p> <ul style="list-style-type: none"> <li>• Formaat- en tafelcirkelzagen</li> <li>• Voor het braamvrij voorritsen van diverse gecoate plaatmaterialen op basis van hout</li> </ul> | <p>Uitvoering</p> <ul style="list-style-type: none"> <li>• Tandvorm: wisseltand 'WS'</li> <li>• Snijmateriaal: DP</li> <li>• 2 keer naslijpbaar</li> <li>• Kleine spaanruimtes</li> <li>• Stamblad gecoat</li> </ul> | <p>Voordelen</p> <ul style="list-style-type: none"> <li>• Nauwelijks waarneembare geluidontwikkeling</li> <li>• Hoogste rendabiliteit en productiviteit door extreem lange standtijden</li> <li>• Coating beschermt tegen corrosie, hechting van vreemde materialen en vermindert de wrijving bij het stamblad</li> </ul> | <p>Informatie - Tip</p> <ul style="list-style-type: none"> <li>• Altendorf RAPIDO / verstelbaar</li> </ul> |
|---|--|---|--|

| Producteigenschappen |         |        |          |       |                |               | Bestelinformatie  |          |   |              |
|----------------------|---------|--------|----------|-------|----------------|---------------|---|----------|---|--------------|
| Ø D [mm]             | B [mm]  | b [mm] | Ø d [mm] | Z     | Snijkwaliteit* | Spaanhoek [°] |   | VE [St.] | V | Bestelnummer |
| 120                  | 2,4-3,2 | 2,2    | 50       | 12+12 | ▲▲▲▲           | 8             |  | 1        |   | 58459461     |

\* Snijkwaliteit ▲ Zeer grove snede, ▲▲ Grove snede, ▲▲▲ Fijne snede, ▲▲▲▲ Zeer fijne snede

\*\* Extra gaten: Combi1 komt overeen met 2/10/60 + 2/7/42 Combi2 komt overeen met 2/7/42 + 2/9/46 en 2/10/60 Combi3 = 2/10/60 + 2/9/46 + 2/9.5/46.5 + 2/7/42 Combi5 = 2/7/110 + 2/9/110 + 2/8.4/130 + 2/14/110 + 4/9/100 + 4/19/120 Combi7 = 2/9/110 + 2/10/80 + 2/11/85 + 2/11/115 + 2/11/148 + 2/14/100 + 2/14/125 + 2/19/120

Geschikte reduceerringen vindt u aan het einde van dit hoofdstuk

## Toewijzing van voorrits- en hoofdcirkelzaagbladen voor platenopdeel zaagmachines

| Machinentyp |  |  | ØD | B | b | Ød | Z | Tandvorm | Spaanhoek | Stehle<br>NL | Stehle |
|-------------|--|--|----|---|---|----|---|----------|-----------|--------------|--------|
|-------------|--|--|----|---|---|----|---|----------|-----------|--------------|--------|

| SCM - Gabbiani    |               |    |     |     |     |    |    |         |    |        |          |
|-------------------|---------------|----|-----|-----|-----|----|----|---------|----|--------|----------|
| Galaxy 115        | Hoofdzaagblad | HW | 400 | 4,4 | 3,2 | 80 | 72 | TR-F    | 15 | Combi5 | 58807809 |
|                   | Hoofdzaagblad | DP | 400 | 4,4 | 3,2 | 80 | 72 | TR-F-FA | 15 | Combi5 | 50750134 |
| Galaxy3 110, 110A | Hoofdzaagblad | HW | 400 | 4,4 | 3,2 | 80 | 72 | TR-F    | 15 | Combi5 | 58807809 |
|                   | Hoofdzaagblad | DP | 400 | 4,4 | 3,2 | 80 | 72 | TR-F-FA | 15 | Combi5 | 50750134 |
| Galaxy3 130, 130A | Hoofdzaagblad | HW | 430 | 4,4 | 3,2 | 80 | 72 | TR-F    | 15 | Combi5 | 58806479 |
| Galaxy3 145       | Hoofdzaagblad | HW | 430 | 4,4 | 3,2 | 80 | 72 | TR-F    | 15 | Combi5 | 58806479 |

| Giben                          |                         |    |     |         |     |    |    |         |    |                    |          |
|--------------------------------|-------------------------|----|-----|---------|-----|----|----|---------|----|--------------------|----------|
| G 2000 Starmatic               | Hoofdzaagblad           | HW | 400 | 4,4     | 3,2 | 75 | 72 | TR-F    | 15 | 4/15/105 + 2/7/110 | 58806071 |
|                                | Hoofdzaagblad           | DP | 400 | 4,4     | 3,2 | 75 | 72 | TR-F-FA | 15 | 4/15/105 + 2/7/110 | 50750133 |
| MK, Gamma, N, ST,<br>SE, Trend | Hoofdzaagblad           | HW | 355 | 4,4     | 3,0 | 75 | 72 | TR-F    | 10 | 4/15/105           | 58807888 |
|                                | Voorrits cirkelzaagblad | HW | 125 | 4,3-5,5 | 3,2 | 45 | 24 | CON     | 0  |                    |          |
| Prismatic 101                  | Hoofdzaagblad           | HW | 400 | 4,4     | 3,2 | 75 | 72 | TR-F    | 15 | 4/15/105 + 2/7/110 | 58806071 |
|                                | Hoofdzaagblad           | DP | 400 | 4,4     | 3,2 | 75 | 72 | TR-F-FA | 15 | 4/15/105 + 2/7/110 | 50750133 |
|                                | Voorrits cirkelzaagblad | DP | 160 | 4,4-5,2 | 3,2 | 45 | 30 | KO-F    | 5  | 3/11/70            | 50750121 |
| Prismatic 201                  | Hoofdzaagblad           | HW | 400 | 4,4     | 3,2 | 75 | 72 | TR-F    | 15 | 4/15/105 + 2/7/110 | 58806071 |
|                                | Hoofdzaagblad           | DP | 400 | 4,4     | 3,2 | 75 | 72 | TR-F-FA | 15 | 4/15/105 + 2/7/110 | 50750133 |

| Haisung Woodworking Machinery |               |    |     |     |     |    |    |         |    |                    |          |
|-------------------------------|---------------|----|-----|-----|-----|----|----|---------|----|--------------------|----------|
| HSWMMC-<br>2600III/3200III    | Hoofdzaagblad | HW | 400 | 4,4 | 3,2 | 75 | 72 | TR-F    | 15 | 4/15/105 + 2/7/110 | 58806071 |
|                               | Hoofdzaagblad | DP | 400 | 4,4 | 3,2 | 75 | 72 | TR-F-FA | 15 | 4/15/105 + 2/7/110 | 50750133 |

| Hansol Maschine                  |               |    |     |     |     |    |    |         |    |                    |          |
|----------------------------------|---------------|----|-----|-----|-----|----|----|---------|----|--------------------|----------|
| NCNC-<br>2600H10/2600H13/3660H13 | Hoofdzaagblad | HW | 400 | 4,4 | 3,2 | 75 | 72 | TR-F    | 15 | 4/15/105 + 2/7/110 | 58806071 |
|                                  | Hoofdzaagblad | DP | 400 | 4,4 | 3,2 | 75 | 72 | TR-F-FA | 15 | 4/15/105 + 2/7/110 | 50750133 |

| Holz-Her  |                         |    |     |         |     |    |    |         |    |                  |          |
|-----------|-------------------------|----|-----|---------|-----|----|----|---------|----|------------------|----------|
| Cut 110   | Hoofdzaagblad           | HW | 400 | 4,4     | 3,2 | 30 | 72 | TR-F    | 15 | Combi3 + 2/13/94 | 58806069 |
|           | Hoofdzaagblad           | DP | 400 | 4,4     | 3,2 | 30 | 72 | TR-F-FA | 15 | Combi3 + 2/13/94 | 50750132 |
| Cut 85 82 | Hoofdzaagblad           | HW | 350 | 4,4     | 3,0 | 30 | 72 | TR-F    | 10 | Combi3 + 2/13/94 | 58808803 |
|           | Hoofdzaagblad           | DP | 350 | 4,4     | 3,2 | 30 | 72 | TR-F-FA | 10 | Combi 1          | 50750128 |
|           | Hoofdzaagblad           | DP | 350 | 4,4     | 3,0 | 30 | 72 | TR-F-FA | 10 | Combi2 + 2/13/94 | 50750129 |
|           | Voorrits cirkelzaagblad | HW | 180 | 4,4-5,2 | 3,2 | 30 | 30 | KO-F    | 8  | 2/10/60          | 58807858 |
|           | Voorrits cirkelzaagblad | DP | 180 | 4,4-5,2 | 3,2 | 30 | 30 | KO-F    | 5  | 2/10/60          | 50750122 |

\* Snijkwaliteit ▲ Zeer grove snede, ▲▲ Grove snede, ▲▲▲ Fijne snede, ▲▲▲▲ Zeer fijne snede

\*\* Extra gaten: Combi1 komt overeen met 2/10/60 + 2/7/42 Combi2 komt overeen met 2/7/42 + 2/9/46 en 2/10/60 Combi3 = 2/10/60 + 2/9/46 + 2/9,5/46,5 + 2/7/42 Combi5 = 2/7/110 + 2/9/110 + 2/8,4/130 + 2/14/110 + 4/9/100 + 4/19/120 Combi7 = 2/9/110 + 2/10/80 + 2/11/85 + 2/11/115 + 2/11/148 + 2/14/100 + 2/14/125 + 2/19/120

Geschikte reduceerringen vindt u aan het einde van dit hoofdstuk

| Machinentyp              |                         |    | ØD  | B         | b   | Ød | Z  | Tandvorm | Spaanhoek | Stehle<br>NL        | Stehle   |
|--------------------------|-------------------------|----|-----|-----------|-----|----|----|----------|-----------|---------------------|----------|
| <b>Holzma</b>            |                         |    |     |           |     |    |    |          |           |                     |          |
| 22                       | Voorrits cirkelzaagblad | HW | 200 | 4,85-5,65 | 3,5 | 45 | 36 | KO-F     | 8         |                     | 58806134 |
|                          | Voorrits cirkelzaagblad | DP | 200 | 4,8-5,6   | 3,5 | 45 | 30 | KO-F     | 5         |                     | 50750127 |
| HPP180                   | Hoofdzaagblad           | HW | 380 | 4,8       | 3,5 | 60 | 72 | TR-F     | 15        | Combi7              | 58806065 |
|                          | Hoofdzaagblad           | DP | 380 | 4,8       | 3,5 | 60 | 72 | TR-F-FA  | 10        | 2/14/100 + 2/14/125 | 50750131 |
|                          | Hoofdzaagblad           | DP | 380 | 4,4       | 3,2 | 60 | 72 | TR-F-FA  | 10        | 2/14/100 + 2/14/125 | 50750130 |
|                          | Voorrits cirkelzaagblad | HW | 180 | 4,4-5,2   | 3,2 | 45 | 36 | KO-F     | 8         |                     | 58803104 |
|                          | Voorrits cirkelzaagblad | HW | 200 | 4,4-5,2   | 3,5 | 45 | 36 | KO-F     | 8         |                     | 58803074 |
|                          | Voorrits cirkelzaagblad | DP | 180 | 4,4-5,2   | 3,2 | 45 | 30 | KO-F     | 5         |                     | 50750123 |
| HPP350                   | Hoofdzaagblad           | HW | 350 | 4,4       | 3,2 | 60 | 72 | TR-F     | 10        | Combi7              | 58807955 |
|                          | Voorrits cirkelzaagblad | HW | 180 | 4,4-5,2   | 3,2 | 45 | 36 | KO-F     | 8         |                     | 58803104 |
|                          | Voorrits cirkelzaagblad | DP | 180 | 4,4-5,2   | 3,2 | 45 | 30 | KO-F     | 5         |                     | 50750123 |
| HPP380, 82               | Hoofdzaagblad           | HW | 380 | 4,8       | 3,5 | 60 | 72 | TR-F     | 15        | Combi7              | 58806065 |
|                          | Hoofdzaagblad           | DP | 380 | 4,8       | 3,5 | 60 | 72 | TR-F-FA  | 10        | 2/14/100 + 2/14/125 | 50750131 |
|                          | Hoofdzaagblad           | DP | 380 | 4,4       | 3,2 | 60 | 72 | TR-F-FA  | 10        | 2/14/100 + 2/14/125 | 50750130 |
|                          | Voorrits cirkelzaagblad | HW | 180 | 4,4-5,2   | 3,2 | 45 | 36 | KO-F     | 8         |                     | 58803104 |
|                          | Voorrits cirkelzaagblad | HW | 180 | 4,85-5,65 | 3,5 | 45 | 36 | KO-F     | 8         |                     | 58807862 |
|                          | Voorrits cirkelzaagblad | DP | 180 | 4,4-5,2   | 3,2 | 45 | 30 | KO-F     | 5         |                     | 50750123 |
|                          | Voorrits cirkelzaagblad | DP | 180 | 4,8-5,6   | 3,5 | 45 | 30 | KO-F     | 5         |                     | 50750124 |
| HPL410                   | Hoofdzaagblad           | HW | 420 | 4,8       | 3,5 | 60 | 72 | TR-F     | 15        | Combi7              | 58807956 |
|                          | Hoofdzaagblad           | DP | 420 | 4,8       | 3,5 | 60 | 60 | TR-F-FA  | 15        | 2/10/80 + 2/14/125  | 50750135 |
|                          | Voorrits cirkelzaagblad | HW | 180 | 4,85-5,65 | 3,5 | 45 | 36 | KO-F     | 8         |                     | 58807862 |
|                          | Voorrits cirkelzaagblad | DP | 180 | 4,8-5,6   | 3,5 | 45 | 30 | KO-F     | 5         |                     | 50750124 |
| HPL550                   | Voorrits cirkelzaagblad | HW | 200 | 4,85-5,65 | 3,5 | 45 | 36 | KO-F     | 8         |                     | 58806134 |
|                          | Voorrits cirkelzaagblad | DP | 200 | 4,8-5,6   | 3,5 | 45 | 30 | KO-F     | 5         |                     | 50750127 |
| HPL570                   | Voorrits cirkelzaagblad | HW | 200 | 4,85-5,65 | 3,5 | 45 | 36 | KO-F     | 8         |                     | 58806134 |
|                          | Voorrits cirkelzaagblad | DP | 200 | 4,8-5,6   | 3,5 | 45 | 30 | KO-F     | 5         |                     | 50750127 |
| HPP230,250 (vor 06/2014) | Hoofdzaagblad           | HW | 350 | 4,4       | 3,2 | 60 | 72 | TR-F     | 10        | Combi7              | 58807955 |
|                          | Voorrits cirkelzaagblad | HW | 200 | 4,4-5,2   | 3,5 | 45 | 36 | KO-F     | 8         |                     | 58803074 |
|                          | Voorrits cirkelzaagblad | HW | 180 | 4,4-5,2   | 3,2 | 45 | 36 | KO-F     | 8         |                     | 58803104 |
|                          | Voorrits cirkelzaagblad | DP | 180 | 4,4-5,2   | 3,2 | 45 | 30 | KO-F     | 5         |                     | 50750123 |
| HPP130                   | Voorrits cirkelzaagblad | HW | 180 | 4,4-5,2   | 3,2 | 45 | 36 | KO-F     | 8         |                     | 58803104 |
|                          | Voorrits cirkelzaagblad | DP | 180 | 4,4-5,2   | 3,2 | 45 | 30 | KO-F     | 5         |                     | 50750123 |
| HPP430,510,11            | Hoofdzaagblad           | HW | 450 | 4,8       | 3,5 | 60 | 72 | TR-F     | 15        | Combi7              | 58807817 |
|                          | Hoofdzaagblad           | DP | 450 | 4,8       | 3,5 | 60 | 72 | TR-F-FA  | 15        | Combi7              | 50750136 |
|                          | Voorrits cirkelzaagblad | HW | 180 | 4,85-5,65 | 3,5 | 45 | 36 | KO-F     | 8         |                     | 58807862 |
|                          | Voorrits cirkelzaagblad | DP | 180 | 4,8-5,6   | 3,5 | 45 | 30 | KO-F     | 5         |                     | 50750124 |

|              |                         |    |     |         |     |    |    |         |    |                    |          |
|--------------|-------------------------|----|-----|---------|-----|----|----|---------|----|--------------------|----------|
| <b>Homag</b> |                         |    |     |         |     |    |    |         |    |                    |          |
| CH 04        | Voorrits cirkelzaagblad | HW | 180 | 4,4-5,2 | 3,2 | 45 | 36 | KO-F    | 8  |                    | 58803104 |
|              | Voorrits cirkelzaagblad | DP | 180 | 4,4-5,2 | 3,2 | 45 | 30 | KO-F    | 5  |                    | 50750123 |
| CH 08/12     | Hoofdzaagblad           | HW | 400 | 4,4     | 3,2 | 75 | 72 | TR-F    | 15 | 4/15/105 + 2/7/110 | 58806071 |
|              | Hoofdzaagblad           | DP | 400 | 4,4     | 3,2 | 75 | 72 | TR-F-FA | 15 | 4/15/105 + 2/7/110 | 50750133 |

|                      |                         |    |     |         |     |    |    |         |    |                    |          |
|----------------------|-------------------------|----|-----|---------|-----|----|----|---------|----|--------------------|----------|
| <b>Hyundai Sangi</b> |                         |    |     |         |     |    |    |         |    |                    |          |
| CNC 740SD/CNC-740LSD | Hoofdzaagblad           | HW | 400 | 4,4     | 3,2 | 75 | 72 | TR-F    | 15 | 4/15/105 + 2/7/110 | 58806071 |
|                      | Hoofdzaagblad           | DP | 400 | 4,4     | 3,2 | 75 | 72 | TR-F-FA | 15 | 4/15/105 + 2/7/110 | 50750133 |
|                      | Voorrits cirkelzaagblad | HW | 200 | 4,4-5,2 | 3,5 | 45 | 36 | KO-F    | 8  |                    | 58803074 |
|                      | Voorrits cirkelzaagblad | HW | 200 | 4,4-5,2 | 3,5 | 45 | 36 | KO-F    | 8  |                    | 58803074 |

|                |                         |    |     |         |     |    |    |         |    |                    |          |
|----------------|-------------------------|----|-----|---------|-----|----|----|---------|----|--------------------|----------|
| <b>KDT</b>     |                         |    |     |         |     |    |    |         |    |                    |          |
| KS-226, 232    | Hoofdzaagblad           | HW | 355 | 4,4     | 3,2 | 75 | 72 | TR-F    | 15 | 4/15/105           | 58808888 |
|                | Hoofdzaagblad           | HW | 400 | 4,4     | 3,2 | 75 | 72 | TR-F    | 15 | 4/15/105 + 2/7/110 | 58806071 |
|                | Hoofdzaagblad           | DP | 400 | 4,4     | 3,2 | 75 | 72 | TR-F-FA | 15 | 4/15/105 + 2/7/110 | 50750133 |
|                | Voorrits cirkelzaagblad | HW | 180 | 4,4-5,2 | 3,2 | 30 | 30 | KO-F    | 8  | 2/10/60            | 58807858 |
|                | Voorrits cirkelzaagblad | DP | 180 | 4,4-5,2 | 3,2 | 30 | 30 | KO-F    | 5  | 2/10/60            | 50750122 |
| KS-829P, 829CP | Hoofdzaagblad           | HW | 400 | 4,4     | 3,2 | 75 | 72 | TR-F    | 15 | 4/15/105 + 2/7/110 | 58806071 |
|                | Hoofdzaagblad           | DP | 400 | 4,4     | 3,2 | 75 | 72 | TR-F-FA | 15 | 4/15/105 + 2/7/110 | 50750133 |
| KS-823P, 832CP | Hoofdzaagblad           | HW | 400 | 4,4     | 3,2 | 75 | 72 | TR-F    | 15 | 4/15/105 + 2/7/110 | 58806071 |
|                | Hoofdzaagblad           | DP | 400 | 4,4     | 3,2 | 75 | 72 | TR-F-FA | 15 | 4/15/105 + 2/7/110 | 50750133 |
| KS-838CP       | Hoofdzaagblad           | HW | 400 | 4,4     | 3,2 | 75 | 72 | TR-F    | 15 | 4/15/105 + 2/7/110 | 58806071 |
|                | Hoofdzaagblad           | DP | 400 | 4,4     | 3,2 | 75 | 72 | TR-F-FA | 15 | 4/15/105 + 2/7/110 | 50750133 |

\* Snijkwaliteit ▲ Zeer grove snede, ▲▲ Grove snede, ▲▲▲ Fijne snede, ▲▲▲▲ Zeer fijne snede

\*\* Extra gaten: Combi1 komt overeen met 2/10/60 + 2/7/42 Combi2 komt overeen met 2/7/42 + 2/9/46 en 2/10/60 Combi3 = 2/10/60 + 2/9/46 + 2/9.5/46.5 + 2/7/42 Combi5 = 2/7/110 + 2/9/110 + 2/8.4/130 + 2/14/110 + 4/9/100 + 4/19/120 Combi7 = 2/9/110 + 2/10/80 + 2/11/85 + 2/11/115 + 2/11/148 + 2/14/100 + 2/14/125 + 2/19/120

Geschikte reduceerringen vindt u aan het einde van dit hoofdstuk

Cirkelzaagbladen/platenopdeelzaagbladen

| Machinentyp               |                         |    | ØD  | B         | b   | Ød | Z  | Tandvorm | Spaanhoek | Stehle<br>NL        | Stehle   |
|---------------------------|-------------------------|----|-----|-----------|-----|----|----|----------|-----------|---------------------|----------|
| <b>Nanxing</b>            |                         |    |     |           |     |    |    |          |           |                     |          |
| NZH3318, NPD380           | Hoofdzaagblad           | HW | 450 | 4,8       | 3,5 | 60 | 72 | TR-F     | 15        | Combi7              | 58807817 |
|                           | Hoofdzaagblad           | DP | 450 | 4,8       | 3,5 | 60 | 72 | TR-F-FA  | 15        | Combi7              | 50750136 |
|                           | Voorrits cirkelzaagblad | HW | 180 | 4,85-5,65 | 3,5 | 45 | 36 | KO-F     | 8         |                     | 58807862 |
|                           | Voorrits cirkelzaagblad | DP | 180 | 4,8-5,6   | 3,5 | 45 | 30 | KO-F     | 5         |                     | 50750124 |
| NPL330HG, NP330H, NP330HG | Hoofdzaagblad           | HW | 450 | 4,8       | 3,5 | 60 | 72 | TR-F     | 15        | Combi7              | 58807817 |
|                           | Hoofdzaagblad           | DP | 450 | 4,8       | 3,5 | 60 | 72 | TR-F-FA  | 15        | Combi7              | 50750136 |
|                           | Voorrits cirkelzaagblad | HW | 180 | 4,85-5,65 | 3,5 | 45 | 36 | KO-F     | 8         |                     | 58807862 |
|                           | Voorrits cirkelzaagblad | DP | 180 | 4,8-5,6   | 3,5 | 45 | 30 | KO-F     | 5         |                     | 50750124 |
| NPC330                    | Hoofdzaagblad           | HW | 380 | 4,8       | 3,5 | 60 | 72 | TR-F     | 15        | Combi7              | 58806065 |
|                           | Hoofdzaagblad           | DP | 380 | 4,8       | 3,5 | 60 | 72 | TR-F-FA  | 10        | 2/14/100 + 2/14/125 | 50750131 |
|                           | Hoofdzaagblad           | DP | 380 | 4,4       | 3,2 | 60 | 72 | TR-F-FA  | 10        | 2/14/100 + 2/14/125 | 50750130 |
|                           | Hoofdzaagblad           | HW | 350 | 4,4       | 3,2 | 60 | 72 | TR-F     | 10        | Combi7              | 58807955 |
|                           | Voorrits cirkelzaagblad | HW | 200 | 4,4-5,2   | 3,5 | 45 | 36 | KO-F     | 8         |                     | 58803074 |
| NP380FG, NP330FG, NP330F  | Voorrits cirkelzaagblad | HW | 180 | 4,4-5,2   | 3,2 | 30 | 30 | KO-F     | 8         | 2/10/60             | 58807858 |
|                           | Voorrits cirkelzaagblad | DP | 180 | 4,4-5,2   | 3,2 | 30 | 30 | KO-F     | 5         | 2/10/60             | 50750122 |
| NP280FG, NP280F           | Hoofdzaagblad           | HW | 350 | 4,4       | 3,2 | 60 | 72 | TR-F     | 10        | Combi7              | 58807955 |
|                           | Voorrits cirkelzaagblad | HW | 180 | 4,4-5,2   | 3,2 | 30 | 30 | KO-F     | 8         | 2/10/60             | 58807858 |
|                           | Voorrits cirkelzaagblad | DP | 180 | 4,4-5,2   | 3,2 | 30 | 30 | KO-F     | 5         | 2/10/60             | 50750122 |

|                              |                         |    |     |         |     |    |    |         |    |                  |          |
|------------------------------|-------------------------|----|-----|---------|-----|----|----|---------|----|------------------|----------|
| <b>Panhans</b>               |                         |    |     |         |     |    |    |         |    |                  |          |
| 693/SH 110                   | Hoofdzaagblad           | HW | 400 | 4,4     | 3,2 | 30 | 72 | TR-F    | 15 | Combi3 + 2/13/94 | 58806069 |
|                              | Hoofdzaagblad           | DP | 400 | 4,4     | 3,2 | 30 | 72 | TR-F-FA | 15 | Combi3 + 2/13/94 | 50750132 |
|                              | Voorrits cirkelzaagblad | HW | 180 | 4,4-5,2 | 3,2 | 30 | 30 | KO-F    | 8  | 2/10/60          | 58807858 |
|                              | Voorrits cirkelzaagblad | DP | 180 | 4,4-5,2 | 3,2 | 30 | 30 | KO-F    | 5  | 2/10/60          | 50750122 |
| Euro 10 SF                   | Hoofdzaagblad           | HW | 300 | 4,4     | 3   | 30 | 60 | TR-F    | 10 | Combi3           | 58806053 |
| Euro 12 SF                   | Hoofdzaagblad           | HW | 350 | 4,4     | 3,0 | 30 | 72 | TR-F    | 10 | Combi3 + 2/13/94 | 58808803 |
|                              | Hoofdzaagblad           | DP | 350 | 4,4     | 3,2 | 30 | 72 | TR-F-FA | 10 | Combi 1          | 50750128 |
|                              | Hoofdzaagblad           | DP | 350 | 4,4     | 3,0 | 30 | 72 | TR-F-FA | 10 | Combi2 + 2/13/94 | 50750129 |
| Euro 12,30                   | Hoofdzaagblad           | HW | 350 | 4,4     | 3,0 | 30 | 72 | TR-F    | 10 | Combi3 + 2/13/94 | 58808803 |
|                              | Hoofdzaagblad           | DP | 350 | 4,4     | 3,2 | 30 | 72 | TR-F-FA | 10 | Combi 1          | 50750128 |
|                              | Hoofdzaagblad           | DP | 350 | 4,4     | 3,0 | 30 | 72 | TR-F-FA | 10 | Combi2 + 2/13/94 | 50750129 |
|                              | Voorrits cirkelzaagblad | HW | 180 | 4,4-5,2 | 3,2 | 30 | 30 | KO-F    | 8  | 2/10/60          | 58807858 |
|                              | Voorrits cirkelzaagblad | DP | 180 | 4,4-5,2 | 3,2 | 30 | 30 | KO-F    | 5  | 2/10/60          | 50750122 |
| Euro 32                      | Voorrits cirkelzaagblad | HW | 180 | 4,4-5,2 | 3,2 | 30 | 30 | KO-F    | 8  | 2/10/60          | 58807858 |
|                              | Voorrits cirkelzaagblad | DP | 180 | 4,4-5,2 | 3,2 | 30 | 30 | KO-F    | 5  | 2/10/60          | 50750122 |
| Euro 5 (SF, Compact, Ecopan) | Hoofdzaagblad           | HW | 300 | 4,4     | 3   | 30 | 60 | TR-F    | 10 | Combi3           | 58806053 |
| Euro10, 693/SH 70            | Hoofdzaagblad           | HW | 300 | 4,4     | 3   | 30 | 60 | TR-F    | 10 | Combi3           | 58806053 |
|                              | Voorrits cirkelzaagblad | HW | 180 | 4,4-5,2 | 3,2 | 30 | 30 | KO-F    | 8  | 2/10/60          | 58807858 |
|                              | Voorrits cirkelzaagblad | DP | 180 | 4,4-5,2 | 3,2 | 30 | 30 | KO-F    | 5  | 2/10/60          | 50750122 |
| Eurostar 2 XL, Polystar      | Voorrits cirkelzaagblad | HW | 180 | 4,4-5,2 | 3,2 | 30 | 30 | KO-F    | 8  | 2/10/60          | 58807858 |
|                              | Voorrits cirkelzaagblad | DP | 180 | 4,4-5,2 | 3,2 | 30 | 30 | KO-F    | 5  | 2/10/60          | 50750122 |
| Eurostar 2 XXL               | Hoofdzaagblad           | HW | 400 | 4,4     | 3,2 | 30 | 72 | TR-F    | 15 | Combi3 + 2/13/94 | 58806069 |
|                              | Hoofdzaagblad           | DP | 400 | 4,4     | 3,2 | 30 | 72 | TR-F-FA | 15 | Combi3 + 2/13/94 | 50750132 |
|                              | Voorrits cirkelzaagblad | HW | 180 | 4,4-5,2 | 3,2 | 30 | 30 | KO-F    | 8  | 2/10/60          | 58807858 |
|                              | Voorrits cirkelzaagblad | DP | 180 | 4,4-5,2 | 3,2 | 30 | 30 | KO-F    | 5  | 2/10/60          | 50750122 |
| Polypan 47                   | Hoofdzaagblad           | HW | 350 | 4,4     | 3,0 | 30 | 72 | TR-F    | 10 | Combi3 + 2/13/94 | 58808803 |
|                              | Hoofdzaagblad           | DP | 350 | 4,4     | 3,2 | 30 | 72 | TR-F-FA | 10 | Combi 1          | 50750128 |
|                              | Hoofdzaagblad           | DP | 350 | 4,4     | 3,0 | 30 | 72 | TR-F-FA | 10 | Combi2 + 2/13/94 | 50750129 |
|                              | Voorrits cirkelzaagblad | HW | 180 | 4,4-5,2 | 3,2 | 30 | 30 | KO-F    | 8  | 2/10/60          | 58807858 |
|                              | Voorrits cirkelzaagblad | DP | 180 | 4,4-5,2 | 3,2 | 30 | 30 | KO-F    | 5  | 2/10/60          | 50750122 |
| S 45                         | Hoofdzaagblad           | HW | 300 | 4,4     | 3   | 30 | 60 | TR-F    | 10 | Combi3           | 58806053 |
|                              | Hoofdzaagblad           | HW | 350 | 4,4     | 3,0 | 30 | 72 | TR-F    | 10 | Combi3 + 2/13/94 | 58808803 |
|                              | Hoofdzaagblad           | DP | 350 | 4,4     | 3,2 | 30 | 72 | TR-F-FA | 10 | Combi 1          | 50750128 |
|                              | Hoofdzaagblad           | DP | 350 | 4,4     | 3,0 | 30 | 72 | TR-F-FA | 10 | Combi2 + 2/13/94 | 50750129 |
|                              | Voorrits cirkelzaagblad | HW | 180 | 4,4-5,2 | 3,2 | 30 | 30 | KO-F    | 8  | 2/10/60          | 58807858 |
|                              | Voorrits cirkelzaagblad | DP | 180 | 4,4-5,2 | 3,2 | 30 | 30 | KO-F    | 5  | 2/10/60          | 50750122 |

|               |               |    |     |     |     |    |    |         |    |                  |          |
|---------------|---------------|----|-----|-----|-----|----|----|---------|----|------------------|----------|
| <b>Scheer</b> |               |    |     |     |     |    |    |         |    |                  |          |
| PA 6000, 5500 | Hoofdzaagblad | HW | 350 | 4,4 | 3,0 | 30 | 72 | TR-F    | 10 | Combi3 + 2/13/94 | 58808803 |
|               | Hoofdzaagblad | DP | 350 | 4,4 | 3,2 | 30 | 72 | TR-F-FA | 10 | Combi 1          | 50750128 |
|               | Hoofdzaagblad | DP | 350 | 4,4 | 3,0 | 30 | 72 | TR-F-FA | 10 | Combi2 + 2/13/94 | 50750129 |

\* Snijkwaliteit ▲ Zeer grove snede, ▲▲ Grove snede, ▲▲▲ Fijne snede, ▲▲▲▲ Zeer fijne snede

\*\* Extra gaten: Combi1 komt overeen met 2/10/60 + 2/7/42 Combi2 komt overeen met 2/7/42 + 2/9/46 en 2/10/60 Combi3 = 2/10/60 + 2/9/46 + 2/9,5/46,5 + 2/7/42 Combi5 = 2/7/110 + 2/9/110 + 2/8,4/130 + 2/14/110 + 4/9/100 + 4/19/120 Combi7 = 2/9/110 + 2/10/80 + 2/11/85 + 2/11/115 + 2/11/148 + 2/14/100 + 2/14/125 + 2/19/120

Geschikte reduceerringen vindt u aan het einde van dit hoofdstuk

| Machinentyp             |                         |    | ØD  | B       | b   | Ød | Z  | Tandvorm | Spaanhoek | Stehle<br>NL      | Stehle   |
|-------------------------|-------------------------|----|-----|---------|-----|----|----|----------|-----------|-------------------|----------|
| <b>Schelling</b>        |                         |    |     |         |     |    |    |          |           |                   |          |
| FH4 (bis 06/2015)       | Hoofdzaagblad           | HW | 350 | 4,4     | 3,0 | 30 | 72 | TR-F     | 10        | Combi3 + 2/13/94  | 58808803 |
|                         | Hoofdzaagblad           | DP | 350 | 4,4     | 3,2 | 30 | 72 | TR-F-FA  | 10        | Combi 1           | 50750128 |
|                         | Hoofdzaagblad           | HW | 350 | 4,4     | 3,0 | 30 | 72 | TR-F-FA  | 10        | Combi2 + 2/13/94  | 50750129 |
| FH4 07/2015-07/2017     | Voorrits cirkelzaagblad | HW | 200 | 4,4-5,2 | 3,5 | 20 | 36 | KO-F     | 8         |                   | 58803073 |
|                         | Voorrits cirkelzaagblad | DP | 200 | 4,4-5,2 | 3,2 | 20 | 30 | KO-F     | 5         |                   | 50750125 |
|                         | Voorrits cirkelzaagblad | DP | 200 | 4,4-5,2 | 3,2 | 20 | 36 | KO-F     | 5         |                   | 50750147 |
| FH5                     | Hoofdzaagblad           | HW | 400 | 4,4     | 3,2 | 30 | 72 | TR-F     | 15        | Combi3 + 2/13/94  | 58806069 |
|                         | Hoofdzaagblad           | DP | 400 | 4,4     | 3,2 | 30 | 72 | TR-F-FA  | 15        | Combi3 + 2/13/94  | 50750132 |
|                         | Voorrits cirkelzaagblad | HW | 200 | 4,4-5,2 | 3,5 | 20 | 36 | KO-F     | 8         |                   | 58803073 |
|                         | Voorrits cirkelzaagblad | DP | 200 | 4,4-5,2 | 3,2 | 20 | 30 | KO-F     | 5         |                   | 50750125 |
|                         | Voorrits cirkelzaagblad | DP | 200 | 4,4-5,2 | 3,2 | 20 | 36 | KO-F     | 5         |                   | 50750147 |
| FH5 ab 07/2015          | Hoofdzaagblad           | HW | 400 | 4,4     | 3,2 | 30 | 72 | TR-F     | 15        | Combi3 + 2/13/94  | 58806069 |
|                         | Hoofdzaagblad           | DP | 400 | 4,4     | 3,2 | 30 | 72 | TR-F-FA  | 15        | Combi3 + 2/13/94  | 50750132 |
| FH6,AH6,CH6 bis 06/2015 | Hoofdzaagblad           | DP | 460 | 4,4     | 3,2 | 30 | 72 | TR-F-FA  | 15        | 3/13/94           | 50750146 |
|                         | Voorrits cirkelzaagblad | HW | 200 | 4,4-5,2 | 3,5 | 20 | 36 | KO-F     | 8         |                   | 58803073 |
|                         | Voorrits cirkelzaagblad | DP | 200 | 4,4-5,2 | 3,2 | 20 | 30 | KO-F     | 5         |                   | 50750125 |
|                         | Voorrits cirkelzaagblad | DP | 200 | 4,4-5,2 | 3,2 | 20 | 36 | KO-F     | 5         |                   | 50750147 |
| FH6,AH6CH6 ab 07/2015   | Hoofdzaagblad           | DP | 480 | 4,8     | 3,5 | 30 | 72 | TR-F-FA  | 15        | 2/10/60 + 2/13/94 | 50750139 |
| FK4 bis 06/2015         | Hoofdzaagblad           | HW | 350 | 4,4     | 3,0 | 30 | 72 | TR-F     | 10        | Combi3 + 2/13/94  | 58808803 |
|                         | Hoofdzaagblad           | DP | 350 | 4,4     | 3,2 | 30 | 72 | TR-F-FA  | 10        | Combi 1           | 50750128 |
|                         | Hoofdzaagblad           | DP | 350 | 4,4     | 3,0 | 30 | 72 | TR-F-FA  | 10        | Combi2 + 2/13/94  | 50750129 |
| FK4 ab 07/2015          | Hoofdzaagblad           | HW | 400 | 4,4     | 3,2 | 30 | 72 | TR-F     | 15        | Combi3 + 2/13/94  | 58806069 |
|                         | Hoofdzaagblad           | DP | 400 | 4,4     | 3,2 | 30 | 72 | TR-F-FA  | 15        | Combi3 + 2/13/94  | 50750132 |
|                         | Voorrits cirkelzaagblad | HW | 200 | 4,4-5,2 | 3,5 | 20 | 36 | KO-F     | 8         |                   | 58803073 |
|                         | Voorrits cirkelzaagblad | DP | 200 | 4,4-5,2 | 3,2 | 20 | 30 | KO-F     | 5         |                   | 50750125 |
|                         | Voorrits cirkelzaagblad | DP | 200 | 4,4-5,2 | 3,2 | 20 | 36 | KO-F     | 5         |                   | 50750147 |
| FK4 ab 07/2017          | Hoofdzaagblad           | HW | 400 | 4,4     | 3,2 | 30 | 72 | TR-F     | 15        | Combi3 + 2/13/94  | 58806069 |
|                         | Hoofdzaagblad           | DP | 400 | 4,4     | 3,2 | 30 | 72 | TR-F-FA  | 15        | Combi3 + 2/13/94  | 50750132 |
| FK6,FP6, FM6            | Hoofdzaagblad           | DP | 460 | 4,4     | 3,2 | 30 | 72 | TR-F-FA  | 15        | 3/13/94           | 50750146 |
|                         | Voorrits cirkelzaagblad | HW | 200 | 4,4-5,2 | 3,5 | 20 | 36 | KO-F     | 8         |                   | 58803073 |
|                         | Voorrits cirkelzaagblad | DP | 200 | 4,4-5,2 | 3,2 | 20 | 30 | KO-F     | 5         |                   | 50750125 |
|                         | Voorrits cirkelzaagblad | DP | 200 | 4,4-5,2 | 3,2 | 20 | 36 | KO-F     | 5         |                   | 50750147 |
| AL                      | Hoofdzaagblad           | HW | 450 | 4,4     | 3,2 | 30 | 72 | TR-F     | 15        | Combi3 + 2/13/94  | 58458789 |
|                         | Voorrits cirkelzaagblad | HW | 200 | 4,4-5,2 | 3,5 | 20 | 36 | KO-F     | 8         |                   | 58803073 |
|                         | Voorrits cirkelzaagblad | DP | 200 | 4,4-5,2 | 3,2 | 20 | 30 | KO-F     | 5         |                   | 50750125 |
|                         | Voorrits cirkelzaagblad | DP | 200 | 4,4-5,2 | 3,2 | 20 | 36 | KO-F     | 5         |                   | 50750147 |

|                           |                         |    |     |         |     |    |    |         |    |        |          |
|---------------------------|-------------------------|----|-----|---------|-----|----|----|---------|----|--------|----------|
| <b>SCM</b>                |                         |    |     |         |     |    |    |         |    |        |          |
| Prima 50                  | Voorrits cirkelzaagblad | HW | 160 | 4,4-5,2 | 3,2 | 55 | 36 | KO-F    | 8  | 3/7/66 | 58803072 |
| Prima 67                  | Voorrits cirkelzaagblad | HW | 160 | 4,4-5,2 | 3,2 | 55 | 36 | KO-F    | 8  | 3/7/66 | 58803072 |
| Impact 105 C/D, PlusC/D/P | Voorrits cirkelzaagblad | HW | 160 | 4,4-5,2 | 3,2 | 55 | 36 | KO-F    | 8  | 3/7/66 | 58803072 |
| Impact 85 K               | Voorrits cirkelzaagblad | HW | 160 | 4,4-5,2 | 3,2 | 55 | 36 | KO-F    | 8  | 3/7/66 | 58803072 |
| Impact 90                 | Voorrits cirkelzaagblad | HW | 160 | 4,4-5,2 | 3,2 | 55 | 36 | KO-F    | 8  | 3/7/66 | 58803072 |
| Impact 110                | Hoofdzaagblad           | HW | 400 | 4,4     | 3,2 | 80 | 72 | TR-F    | 15 | Combi5 | 58807809 |
|                           | Hoofdzaagblad           | DP | 400 | 4,4     | 3,2 | 80 | 72 | TR-F-FA | 15 | Combi5 | 50750134 |
|                           | Voorrits cirkelzaagblad | HW | 160 | 4,4-5,2 | 3,2 | 55 | 36 | KO-F    | 8  | 3/7/66 | 58803072 |

|  |                         |    |     |           |     |    |    |         |    |                      |          |
|--|-------------------------|----|-----|-----------|-----|----|----|---------|----|----------------------|----------|
| <b>Selco</b>                               |                         |    |     |           |     |    |    |         |    |                      |          |
| EB 70 (kit80) , 75 (Sector 430 Sector 450) | Hoofdzaagblad           | DP | 320 | 4,4       | 3,2 | 65 | 60 | TR-F-FA | 10 | 2/9/110              | 50750120 |
|  | Voorrits cirkelzaagblad | HW | 200 | 4,45-5,25 | 3,2 | 65 | 36 | KO-F    | 8  | 4/9/100 + 4/9/110    | 58806130 |
| WNZ  | Hoofdzaagblad           | DP | 320 | 4,4       | 3,2 | 65 | 60 | TR-F-FA | 10 | 2/9/110              | 50750120 |
|  | Voorrits cirkelzaagblad | HW | 200 | 4,45-5,25 | 3,2 | 65 | 36 | KO-F    | 8  | 4/9/100 + 4/9/110    | 58806130 |
| EB 70(L)                                   | Voorrits cirkelzaagblad | HW | 200 | 4,45-5,25 | 3,2 | 65 | 36 | KO-F    | 8  | 4/9/100 + 2/9/110    | 58806130 |
| EB 95, Sector 470,SK470                    | Voorrits cirkelzaagblad | HW | 200 | 4,45-5,25 | 3,2 | 65 | 36 | KO-F    | 8  | 4/9/100 + 2/9/110    | 58806130 |
| EB108, EB110, EB120                        | Hoofdzaagblad           | HW | 400 | 4,4       | 3,2 | 80 | 72 | TR-F    | 15 | Combi5               | 58807809 |
|  | Hoofdzaagblad           | DP | 400 | 4,4       | 3,2 | 80 | 72 | TR-F-FA | 15 | Combi5               | 50750134 |
|  | Voorrits cirkelzaagblad | HW | 200 | 4,45-5,25 | 3,2 | 65 | 36 | KO-F    | 8  | 4/9/100 + 4/9/110    | 58806130 |
| EB/EBT 120, WN125                          | Hoofdzaagblad           | HW | 430 | 4,4       | 3,2 | 80 | 72 | TR-F    | 15 | Combi5               | 58806479 |
|  | Voorrits cirkelzaagblad | HW | 200 | 4,45-5,25 | 3,2 | 65 | 36 | KO-F    | 8  | 4/9/100 + 4/9/110    | 58806130 |
| EB100                                      | Voorrits cirkelzaagblad | HW | 200 | 4,45-5,25 | 3,2 | 65 | 36 | KO-F    | 8  | 4/9/100 + 4/9/110    | 58806130 |
| WN 600/132, WN200                          | Hoofdzaagblad           | DP | 450 | 4,8       | 3,5 | 80 | 72 | TR-F-FA | 15 | 4/13/120 + 2/8,4/130 | 50750137 |
|  | Voorrits cirkelzaagblad | DP | 200 | 4,8-5,6   | 3,5 | 65 | 30 | KO-F    | 5  | 2/8,4/110            | 50750126 |
| WNA 600/162                                | Voorrits cirkelzaagblad | DP | 200 | 4,8-5,6   | 3,5 | 65 | 30 | KO-F    | 5  | 2/8,4/110            | 50750126 |
| WNA 600/145, WN 512                        | Voorrits cirkelzaagblad | DP | 200 | 4,8-5,6   | 3,5 | 65 | 30 | KO-F    | 5  | 2/8,4/110            | 50750126 |
| WN 610, WN 630 (PFS)                       | Voorrits cirkelzaagblad | HW | 200 | 4,45-5,25 | 3,2 | 65 | 36 | KO-F    | 8  | 4/9/100 + 4/9/110    | 58806130 |

\* Snijkwaliteit ▲ Zeer grove snede, ▲▲ Grove snede, ▲▲▲ Fijne snede, ▲▲▲▲ Zeer fijne snede



\*\* Extra gaten: Combi1 komt overeen met 2/10/60 + 2/7/42 Combi2 komt overeen met 2/7/42 + 2/9/46 en 2/10/60 Combi3 = 2/10/60 + 2/9/46 + 2/9,5/46,5 + 2/7/42 Combi5 = 2/7/110 + 2/9/110 + 2/8,4/130 + 2/14/110 + 4/9/100 + 4/19/120 Combi7 = 2/9/110 + 2/10/80 + 2/11/85 + 2/11/115 + 2/11/148 + 2/14/100 + 2/14/125 + 2/19/120

Geschikte reduceerringen vindt u aan het einde van dit hoofdstuk





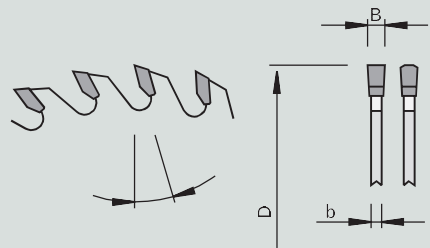







HW

TFP

Platenopdeel-cirkelzaagblad HW - Trapezium-vlaktand

|   |  |   |   |   |
|---|--|---|---|---|
| Product   | Tekening   | Machine   | Toepassing  | Uitvoering                              |
|  |  |  |  | 3-0-1<br>HW<br><b>TC04 plus</b><br>TR-F |

|  |  |   |  |
|--|--|---|--|
| Machine / gebruiksaanwijzing   | Uitvoering   | Voordelen   | Informatie - Tip   |
| <ul style="list-style-type: none"> <li>• Platenopdeelzagen</li> <li>• Voor formaatsneden in kunststof beplakte plaatmaterialen. Eventueel ook te zagen in pakketten</li> </ul> | <ul style="list-style-type: none"> <li>• Tandvorm: trapezium-vlaktand "TR-F"</li> <li>• Tandbezetting: HW TC04 plus</li> </ul> | <ul style="list-style-type: none"> <li>• Verbeterde snijkwaliteit door geoptimaliseerde tandgeometrie</li> <li>• Geluidsreductie door laser-ornamenten</li> </ul> | <ul style="list-style-type: none"> <li>• Bijzonder geschikt voor (kunststof) beplakte plaatmaterialen en multiplexen enkelvoudig of gestapeld</li> </ul> |

| Producteigenschappen |        |        |          |    |                |                    |               |   |   | Bestelinformatie |   |              |
|----------------------|--------|--------|----------|----|----------------|--------------------|---------------|---|---|------------------|---|--------------|
| Ø D [mm]             | B [mm] | b [mm] | Ø d [mm] | Z  | Snijkwaliteit* | NL**               | Spaanhoek [°] |   |   | VE [St.]         | V | Bestelnummer |
| 300                  | 4,4    | 3,0    | 30       | 60 | ▲▲▲            | Combi3             | 10            | Panhans                                   |    | 1                |   | 58806053     |
| 350                  | 4,4    | 3,0    | 30       | 72 | ▲▲▲            | Combi3 + 2/13/94   | 10            | SCM, Panhans, Mayer, Schelling, HOLZ-HER  |    | 1                |   | 58807803     |
| 350                  | 4,4    | 3,2    | 60       | 72 | ▲▲▲            | Combi7             | 10            | Holzma 72 HPP 350                         |  | 1                |   | 58807955     |
| 355                  | 4,4    | 3,0    | 75       | 72 | ▲▲▲            | 4/15/105           | 10            | Gibben                                    |  | 1                |   | 58807888     |
| 380                  | 4,8    | 3,5    | 60       | 72 | ▲▲▲            | Combi7             | 15            | Holzma                                    |  | 1                |   | 58806065     |
| 400                  | 4,4    | 3,2    | 30       | 72 | ▲▲▲            | Combi3 + 2/13/94   | 15            | Schelling, Mayer, Irion, Scheer, HOLZ-HER |  | 1                |   | 58806069     |
| 400                  | 4,4    | 3,2    | 75       | 72 | ▲▲▲            | 4/15/105 + 2/7/110 | 15            | Giben, Homag                              |  | 1                |   | 58806071     |
| 400                  | 4,4    | 3,2    | 80       | 72 | ▲▲▲            | Combi5             | 15            | Selco, Irion                              |  | 1                |   | 58807809     |
| 420                  | 4,8    | 3,5    | 60       | 72 | ▲▲▲            | Combi7             | 15            | Holzma                                    |  | 1                |   | 58807956     |
| 430                  | 4,4    | 3,2    | 80       | 72 | ▲▲▲            | Combi5             | 15            | Selco                                     |  | 1                |   | 58806479     |
| 450                  | 4,4    | 3,2    | 30       | 72 | ▲▲             | Combi3 + 2/13/94   | 15            | Irion, Schelling                          |  | 1                |   | 58458789     |
| 450                  | 4,8    | 3,5    | 60       | 72 | ▲▲▲            | Combi7             | 15            | Holzma                                    |  | 1                |   | 58807817     |

\* Snijkwaliteit ▲ Zeer grove snede, ▲▲ Grove snede, ▲▲▲ Fijne snede, ▲▲▲▲ Zeer fijne snede

\*\* Extra gaten: Combi1 komt overeen met 2/10/60 + 2/7/42 Combi2 komt overeen met 2/7/42 + 2/9/46 en 2/10/60 Combi3 = 2/10/60 + 2/9/46 + 2/9,5/46,5 + 2/7/42 Combi5 = 2/7/110 + 2/9/110 + 2/8,4/130 + 2/14/110 + 4/9/100 + 4/19/120 Combi7 = 2/9/110 + 2/10/80 + 2/11/85 + 2/11/115 + 2/11/148 + 2/14/100 + 2/14/125 + 2/19/120

Geschikte reduceerringen vindt u aan het einde van dit hoofdstuk

DP

TFP

Platenopdeelzaagbladen DP - trapezium-vlaktand met tweezijdige fase

Product



Tekening

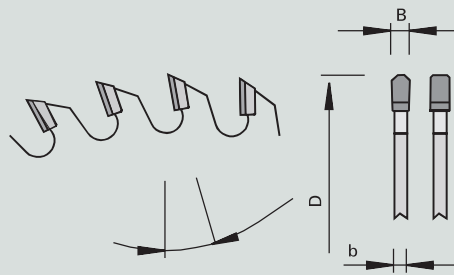

Machine



Toepassing



Uitvoering



3-0-1

TR-F-FA

Machine / gebruiksaanwijzing

- Platenopdeelzagen
- Voor formaatsneden in kunststof beplakte plaatmaterialen. Eventueel ook te zagen in pakketten
- Focus op universele inzetbaarheid

Uitvoering

- Trilling- en geluiddempende ornamenten
- Diamantsnijanten in gepolijste uitvoering
- Geoptimaliseerde snijgeometrie per tandvorm voor hoofdzagen en voorritszagen
- Tandvorm: trapezium-vlaktand met tweezijdige fase "TR-F-FA"
- Snijmateriaal DP
- Naslijpzone 4,5 mm

Voordelen

- Korte levertijden

Informatie - Tip

Producteigenschappen

Bestelinformatie

| Ø D [mm] | B [mm] | b [mm] | Ø d [mm] | Z  | Snijkwaliteit* | NL**                 | Spaanhoek [°] |  | VE [St.] | V | Bestelnummer |
|----------|--------|--------|----------|----|----------------|----------------------|---------------|--|----------|---|--------------|
| 320      | 4,4    | 3,2    | 65       | 60 | ▲▲▲            | 2/9/110              | 10            |  | 1        | o | 50750120     |
| 350      | 4,4    | 3,2    | 30       | 72 | ▲▲▲            | Combi 1              | 10            | SCM, Panhans, Mayer, Schelling, Scheer | 1        | o | 50750128     |
| 350      | 4,4    | 3,0    | 30       | 72 | ▲▲▲            | Combi2               | 10            | SCM, Panhans, Mayer, Schelling, Scheer | 1        | o | 50750129     |
| 380      | 4,4    | 3,2    | 60       | 72 | ▲▲▲            | 2/14/100 + 2/14/125  | 10            | Holzma                                 | 1        | o | 50750130     |
| 380      | 4,8    | 3,5    | 60       | 72 | ▲▲▲            | 2/14/100 + 2/14/125  | 10            | Holzma                                 | 1        | o | 50750131     |
| 400      | 4,4    | 3,2    | 30       | 72 | ▲▲▲            | Combi3 + 3/13/94     | 15            | Schelling, Mayer, Scheer, Irion        | 1        | o | 50750132     |
| 400      | 4,4    | 3,2    | 75       | 72 | ▲▲▲            | 4/15/105 + 2/7/110   | 15            | Giben, Homag                           | 1        | o | 50750133     |
| 400      | 4,4    | 3,2    | 80       | 72 | ▲▲▲            | Combi5               | 15            | Schelling, Mayer, Scheer, Irion        | 1        | o | 50750134     |
| 420      | 4,8    | 3,5    | 60       | 60 | ▲▲             | 2/10/80 + 2/14/125   | 15            | Holzma                                 | 1        | o | 50750135     |
| 450      | 4,8    | 3,5    | 60       | 72 | ▲▲▲            | Combi7               | 15            | Holzma                                 | 1        | o | 50750136     |
| 450      | 4,8    | 3,5    | 80       | 72 | ▲▲▲            | 4/19/120 + 2/8,4/130 | 15            | Selco                                  | 1        | o | 50750137     |
| 450      | 4,4    | 3,2    | 30       | 72 | ▲▲▲            |                      | 15            | Selco                                  | 1        | o | 50750138     |
| 460      | 4,4    | 3,2    | 30       | 72 | ▲▲▲            | 3/13/94              | 15            | Schelling                              | 1        | o | 50750146     |
| 480      | 4,8    | 3,5    | 30       | 72 | ▲▲▲            | 2/10/60 + 2/13/94    | 15            | Schelling                              | 1        | o | 50750139     |
| 480      | 4,8    | 3,5    | 60       | 72 | ▲▲▲            | 2/19/120             | 15            | Holzma                                 | 1        | o | 50750140     |

\* Snijkwaliteit ▲ Zeer grove snede, ▲▲ Grove snede, ▲▲▲ Fijne snede, ▲▲▲▲ Zeer fijne snede





\*\* Extra gaten: Combi1 komt overeen met 2/10/60 + 2/7/42 Combi2 komt overeen met 2/7/42 + 2/9/46 en 2/10/60 Combi3 = 2/10/60 + 2/9/46 + 2/9,5/46,5 + 2/7/42 Combi5 = 2/7/110 + 2/9/110 + 2/8,4/130 + 2/14/110 + 4/9/100 + 4/19/120 Combi7 = 2/9/110 + 2/10/80 + 2/11/85 + 2/11/115 + 2/11/148 + 2/14/100 + 2/14/125 + 2/19/120

Geschikte reduceerringen vindt u aan het einde van dit hoofdstuk

HW

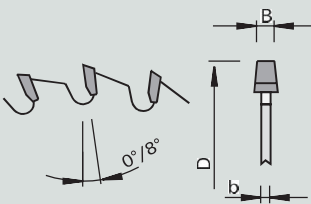
**RSK - nn-System**

Voorrits cirkelzaagblad HW - conische-vlaktand KO-F - nn-System

|  |   |  |   |  |
|--|---|--|---|--|
| <p>Product</p>  | <p>Tekening</p>  | <p>Machine</p>  | <p>Toepassing</p>  | <p>Uitvoering</p>  <p>3-0-1</p> <p>KO-F</p> |
|--|---|--|---|--|

|   |   |  |  |
|---|---|--|--|
| <p>Machine / gebruiksaanwijzing</p> <ul style="list-style-type: none"> <li>• Platenopdeelzagen met voorritsaggregaat</li> <li>• Voor het voorritsen van met kunststof beplakte plaatmaterialen</li> </ul> | <p>Uitvoering</p> <ul style="list-style-type: none"> <li>• Speciale NoNoise-spaanruimtegeometrie</li> <li>• Tandvorm: conische-vlaktand 'KO-F'</li> <li>• Snijmateriaal HW TC04 plus</li> </ul> | <p>Voordelen</p> <ul style="list-style-type: none"> <li>• Snel verstelbaar</li> <li>• Universeel inzetbaar</li> <li>• Beste snijkwaliteit door verbeterde loopnauwkeurigheid volgens schema</li> <li>• Vermindering van de ritsdiepte</li> <li>• Extreem geluidsarm</li> <li>• Geluidsreducering met ca. 6 dB(A) bij stationair draaien</li> <li>• Zeer goede snijkwaliteit bij alle standaardcoatings</li> <li>• Lange standtijden zorgen voor de nodige productiviteit en rendabiliteit</li> </ul> | <p>Informatie - Tip</p> <ul style="list-style-type: none"> <li>• Door hoogteverstelling van de as op snijbreedte van de hoofdzaag in te stellen</li> <li>• 1 mm ritsdiepte = 0,21 mm snijbreedte</li> <li>• Optimale voorrits-diepte 1,0 - 2,0 mm</li> </ul> |
|---|---|--|--|

| Producteigenschappen |           |        |          |    |                |                     |               | Bestelinformatie |          |              |  |
|----------------------|-----------|--------|----------|----|----------------|---------------------|---------------|------------------|----------|--------------|--|
| Ø D [mm]             | B [mm]    | b [mm] | Ø d [mm] | Z  | Snijkwaliteit* | NL**                | Spaanhoek [°] |                  | VE [St.] | Bestelnummer |  |
| 160                  | 4,4-5,2   | 3,2    | 55       | 36 | ▲▲▲▲           | 3/7/66              | 8             | Gabbiani         | 1        | 58803072     |  |
| 180                  | 4,4-5,2   | 3,2    | 30       | 30 | ▲▲▲▲           | 2/10/60             | 8             | Panhans          | 1        | 58807858     |  |
| 180                  | 4,4-5,2   | 3,2    | 45       | 36 | ▲▲▲▲           |                     | 8             | Holzma           | 1        | 58803104     |  |
| 180                  | 4,85-5,65 | 3,5    | 45       | 36 | ▲▲▲▲           |                     | 8             | Holzma           | 1        | 58807862     |  |
| 200                  | 4,4-5,2   | 3,5    | 20       | 36 | ▲▲▲▲           |                     | 8             | Schelling        | 1        | 58803073     |  |
| 200                  | 4,4-5,2   | 3,5    | 45       | 36 | ▲▲▲▲           |                     | 8             | Homag            | 1        | 58803074     |  |
| 200                  | 4,85-5,65 | 3,5    | 45       | 36 | ▲▲▲▲           |                     | 8             | Homag            | 1        | 58806134     |  |
| 200                  | 4,45-5,25 | 3,2    | 65       | 36 | ▲▲▲▲           | 2/9/100<br>+2/9/110 | 8             | Selco            | 1        | 58806130     |  |

\* Snijkwaliteit ▲ Zeer grove snede, ▲▲ Grove snede, ▲▲▲ Fijne snede, ▲▲▲▲ Zeer fijne snede

\*\* Extra gaten: Combi1 komt overeen met 2/10/60 + 2/7/42 Combi2 komt overeen met 2/7/42 + 2/9/46 en 2/10/60 Combi3 = 2/10/60 + 2/9/46 + 2/9,5/46,5 + 2/7/42 Combi5 = 2/7/110 + 2/9/110 + 2/8,4/130 + 2/14/110 + 4/9/100 + 4/19/120 Combi7 = 2/9/110 + 2/10/80 + 2/11/85 + 2/11/115 + 2/11/148 + 2/14/100 + 2/14/125 + 2/19/120

Geschikte reduceerringen vindt u aan het einde van dit hoofdstuk



DP

RSK

Voorrits cirkelzaagbladen DP - conische-vlaktand KO-F

Product



Tekening

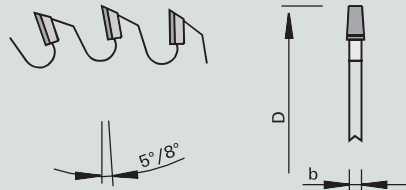

Machine



Toepassing



Uitvoering



4,5 mm

3-0-1

KO-F

Machine / gebruiksaanwijzing

- Platenopdeelzagen met voorritsaggregaat
- Voor het voorritsen van beplakte plaatmaterialen

Uitvoering

- Diamantsnijanten in gepolijste uitvoering
- Tandvorm: conische-vlaktand 'KO-F'
- Snijmateriaal: DP
- Naslijpzone 4,5 mm
- Stamblad gecoat

Voordelen

- Korte levertijden

Informatie - Tip

- Inzetten in meeloop

Producteigenschappen

Bestelinformatie

| Ø D [mm] | B [mm]  | b [mm] | Ø d [mm] | Z  | Snijkwaliteit* | NL**      | Spaanhoek [°] |           |   | VE [St.] | V | Bestelnummer |
|----------|---------|--------|----------|----|----------------|-----------|---------------|-----------|---|----------|---|--------------|
| 160      | 4,4-5,2 | 3,2    | 45       | 30 | ▲▲▲▲           | 3/11/70   | 5             | Giben     | ● | 1        | o | 50750121     |
| 180      | 4,4-5,2 | 3,2    | 30       | 30 | ▲▲▲▲           | 2/10/60   | 5             | Panhans   | ● | 1        | o | 50750122     |
| 180      | 4,4-5,2 | 3,2    | 45       | 30 | ▲▲▲▲           |           | 5             | Holzma    | ● | 1        | o | 50750123     |
| 180      | 4,8-5,6 | 3,5    | 45       | 30 | ▲▲▲▲           |           | 5             | Holzma    | ● | 1        | o | 50750124     |
| 200      | 4,4-5,2 | 3,2    | 20       | 30 | ▲▲▲▲           |           | 5             | Schelling | ● | 1        | o | 50750125     |
| 200      | 4,4-5,2 | 3,2    | 20       | 36 | ▲▲▲▲           |           | 8             | Schelling | ● | 1        | o | 50750147     |
| 200      | 4,8-5,6 | 3,5    | 65       | 30 | ▲▲▲▲           | 2/8,4/110 | 5             | Selco     | ● | 1        | o | 50750126     |
| 200      | 4,8-5,6 | 3,5    | 45       | 30 | ▲▲▲▲           |           | 5             | Holzma    | ● | 1        | o | 50750127     |

\* Snijkwaliteit ▲ Zeer grove snede, ▲▲ Grove snede, ▲▲▲ Fijne snede, ▲▲▲▲ Zeer fijne snede



\*\* Extra gaten: Combi1 komt overeen met 2/10/60 + 2/7/42 Combi2 komt overeen met 2/7/42 + 2/9/46 en 2/10/60 Combi3 = 2/10/60 + 2/9/46 + 2/9.5/46.5 + 2/7/42 Combi5 = 2/7/110 + 2/9/110 + 2/8.4/130 + 2/14/110 + 4/9/100 + 4/19/120 Combi7 = 2/9/110 + 2/10/80 + 2/11/85 + 2/11/115 + 2/11/148 + 2/14/100 + 2/14/125 + 2/19/120

Geschikte reduceerringen vindt u aan het einde van dit hoofdstuk

HW

RSK-WS

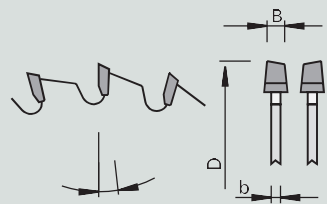
Voorrits cirkelzaagblad HW - conische-wisseltand

|  |   |  |   |  |
|--|---|--|---|--|
| <p>Product</p>  | <p>Tekening</p>  | <p>Machine</p>  | <p>Toepassing</p>  | <p>Uitvoering</p> <p>3-0-1</p> <p>HW<br/>TC04<br/>plus</p> |
|--|---|--|---|--|

|  |   |  |   |
|--|---|--|---|
| <p>Machine / gebruiksaanwijzing</p> <ul style="list-style-type: none"> <li>• Platenopdeelzagen met voorrits-aggregaat</li> <li>• Voor het voorritsen van met kunststof beplakte plaatmaterialen</li> </ul> | <p>Uitvoering</p> <ul style="list-style-type: none"> <li>• Tandvorm: conische-wisseltand 'KO-WS'</li> <li>• Snijmateriaal HW TC04 plus</li> </ul> | <p>Voordelen</p> <ul style="list-style-type: none"> <li>• Kleinere motorbelasting door 'KO-WS'-tandvorm</li> <li>• Voor een langere standtijd in vergelijking met de TC03 plus</li> <li>• Beste snijkwaliteit door verbeterde loopnauwkeurigheid volgens schema</li> <li>• Vermindering van de ritsdiepte</li> </ul> | <p>Informatie - Tip</p> <ul style="list-style-type: none"> <li>• Door hoogterstelling van de as op snijbreedte van de hoofdzaag in te stellen</li> <li>• Optimale voorrits-diepte 1,0 - 2,0 mm</li> </ul> |
|--|---|--|---|





| Producteigenschappen |           |        |          |    |                |               | Bestelinformatie |   |   |  |
|----------------------|-----------|--------|----------|----|----------------|---------------|------------------|---|---|--|
| Ø D [mm]             | B [mm]    | b [mm] | Ø d [mm] | Z  | Snijkwaliteit* | Spaanhoek [°] | VE [St.]         | V | Bestelnummer  |  |
| 180                  | 4,45-5,25 | 3,2    | 30       | 30 | ▲▲▲            | 8             | 1                |   | 58807970 <span style="background-color: #e67e22; color: white; padding: 2px;">NEUW</span> |  |

\* Snijkwaliteit ▲ Zeer grove snede, ▲▲ Grove snede, ▲▲▲ Fijne snede, ▲▲▲▲ Zeer fijne snede

\*\* Extra gaten: Combi1 komt overeen met 2/10/60 + 2/7/42 Combi2 komt overeen met 2/7/42 + 2/9/46 en 2/10/60 Combi3 = 2/10/60 + 2/9/46 + 2/9,5/46,5 + 2/7/42 Combi5 = 2/7/110 + 2/9/110 + 2/8,4/130 + 2/14/110 + 4/9/100 + 4/19/120 Combi7 = 2/9/110 + 2/10/80 + 2/11/85 + 2/11/115 + 2/11/148 + 2/14/100 + 2/14/125 + 2/19/120

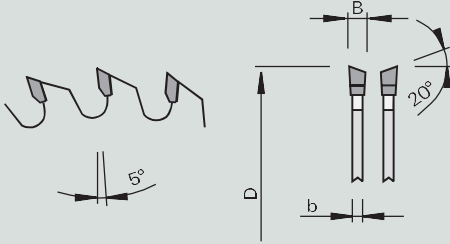
Geschikte reduceerringen vindt u aan het einde van dit hoofdstuk



## HW OKW Optimalisatie-afkortsirkelzaagbladen HW - wisseltand

|   |  |   |   |  |
|---|--|---|---|--|
| Product   | Tekening   | Machine   | Toepassing  | Uitvoering   |
|  |  |  |  | 3-0-1<br><br>HW TCw15<br>WS |

|  |  |           |  |
|--|--|-----------|--|
| Machine / gebruiksaanwijzing   | Uitvoering   | Voordelen | Informatie - Tip   |
| <ul style="list-style-type: none"> <li>• Optimalisatie-afkortsaaagmachine</li> <li>• Voor dwarssnedes in massief hout</li> </ul> | <ul style="list-style-type: none"> <li>• Spaanhoek positief</li> <li>• Tandvorm: wisseltand "WS"</li> <li>• Tandbezetting: HW TCw15</li> </ul> |           | <ul style="list-style-type: none"> <li>• Andere maten op aanvraag</li> </ul> |

| Producteigenschappen |        |        |          |     |                | Bestelinformatie  |               |   |   |              |
|----------------------|--------|--------|----------|-----|----------------|-------------------|---------------|---|---|--------------|
| Ø D [mm]             | B [mm] | b [mm] | Ø d [mm] | Z   | Snijkwaliteit* | NL**              | Spaanhoek [°] | VE [St.]  | V | Bestelnummer |
| 500                  | 4,6    | 3,5    | 30       | 144 | ▲▲▲            | 2/15/63 + 2/10/60 | 5             |  1 |   | 50807842     |

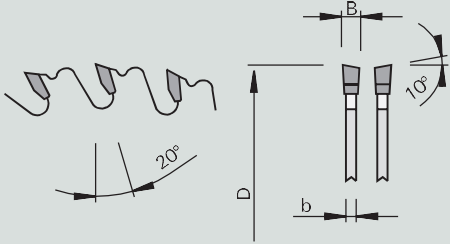
## HW Planet HW Meerblad-cirkelzaagblad met inwendige HW ruimers - wisseltand

|   |  |   |   |                        |
|---|--|---|---|------------------------|
| Product   | Tekening   | Machine   | Toepassing  | Uitvoering             |
|  |  |  |  | 3-0-1<br>HW TC20<br>WS |

|  |  |   |  |
|--|--|---|--|
| Machine / gebruiksaanwijzing   | Uitvoering   | Voordelen   | Informatie - Tip   |
| <ul style="list-style-type: none"> <li>• Tafelcirkelzagen</li> <li>• Langs- en dwarssnedes in nat en droog massief hout</li> </ul> | <ul style="list-style-type: none"> <li>• Tandvorm: wisseltand 'WS'</li> <li>• Snijmateriaal HW TC20</li> <li>• 4 inwendige HW wissers/ruimers</li> </ul> | <ul style="list-style-type: none"> <li>• Geen zijdelings aanlopen van het zaagblad in het hout dmv. HW ruimers/wissers</li> <li>• Uitvoering (spaanbegrensd) zorgt voor een universele inzet</li> </ul> | <ul style="list-style-type: none"> <li>• Geschikt voor manuele aanvoer</li> <li>• Nu met dikker stamblad en grotere zaagbreedte</li> </ul> |

| Producteigenschappen |        |        |          |    |                | Bestelinformatie |                      |   |   |              |
|----------------------|--------|--------|----------|----|----------------|------------------|----------------------|---|---|--------------|
| Ø D [mm]             | B [mm] | b [mm] | Ø d [mm] | Z  | Snijkwaliteit* | NL**             | Santal wissers [St.] | VE [St.]  | V | Bestelnummer |
| 350                  | 3,8    | 2,5    | 30       | 24 | ▲              | Combi2           | 2+2                  |  1 |   | 50804422     |
| 400                  | 4,2    | 3,0    | 30       | 28 | ▲              | Combi2           | 2+2                  |  1 |   | 50804423     |
| 450                  | 4,2    | 3,0    | 30       | 36 | ▲              | Combi2           | 2+2                  |  1 |   | 50804425     |

\* Snijkwaliteit ▲ Zeer grove snede, ▲▲ Grove snede, ▲▲▲ Fijne snede, ▲▲▲▲ Zeer fijne snede



\*\* Extra gaten: Combi1 komt overeen met 2/10/60 + 2/7/42 Combi2 komt overeen met 2/7/42 + 2/9/46 en 2/10/60 Combi3 = 2/10/60 + 2/9/46 + 2/9.5/46.5 + 2/7/42 Combi5 = 2/7/110 + 2/9/110 + 2/8.4/130 + 2/14/110 + 4/9/100 + 4/19/120 Combi7 = 2/9/110 + 2/10/80 + 2/11/85 + 2/11/115 + 2/11/148 + 2/14/100 + 2/14/125 + 2/19/120

Geschikte reduceerringen vindt u aan het einde van dit hoofdstuk

HW

LWR

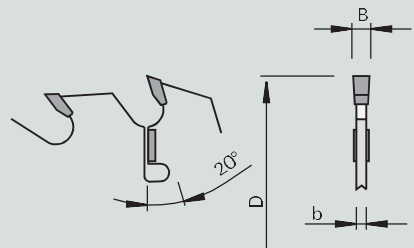
HW Meerblad-cirkelzaagblad met HW ruimers - vlakland

|  |  |  |   |  |
|--|--|--|---|--|
| <p>Product</p>  | <p>Tekening</p>  | <p>Machine</p>  | <p>Toepassing</p>  | <p>Uitvoering</p> <p>3-0-1</p> <p>HW<br/>TC25</p> <p>F</p> |
|--|--|--|---|--|

|   |  |  |  |
|---|--|--|--|
| <p>Machine / gebruiksaanwijzing</p> <ul style="list-style-type: none"> <li>• Enkel- en dubbel-assige meerblad zaagmachines</li> <li>• Voor schulpen in natte en droge zachte houtsoorten</li> </ul> | <p>Uitvoering</p> <ul style="list-style-type: none"> <li>• Tandvorm: vlakland "F"</li> <li>• Tandbezetting: HW TC25</li> </ul> | <p>Voordelen</p> <ul style="list-style-type: none"> <li>• Geen zijdelings aanlopen van het zaagblad in het hout dmv. HW ruimers/wissers</li> </ul> | <p>Informatie - Tip</p> <ul style="list-style-type: none"> <li>• Voor snijhoogten vanaf 50 mm</li> </ul> |
|---|--|--|--|

| Producteigenschappen |        |        |          |    | Bestelinformatie |          |                      |          |                |
|----------------------|--------|--------|----------|----|------------------|----------|----------------------|----------|----------------|
| Ø D [mm]             | B [mm] | b [mm] | Ø d [mm] | Z  | Snijkwaliteit*   | DKN [mm] | Santal wissers [St.] | VE [St.] | V Bestelnummer |
| 250                  | 3,2    | 2.2    | 70       | 20 | ▲                | 2 x 20x5 | 2+2                  | 1        | 50457841       |
| 300                  | 3,4    | 2.2    | 70       | 22 | ▲▲               | 2 x 20x5 | 2+2                  | 1        | 50100525       |
| 350                  | 3,6    | 2.5    | 70       | 20 | ▲▲▲              | 2 x 20x5 | 2+2                  | 1        | 50100528       |
| 350                  | 3,6    | 2.4    | 70       | 28 | ▲▲▲▲             | 2 x 20x5 | 2+2                  | 1        | 50457843       |

\* Snijkwaliteit ▲ Zeer grove snede, ▲▲ Grove snede, ▲▲▲ Fijne snede, ▲▲▲▲ Zeer fijne snede

\*\* Extra gaten: Combi1 komt overeen met 2/10/60 + 2/7/42 Combi2 komt overeen met 2/7/42 + 2/9/46 en 2/10/60 Combi3 = 2/10/60 + 2/9/46 + 2/9.5/46.5 + 2/7/42 Combi5 = 2/7/110 + 2/9/110 + 2/8.4/130 + 2/14/110 + 4/9/100 + 4/19/120 Combi7 = 2/9/110 + 2/10/80 + 2/11/85 + 2/11/115 + 2/11/148 + 2/14/100 + 2/14/125 + 2/19/120

Geschikte reduceerringen vindt u aan het einde van dit hoofdstuk

**HW**

**NE-positief**

NE-Kapcirkelzaagblad HW - positieve spaanhoek trapezium-vlaktand

Product



Tekening

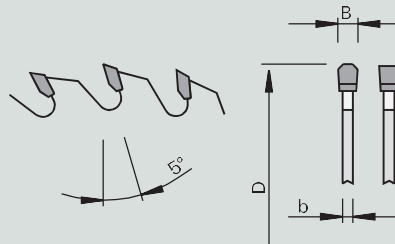

Machine



Toepassing



Uitvoering

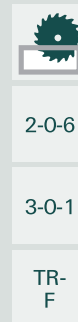

Machine / gebruiksaanwijzing

- Tafelcirkelzagen
- Kap- en radiaalcirkelzagen
- Voor formatteer- en versteeksnedes in aluminium, kunststofprofielen, aluminiumplaten bij machines met werkstuk opspanning en voor plaatmateriaal op basis van hout (Corian®, Noblan, Varicor® en HPL)

Uitvoering

- Spaanhoek positief
- tandvorm: trapezium-vlaktand 'TR-F'
- Kwaliteit 3-0-1 vanaf Ø 301
- Snijmateriaal: HW TC10 vanaf Ø 301 TC06

Voordelen

- Geluidsreductie door laserornamenten

Informatie - Tip

- Goede opspanning van het werkstuk vereist

Producteigenschappen

Bestelinformatie

| Ø D [mm] | B [mm] | b [mm] | Ø d [mm] | Z   | Snijkwaliteit* | NL**              | Spaanhoek [°] | Snijmateriaal | VE [St.] | V | Bestelnummer |
|----------|--------|--------|----------|-----|----------------|-------------------|---------------|---------------|----------|---|--------------|
| 250      | 3,2    | 2,5    | 30       | 80  | ▲▲             | Combi3            | 5             | TC10          | 1        |   | 58808102     |
| 300      | 3,2    | 2,5    | 30       | 72  | ▲▲             | Combi3            | 5             | TC10          | 1        |   | 58808104     |
| 300      | 3,2    | 2,5    | 30       | 96  | ▲▲▲            | Combi3            | 5             | TC10          | 1        |   | 58808107     |
| 300      | 3,2    | 2,5    | 32       | 96  | ▲▲▲            | 4/12/64 + Combi3  | 5             | TC10          | 1        | o | 58808125     |
| 350      | 3,2    | 2,5    | 30       | 108 | ▲▲▲            | Combi3            | 5             | TC06          | 1        |   | 58808111     |
| 400      | 3,8    | 3,2    | 30       | 96  | ▲▲             | Combi3            | 5             | TC06          | 1        |   | 58808113     |
| 420      | 3,8    | 3,2    | 30       | 96  | ▲▲             | Combi3            | 5             | TC06          | 1        |   | 58808115     |
| 450      | 3,8    | 3,2    | 40       | 108 | ▲▲▲            | 4/12/64 + 2/10/60 | 5             | TC06          | 1        |   | 58808117     |
| 500      | 4,0    | 3,4    | 30       | 120 | ▲▲▲            | 4/12/64 + 2/10/60 | 5             | TC06          | 1        |   | 58808118     |

\* Snijkwaliteit ▲ Zeer grove snede, ▲▲ Grove snede, ▲▲▲ Fijne snede, ▲▲▲▲ Zeer fijne snede

\*\* Extra gaten: Combi1 komt overeen met 2/10/60 + 2/7/42 Combi2 komt overeen met 2/7/42 + 2/9/46 en 2/10/60 Combi3 = 2/10/60 + 2/9/46 + 2/9.5/46.5 + 2/7/42 Combi5 = 2/7/110 + 2/9/110 + 2/8.4/130 + 2/14/110 + 4/9/100 + 4/19/120 Combi7 = 2/9/110 + 2/10/80 + 2/11/85 + 2/11/115 + 2/11/148 + 2/14/100 + 2/14/125 + 2/19/120

Geschikte reduceerringen vindt u aan het einde van dit hoofdstuk

HW

NE-negatief

NE-Kapcirkelzaagblad HW - negatieve spaanhoek trapezium-vlaktand

|         |          |         |            |                        |
|---------|----------|---------|------------|------------------------|
| Product | Tekening | Machine | Toepassing | Uitvoering             |
|         |          |         |            | 2-0-6<br>3-0-1<br>TR-F |

|  |   |  |                  |
|--|---|--|------------------|
| Machine / gebruiksaanwijzing   | Uitvoering  | Voordelen  | Informatie - Tip |
| <ul style="list-style-type: none"> <li>• Kap- en radiaal cirkelzagen</li> <li>• Voor het afkorten en verstekzagen van aluminium- en kunststof profielen</li> </ul> | <ul style="list-style-type: none"> <li>• Spaanhoek negatief</li> <li>• tandvorm: trapezium-vlaktand 'TR-F'</li> <li>• Kwaliteit 3-0-1 vanaf Ø 301</li> <li>• Snijmateriaal: HW TC10 vanaf Ø 301 TC06</li> </ul> | <ul style="list-style-type: none"> <li>• Geluidsreductie door laserornamenten</li> </ul> |                  |

| Producteigenschappen |        |        |          |     |                |                            |               | Bestelinformatie |          |   |              |
|----------------------|--------|--------|----------|-----|----------------|----------------------------|---------------|------------------|----------|---|--------------|
| Ø D [mm]             | B [mm] | b [mm] | Ø d [mm] | Z   | Snijkwaliteit* | NL**                       | Spaanhoek [°] |                  | VE [St.] | V | Bestelnummer |
| 235                  | 2,8    | 2,2    | 30       | 64  | ▲▲             | 2/7/42                     | -6            |                  | 1        |   | 58115018     |
| 250                  | 3,2    | 2,5    | 30       | 60  | ▲▲             | Combi3                     | -6            |                  | 1        |   | 58808201     |
| 250                  | 2,8    | 2,2    | 30       | 80  | ▲▲▲            | Combi3                     | -6            |                  | 1        |   | 58808200     |
| 250                  | 3,2    | 2,5    | 30       | 80  | ▲▲▲            | Combi3                     | -6            |                  | 1        |   | 58808203     |
| 250                  | 3,2    | 2,5    | 32       | 60  | ▲▲             | Combi3                     | -6            |                  | 1        | o | 58808202     |
| 250                  | 3,2    | 2,5    | 32       | 80  | ▲▲▲            | Combi3                     | -6            |                  | 1        | o | 58808204     |
| 250                  | 3,2    | 2,5    | 40       | 80  | ▲▲▲            | 4/12/64 + 2/9/55 + Combi3  | -6            |                  | 1        | o | 58808205     |
| 254                  | 3,2    | 2,5    | 30       | 80  | ▲▲▲            | Combi3                     | -6            |                  | 1        | o | 58808246     |
| 260                  | 3,2    | 2,5    | 30       | 72  | ▲▲             | Combi3                     | -6            |                  | 1        |   | 58808206     |
| 300                  | 3,2    | 2,5    | 30       | 72  | ▲▲             | Combi3                     | -6            |                  | 1        |   | 58808209     |
| 300                  | 3,2    | 2,5    | 30       | 84  | ▲▲▲            | Combi3                     | -6            |                  | 1        | o | 58808244     |
| 300                  | 2,8    | 2,2    | 30       | 96  | ▲▲▲            | Combi3                     | -6            |                  | 1        |   | 58808213     |
| 300                  | 3,2    | 2,5    | 30       | 96  | ▲▲▲            | Combi3                     | -6            |                  | 1        |   | 58808214     |
| 300                  | 3,2    | 2,5    | 32       | 96  | ▲▲▲            | 4/12/64                    | -6            |                  | 1        |   | 58808215     |
| 300                  | 3,3    | 2,5    | 40       | 96  | ▲▲▲            | 4/12/64 + 2/9/55           | -6            |                  | 1        |   | 58808216     |
| 305                  | 3,2    | 2,5    | 30       | 96  | ▲▲▲            | Combi3                     | -6            |                  | 1        |   | 58808245     |
| 305                  | 3,2    | 2,5    | 30       | 60  | ▲▲             | Combi3                     | -6            |                  | 1        |   | 58808241     |
| 330                  | 3,2    | 2,5    | 30       | 96  | ▲▲▲            | Combi3                     | -6            |                  | 1        |   | 58808217     |
| 330                  | 3,2    | 2,5    | 32       | 96  | ▲▲▲            | Combi3                     | -6            |                  | 1        | o | 58808218     |
| 350                  | 3,2    | 2,5    | 30       | 90  | ▲▲             | Combi3                     | -6            |                  | 1        |   | 58808222     |
| 350                  | 3,2    | 2,5    | 30       | 108 | ▲▲▲            | Combi3                     | -6            |                  | 1        |   | 58808225     |
| 350                  | 3,2    | 2,5    | 32       | 108 | ▲▲▲            | 4/12/64                    | -6            |                  | 1        |   | 58808226     |
| 350                  | 3,2    | 2,5    | 40       | 108 | ▲▲             | 4/12/64 + 2/9/55           | -6            |                  | 1        | o | 58808227     |
| 380                  | 3,8    | 3,2    | 32       | 110 | ▲▲▲            | 4/12/64                    | -6            |                  | 1        |   | 58808243     |
| 400                  | 3,8    | 3,2    | 30       | 96  | ▲▲             | Combi3                     | -6            |                  | 1        |   | 58808232     |
| 420                  | 4,0    | 3,2    | 30       | 96  | ▲▲             | Combi3                     | -6            |                  | 1        |   | 58808234     |
| 420                  | 3,8    | 3,2    | 40       | 100 | ▲▲▲            | 4/12/64 + 2/9/55           | -6            |                  | 1        |   | 58808236     |
| 450                  | 3,8    | 3,2    | 30       | 96  | ▲▲             | 4/12/64 + 2/12/80 + Combi3 | -6            |                  | 1        |   | 58808235     |
| 500                  | 4,0    | 3,4    | 30       | 120 | ▲▲▲            | 4/12/64 + 2/10/60          | -6            |                  | 1        |   | 58808239     |

\* Snijkwaliteit ▲ Zeer grove snede, ▲▲ Grove snede, ▲▲▲ Fijne snede, ▲▲▲▲ Zeer fijne snede

\*\* Extra gaten: Combi1 komt overeen met 2/10/60 + 2/7/42 Combi2 komt overeen met 2/7/42 + 2/9/46 en 2/10/60 Combi3 = 2/10/60 + 2/9/46 + 2/9,5/46,5 + 2/7/42 Combi5 = 2/7/110 + 2/9/110 + 2/8,4/130 + 2/14/110 + 4/9/100 + 4/19/120 Combi7 = 2/9/110 + 2/10/80 + 2/11/85 + 2/11/115 + 2/11/148 + 2/14/100 + 2/14/125 + 2/19/120

Geschikte reduceerringen vindt u aan het einde van dit hoofdstuk

**HW NE - Positief - Profiel 'G7'**  
NE-Kapcirkelzaagblad HW - positieve spaanhoek - profiel 'G7'

Product

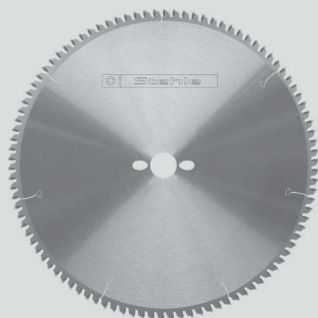

Tekening

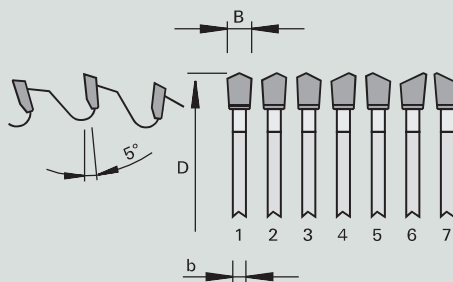

Machine



Toepassing



Uitvoering



3-0-1

HW  
TC06

G7

Machine / gebruiksaanwijzing

- Tafelcirkelzagen
- Voor braamvrije en gladde snedes in dunwandige aluminium kozijnen en gevelprofielen alsook PVC-profielen

Uitvoering

- Spaanhoek positief
- Tandvorm: 'G7'
- Snijmateriaal HW TC06

Voordelen

- Verminderen snijdruk door groepstandgeometrie
- Uitstekende snedes met geringe ruwheidsdiepte door speciale tandsplitsing
- Extreem geluidsarm door speciale laserornamenten
- Langere standtijd in vergelijking met cirkelzaagbladen met tandvorm 'TR-F'
- Betere prestaties en rendabiliteit

Informatie - Tip

- Goede werkstukopspanning vereist
- Wanddikte max. 5 mm

Producteigenschappen

Bestelinformatie

| Ø D [mm] | B [mm] | b [mm] | Ø d [mm] | Z   | Snijkwaliteit* | NL  | Spaanhoek [°] | VE [St.] | V | Bestelnummer |
|----------|--------|--------|----------|-----|----------------|---|---------------|----------|---|--------------|
| 300      | 3,2    | 2,5    | 30       | 98  | ▲▲▲▲           | 2/7/42 +<br>2/9/46 +<br>2/10/60 +<br>2/11/70              | 5             | 1        |   | 58192663     |
| 350      | 3,2    | 2,5    | 30       | 98  | ▲▲▲▲           | 2/7/42 +<br>2/9/46 +<br>2/10/60                           | 5             | 1        |   | 58192662     |
| 400      | 3,8    | 3,2    | 30       | 98  | ▲▲▲▲           | 2/7/42 +<br>2/9/46 +<br>2/10/60 +<br>2/15/80 +<br>4/12/64 | 5             | 1        |   | 58192659     |
| 420      | 3,8    | 3,2    | 30       | 98  | ▲▲▲▲           |   | 5             | 1        |   | 58192660     |
| 500      | 4,0    | 3,4    | 30       | 126 | ▲▲▲▲           | 2/7/42 +<br>2/9/46 +<br>2/10/60 +<br>2/10/70 +<br>4/12/64 | 5             | 1        |   | 58192661     |

\* Snijkwaliteit ▲ Zeer grove snede, ▲▲ Grove snede, ▲▲▲ Fijne snede, ▲▲▲▲ Zeer fijne snede

\*\* Extra gaten: Combi1 komt overeen met 2/10/60 + 2/7/42 Combi2 komt overeen met 2/7/42 + 2/9/46 en 2/10/60 Combi3 = 2/10/60 + 2/9/46 + 2/9.5/46.5 + 2/7/42 Combi5 = 2/7/110 + 2/9/110 + 2/8.4/130 + 2/14/110 + 4/9/100 + 4/19/120 Combi7 = 2/9/110 + 2/10/80 + 2/11/85 + 2/11/115 + 2/11/148 + 2/14/100 + 2/14/125 + 2/19/120

Geschikte reduceerringen vindt u aan het einde van dit hoofdstuk

# HW NE - Kap - Negatief - Profiel 'G7'

NE-Kapcirkelzaagblad HW - negatieve spaanhoek - profiel 'G7'

Product

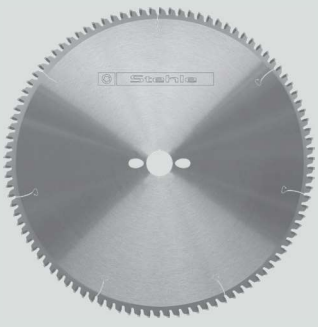

Tekening

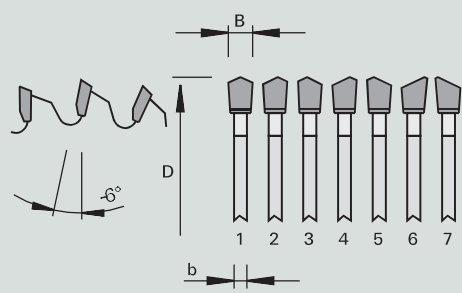

Machine



Toepassing



Uitvoering



3-0-1

HW  
TC06

G7

- |   |   |   |   |
|---|---|---|---|
| <p>Machine / gebruiksaanwijzing</p> <ul style="list-style-type: none"> <li>• Kap- en radiaal cirkelzagen</li> <li>• Voor kap- en versteksnedes in PVC-profielen</li> <li>• Voor braamvrije en gladde snedes in dunwandige aluminium kozijnen en gevelprofielen</li> </ul> | <p>Uitvoering</p> <ul style="list-style-type: none"> <li>• Spaanhoek negatief</li> <li>• Tandvorm: 'G7'</li> <li>• Snijmateriaal HW TC06</li> </ul> | <p>Voordelen</p> <ul style="list-style-type: none"> <li>• Verminderen snijdruk door groepstandgeometrie</li> <li>• Uitstekende snedes met geringe ruwheidsdiepte door speciale tandplitsing</li> <li>• Extreem geluidsarm door speciale laserornamenten</li> <li>• Langere standtijd in vergelijking met kapcirkelzaagbladen met tandvorm 'TR-F'</li> <li>• Betere prestaties en rendabiliteit</li> </ul> | <p>Informatie - Tip</p> <ul style="list-style-type: none"> <li>• Goede werkstukopspanning vereist</li> <li>• Wanddikte max. 5 mm</li> </ul> |
|---|---|---|---|

| Producteigenschappen |        |        |          |     |                |  |               | Bestelinformatie |          |   |              |
|----------------------|--------|--------|----------|-----|----------------|--|---------------|------------------|----------|---|--------------|
| Ø D [mm]             | B [mm] | b [mm] | Ø d [mm] | Z   | Snijkwaliteit* | NL                                     | Spaanhoek [°] |                  | VE [St.] | V   | Bestelnummer |
| 250                  | 3,2    | 2,5    | 30       | 84  | ▲▲▲▲           | 2/7/42 + 2/9/46 + 2/9,5/46,5 + 2/10/60 | -6            |                  | 1        |   | 58192965     |
| 300                  | 3,2    | 2,5    | 30       | 98  | ▲▲▲▲           | 2/11/70                                | -6            |                  | 1        |   | 58192568     |
| 350                  | 3,2    | 2,5    | 30       | 112 | ▲▲▲▲           | 2/7/42 + 2/9/46 + 2/9,5/46,5 + 2/10/60 | -6            |                  | 1        |   | 58192275     |
| 350                  | 3,5    | 2,8    | 30       | 98  | ▲▲▲▲           | 2/7/42 + 2/9/46 + 2/9,5/46,5 + 2/10/60 | -6            |                  | 1        | DeWALT, Haffner, Pfeiffer, Rotox                          | 58192274     |
| 350                  | 3,8    | 3,2    | 40       | 84  | ▲▲▲▲           | 4/12/64 + 2/9/55                       | -6            |                  | 1        | Eisele LSM II, -LSM II-PV, -VA-L, Graule, Ulmia, Weidmann | 58192273     |
| 380                  | 3,8    | 3,2    | 32       | 112 | ▲▲▲▲           |  | -6            |                  | 1        | Elumatec  | 58192567     |
| 400                  | 3,8    | 3,2    | 30       | 98  | ▲▲▲▲           | 2/10/60 + 2/12/64 + 4/15/80            | -6            |                  | 1        | DeWALT, Haffner   | 58192276     |
| 420                  | 4,0    | 3,2    | 30       | 98  | ▲▲▲▲           | 2/10/60 + 2/11/70                      | -6            |                  | 1        | Rapid, ELU  | 58192277     |
| 450                  | 3,8    | 3,2    | 30       | 112 | ▲▲▲▲           | 2/10/60 + 2/12/64 + 4/15/80            | -6            |                  | 1        | DeWALT, Haffner   | 58192278     |
| 500                  | 4,0    | 3,4    | 30       | 126 | ▲▲▲▲           | 2/11/70 + 2/10/60                      | -6            |                  | 1        | Pfeiffer, Rapid   | 58192279     |
| 550                  | 4,0    | 3,4    | 30       | 133 | ▲▲▲▲           | 2/10/60 + 2/12/64 + 4/15/80            | -6            |                  | 1        | Pfeiffer, Rapid   | 58192392     |

\* Snijkwaliteit ▲ Zeer grove snede, ▲▲ Grove snede, ▲▲▲ Fijne snede, ▲▲▲▲ Zeer fijne snede  
 \*\* Extra gaten: Combi1 komt overeen met 2/10/60 + 2/7/42 Combi2 komt overeen met 2/7/42 + 2/9/46 en 2/10/60 Combi3 = 2/10/60 + 2/9/46 + 2/9,5/46,5 + 2/7/42 Combi5 = 2/7/110 + 2/9/110 + 2/8,4/130 + 2/14/110 + 4/9/100 + 4/19/120 Combi7 = 2/9/110 + 2/10/80 + 2/11/85 + 2/11/115 + 2/11/148 + 2/14/100 + 2/14/125 + 2/19/120  
 Geschikte reduceerringen vindt u aan het einde van dit hoofdstuk



**HW**

**Unisteel**

Metaal-afkortcirkelzaagbladen HW - spaanhoek neutraal vlakland met wissel fase

Product



Tekening

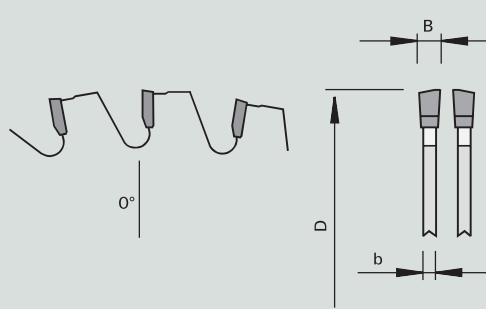

Machine



Toepassing



Uitvoering

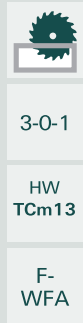

Machine / gebruiksaanwijzing

- Tafelcirkelzagen
- Kap- en radiaalcirkelzagen
- voor zaagsneden in metalen en NE-metalen, (zink), lood, gietijzer, etc.

Uitvoering

- Tandvorm: vlakland met wissel fase 'F-WFA'
- Snijmateriaal: HW TCm 13

Voordelen

- Verbeterde snijkwaliteit door speciale tandgeometrie

Informatie - Tip

- Voor plaatmaterialen en kunststoffen zie ZWS en Parat-negatief (HKS)
- Kleinere standtijd bij edelstalen

Producteigenschappen

Bestelinformatie

| Ø D [mm] | B [mm] | b [mm] | Ø d [mm] | Z  | Snijkwaliteit* | NL**   | Spaanhoek [°] | VE [St.] | V | Bestelnummer |
|----------|--------|--------|----------|----|----------------|--------|---------------|----------|---|--------------|
| 254      | 2,4    | 1,8    | 30       | 48 | ▲              | Combi3 | 0             | 1        |   | 58165001     |
| 260      | 2,5    | 1,8    | 30       | 60 | ▲              | Combi3 | 0             | 1        |   | 58165010     |
| 270      | 2,6    | 2,2    | 30       | 54 | ▲▲             | Combi3 | 0             | 1        |   | 58116517     |
| 305      | 2,6    | 2,2    | 30       | 60 | ▲▲             | Combi3 | 0             | 1        |   | 58165002     |
| 330      | 2,6    | 2,2    | 30       | 54 | ▲              | Combi3 | 0             | 1        |   | 58165005     |
| 355      | 2,6    | 2,2    | 30       | 80 | ▲▲             | Combi3 | 0             | 1        |   | 58165003     |
| 400      | 2,6    | 2,2    | 30       | 84 | ▲▲             | Combi3 | 0             | 1        | o | 58165004     |
| 450      | 2,6    | 2,2    | 30       | 90 | ▲▲             | Combi3 | 0             | 1        |   | 58165006     |

\* Snijkwaliteit ▲ Zeer grove snede, ▲▲ Grove snede, ▲▲▲ Fijne snede, ▲▲▲▲ Zeer fijne snede

\*\* Extra gaten: Combi1 komt overeen met 2/10/60 + 2/7/42 Combi2 komt overeen met 2/7/42 + 2/9/46 en 2/10/60 Combi3 = 2/10/60 + 2/9/46 + 2/9.5/46.5 + 2/7/42 Combi5 = 2/7/110 + 2/9/110 + 2/8.4/130 + 2/14/110 + 4/9/100 + 4/19/120 Combi7 = 2/9/110 + 2/10/80 + 2/11/85 + 2/11/115 + 2/11/148 + 2/14/100 + 2/14/125 + 2/19/120

Geschikte reduceerringen vindt u aan het einde van dit hoofdstuk

HW

Steel

Metaal-afkortcirkelzaagbladen HW - spaanhoek neutraal vlakland met wissel fase

Product

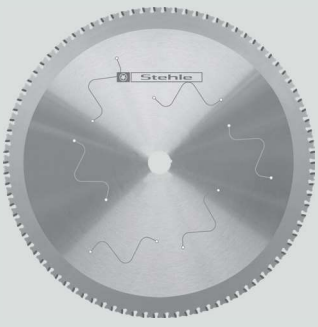

Tekening

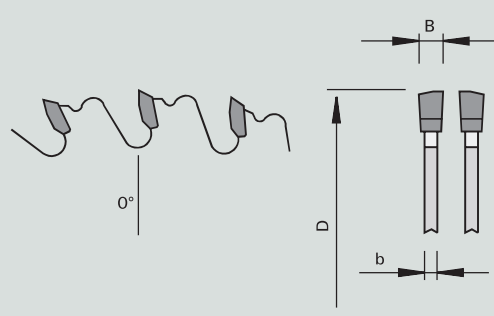

Machine



Toepassing



Uitvoering



3-0-1

HW  
TCm13

F-  
WFA

|  |   |  |  |
|--|---|--|--|
| <p>Machine / gebruiksaanwijzing</p> <ul style="list-style-type: none"> <li>• Dry-cut (Droogzaag) machines</li> <li>• Universeel metaalzaagmachines</li> <li>• Voor zaagsneden in samengestelde materialen, lood, kunststoffen, Ne-materialen, kabelgoten, kabel, profielen, SML-buis etc.</li> </ul> | <p>Uitvoering</p> <ul style="list-style-type: none"> <li>• Tandvorm: vlakland met wissel fase "F-WFA"</li> <li>• Tandbezetting: HW TCm13</li> </ul> | <p>Voordelen</p> <ul style="list-style-type: none"> <li>• Droog zagen</li> <li>• Optimale snijkwaliteit</li> </ul> | <p>Informatie - Tip</p> <ul style="list-style-type: none"> <li>• Aanbevolen omwentelingen per minuut (RPM):</li> <li>• Ø254 = 1750 min-1</li> <li>• Ø305 = 1500 min-1</li> <li>• Ø330 = 1350 min-1</li> <li>• Ø355 = 1250 min-1</li> </ul> |
|--|---|--|--|

| Producteigenschappen |        |        |          |    |                |        | Bestelinformatie |          |   |              |
|----------------------|--------|--------|----------|----|----------------|--------|------------------|----------|---|--------------|
| Ø D [mm]             | B [mm] | b [mm] | Ø d [mm] | Z  | Snijkwaliteit* | NL**   | Spaanhoek [°]    | VE [St.] | V | Bestelnummer |
| 254                  | 2,2    | 1,8    | 30       | 60 | ▲▲             | Combi3 | 0                |          | 1 | 58805861     |
| 305                  | 2,2    | 1,8    | 25,4     | 60 | ▲▲             |        | 0                |          | 1 | 58805862     |
| 305                  | 2,2    | 1,8    | 25,4     | 80 | ▲▲             |        | 0                |          | 1 | 58805863     |
| 305                  | 2,2    | 1,8    | 30       | 80 | ▲▲▲            | Combi3 | 0                |          | 1 | 58805864     |
| 320                  | 2,2    | 1,8    | 25,4     | 84 | ▲▲▲            |        | 0                |          | 1 | 58805859     |
| 330                  | 2,2    | 1,8    | 30       | 90 | ▲▲▲            | Combi3 | 0                |          | 1 | 58805865     |
| 355                  | 2,2    | 1,8    | 25,4     | 80 | ▲▲▲            |        | 0                |          | 1 | 58805866     |
| 355                  | 2,2    | 1,8    | 25,4     | 90 | ▲▲▲            |        | 0                |          | 1 | 58805868     |
| 355                  | 2,2    | 1,8    | 30       | 90 | ▲▲▲            | Combi3 | 0                |          | 1 | 58805867     |

\* Snijkwaliteit ▲ Zeer grove snede, ▲▲ Grove snede, ▲▲▲ Fijne snede, ▲▲▲▲ Zeer fijne snede

\*\* Extra gaten: Combi1 komt overeen met 2/10/60 + 2/7/42 Combi2 komt overeen met 2/7/42 + 2/9/46 en 2/10/60 Combi3 = 2/10/60 + 2/9/46 + 2/9,5/46,5 + 2/7/42 Combi5 = 2/7/110 + 2/9/110 + 2/8,4/130 + 2/14/110 + 4/9/100 + 4/19/120 Combi7 = 2/9/110 + 2/10/80 + 2/11/85 + 2/11/115 + 2/11/148 + 2/14/100 + 2/14/125 + 2/19/120

Geschikte reduceerringen vindt u aan het einde van dit hoofdstuk

# HT Mega-Steel

Metaal-afkortcirkelzaagbladen HT - spaanhoek neutraal

Product

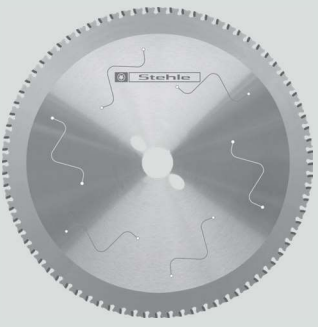

Tekening

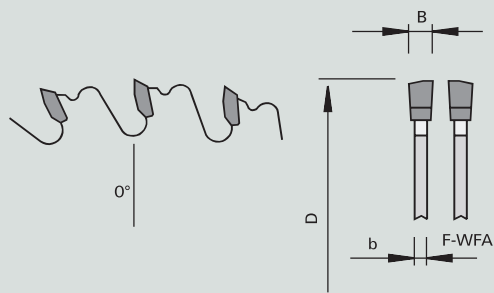

Machine



Toepassing



Uitvoering



3-0-1

HW  
TCx03

F-  
WFA

- |   |   |   |  |
|---|---|---|--|
| <p>Machine / gebruiksaanwijzing</p> <ul style="list-style-type: none"> <li>• Dry-cut (Droogzaag) machines</li> <li>• Universeel metaalzaagmachines</li> <li>• Voor zaagsneden in samengestelde materialen, edelstaal, lood, kunststoffen, Ne-materialen, kabelgoten, kabelprofielen, SML-buis etc.</li> </ul> | <p>Uitvoering</p> <ul style="list-style-type: none"> <li>• Tandvorm: vlakland met wissel fase 'F-WFA'</li> <li>• Snijmateriaal: HT TCx03</li> </ul> | <p>Voordelen</p> <ul style="list-style-type: none"> <li>• Droog zagen</li> <li>• Optimale snijkwaliteit</li> <li>• Extreem lange standtijd</li> </ul> | <p>Informatie - Tip</p> <ul style="list-style-type: none"> <li>• Voor kleinere maten adviseren we onze types Parat - Negativ, HKS Unisteel en HKS Mega-Steel</li> <li>• aanbev. 1/min (RPM):</li> <li>• Ø250 = 1750 min-1</li> <li>• Ø305 = 1500 min-1</li> <li>• Ø355 = 1250 min-1</li> </ul> |
|---|---|---|--|





| Producteigenschappen |        |        |          |    |                |        |               | Bestelinformatie |          |   |              |
|----------------------|--------|--------|----------|----|----------------|--------|---------------|------------------|----------|---|--------------|
| Ø D [mm]             | B [mm] | b [mm] | Ø d [mm] | Z  | Snijkwaliteit* | NL**   | Spaanhoek [°] | Tandvorm         | VE [St.] | V | Bestelnummer |
| 254                  | 2,2    | 1,8    | 25,4     | 72 | ▲▲             |        | 0             | F-WFA            | 1        |   | 58805870     |
| 254                  | 2,2    | 1,8    | 30       | 72 | ▲▲             | Combi3 | 0             | F-WFA            | 1        |   | 58805871     |
| 305                  | 2,2    | 1,8    | 25,4     | 60 | ▲▲             |        | 0             | F-WFA            | 1        |   | 50805872     |
| 305                  | 2,2    | 1,8    | 25,4     | 80 | ▲▲▲            |        | 0             | F-WFA            | 1        |   | 50805873     |
| 330                  | 2,2    | 1,8    | 30       | 90 | ▲▲▲            |        | 0             | F-WFA            | 1        | o | 50805875     |
| 305                  | 2,2    | 1,8    | 30       | 80 | ▲▲▲            | Combi3 | 0             | F-WFA            | 1        |   | 50805874     |
| 355                  | 2,2    | 1,8    | 25,4     | 80 | ▲▲▲            |        | 0             | F-WFA            | 1        |   | 50805876     |
| 355                  | 2,2    | 1,8    | 25,4     | 90 | ▲▲▲            |        | 0             | F-WFA            | 1        |   | 50805878     |
| 355                  | 2,2    | 1,8    | 30       | 90 | ▲▲▲            | Combi3 | 0             | F-WFA            | 1        |   | 50805877     |

\* Snijkwaliteit ▲ Zeer grove snede, ▲▲ Grove snede, ▲▲▲ Fijne snede, ▲▲▲▲ Zeer fijne snede  
 \*\* Extra gaten: Combi1 komt overeen met 2/10/60 + 2/7/42 Combi2 komt overeen met 2/7/42 + 2/9/46 en 2/10/60 Combi3 = 2/10/60 + 2/9/46 + 2/9.5/46.5 + 2/7/42 Combi5 = 2/7/110 + 2/9/110 + 2/8.4/130 + 2/14/110 + 4/9/100 + 4/19/120 Combi7 = 2/9/110 + 2/10/80 + 2/11/85 + 2/11/115 + 2/11/148 + 2/14/100 + 2/14/125 + 2/19/120  
 Geschikte reduceerringen vindt u aan het einde van dit hoofdstuk

HW

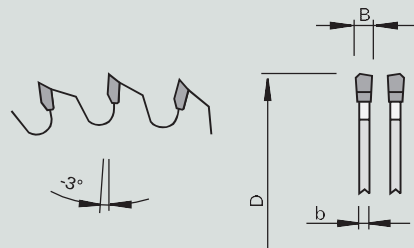
KKS - Plastic

Afkort-cirkelzaagbladen HW voor kunststofprofielen - wisseltand-fase

|  |  |  |   |   |
|--|--|--|---|---|
| <p>Product</p>  | <p>Tekening</p>  | <p>Machine</p>  | <p>Toepassing</p>  | <p>Uitvoering</p>   <p>2-0-6</p> <p>WS-FA</p> |
|--|--|--|---|---|

|   |  |  |                         |
|---|--|--|-------------------------|
| <p>Machine / gebruiksaanwijzing</p> <ul style="list-style-type: none"> <li>• Kap- en radiaal-cirkelzagen</li> <li>• Tafelcirkelzagen</li> <li>• Voor zaagsneden in Kunststof profielen van bijv. PVC, acryl, plexiglas, duroplast materialen, PE, PA, PU, etc.</li> </ul> | <p>Uitvoering</p> <ul style="list-style-type: none"> <li>• Tandvorm: wisseltand-fase "WS-FA"</li> <li>• Tandbezetting: HW TC10 vanaf Ø 250 TC06</li> </ul> | <p>Voordelen</p> <ul style="list-style-type: none"> <li>• Geluidsreductie door laser-ornamenten</li> </ul> | <p>Informatie - Tip</p> |
|---|--|--|-------------------------|

| Producteigenschappen |        |        |          |     |                |        |               |               |          | Bestelinformatie |              |
|----------------------|--------|--------|----------|-----|----------------|--------|---------------|---------------|----------|------------------|--------------|
| Ø D [mm]             | B [mm] | b [mm] | Ø d [mm] | Z   | Snijkwaliteit* | NL**   | Spaanhoek [°] | Snijmateriaal | VE [St.] | V                | Bestelnummer |
| 160                  | 2,2    | 1,6    | 20       | 48  | ▲▲             |        | -3            | TC10          | 1        |                  | 58116000     |
| 190                  | 2,2    | 1,6    | 30       | 54  | ▲▲             |        | -3            | TC10          | 1        |                  | 58116001     |
| 216                  | 2,8    | 2,2    | 30       | 60  | ▲▲             |        | -3            | TC10          | 1        |                  | 58116002     |
| 232                  | 2,8    | 2,2    | 30       | 72  | ▲▲             |        | -3            | TC10          | 1        |                  | 58116003     |
| 250                  | 2,8    | 2,2    | 30       | 80  | ▲▲▲            | Combi3 | -3            | TC06          | 1        |                  | 50808500     |
| 300                  | 2,8    | 2,2    | 30       | 96  | ▲▲▲            | Combi3 | -3            | TC06          | 1        |                  | 50808501     |
| 350                  | 2,8    | 2,2    | 30       | 100 | ▲▲▲            | Combi3 | -3            | TC06          | 1        |                  | 50808502     |

\* Snijkwaliteit ▲ Zeer grove snede, ▲▲ Grove snede, ▲▲▲ Fijne snede, ▲▲▲▲ Zeer fijne snede

\*\* Extra gaten: Combi1 komt overeen met 2/10/60 + 2/7/42 Combi2 komt overeen met 2/7/42 + 2/9/46 en 2/10/60 Combi3 = 2/10/60 + 2/9/46 + 2/9.5/46.5 + 2/7/42 Combi5 = 2/7/110 + 2/9/110 + 2/8.4/130 + 2/14/110 + 4/9/100 + 4/19/120 Combi7 = 2/9/110 + 2/10/80 + 2/11/85 + 2/11/115 + 2/11/148 + 2/14/100 + 2/14/125 + 2/19/120

Geschikte reduceerringen vindt u aan het einde van dit hoofdstuk

HW

## KKS - Hard plastic positief

Afkort-cirkelzaagbladen HW voor zeer harde kunststofprofielen - trapezium-vlaktand

Product



Tekening

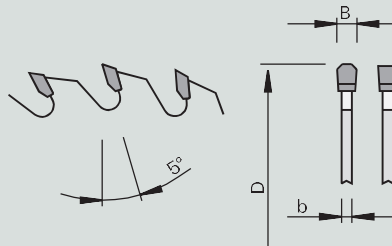

Machine



Toepassing



Uitvoering



Machine / gebruiksaanwijzing

- Tafelcirkelzagen
- voor zaagsneden in kunststof profielen van bijv. Corian®, Varicor®, Trespa®, laminaat, etc.

Uitvoering

- Spaanhoek positief
- tandvorm: trapezium-vlaktand 'TR-F'
- Snijmateriaal HW TC06

Voordelen

- Geluidsreductie door laser-ornamenten

Informatie - Tip

Producteigenschappen

Bestelinformatie

| Ø D [mm] | B [mm] | b [mm] | Ø d [mm] | Z   | Snijkwaliteit* | NL**   | Spaanhoek [°] |  | VE [St.] | V | Bestelnummer         |
|----------|--------|--------|----------|-----|----------------|--------|---------------|--|----------|---|----------------------|
| 250      | 2,8    | 1,8    | 30       | 80  | ▲▲▲            | Combi3 | 5             |  | 1        |   | 58808620 <b>NEUW</b> |
| 300      | 3,2    | 2,5    | 30       | 96  | ▲▲▲            | Combi3 | 5             |  | 1        |   | 58808621 <b>NEUW</b> |
| 350      | 3,5    | 2,8    | 30       | 108 | ▲▲▲            | Combi3 | 5             |  | 1        |   | 58808622 <b>NEUW</b> |
| 400      | 3,5    | 2,8    | 30       | 108 | ▲▲▲            | Combi3 | 5             |  | 1        |   | 58808623 <b>NEUW</b> |

\* Snijkwaliteit ▲ Zeer grove snede, ▲▲ Grove snede, ▲▲▲ Fijne snede, ▲▲▲▲ Zeer fijne snede





\*\* Extra gaten: Combi1 komt overeen met 2/10/60 + 2/7/42 Combi2 komt overeen met 2/7/42 + 2/9/46 en 2/10/60 Combi3 = 2/10/60 + 2/9/46 + 2/9.5/46.5 + 2/7/42 Combi5 = 2/7/110 + 2/9/110 + 2/8.4/130 + 2/14/110 + 4/9/100 + 4/19/120 Combi7 = 2/9/110 + 2/10/80 + 2/11/85 + 2/11/115 + 2/11/148 + 2/14/100 + 2/14/125 + 2/19/120

Geschikte reduceerringen vindt u aan het einde van dit hoofdstuk

**HW**

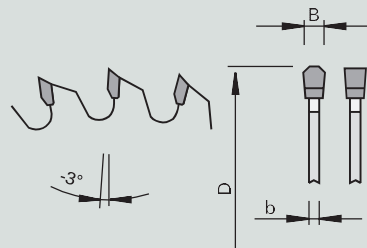
**KKS - Hard plastic negatief**

Afkort-cirkelzaagbladen HW voor zeer harde kunststofprofielen - trapezium-vlaktand

|  |   |  |
|--|---|--|
| <p>Product</p>  | <p>Tekening</p>  | <p>Machine</p>  <p>Toepassing</p>  <p>Uitvoering</p>  <p>3-0-1</p> <p>HW<br/>TC06</p> <p>TR-<br/>F-FA</p> |
|--|---|--|

|  |   |  |                         |
|--|---|--|-------------------------|
| <p>Machine / gebruiksaanwijzing</p> <ul style="list-style-type: none"> <li>• Kap- en radiaal-cirkelzagen</li> <li>• voor zaagsneden in kunststof profielen van bijv. Corian®, Varicor®, Trespa®, laminaat, etc.</li> </ul> | <p>Uitvoering</p> <ul style="list-style-type: none"> <li>• Spaanhoek negatief</li> <li>• Tandvorm: trapezium-vlaktand met tweezijdige fase 'TR-F-FA'</li> <li>• Snijmateriaal HW TC06</li> <li>• Ident. 50808601/ 50808600: Spaanhoek neutraal</li> </ul> | <p>Voordelen</p> <ul style="list-style-type: none"> <li>• Geluidsreductie door laser-ornamenten</li> </ul> | <p>Informatie - Tip</p> |
|--|---|--|-------------------------|

| Producteigenschappen |        |        |          |    |                |        |               | Bestelinformatie |   |                      |
|----------------------|--------|--------|----------|----|----------------|--------|---------------|------------------|---|----------------------|
| Ø D [mm]             | B [mm] | b [mm] | Ø d [mm] | Z  | Snijkwaliteit* | NL**   | Spaanhoek [°] | VE [St.]         | V | Bestelnummer         |
| 210                  | 2,8    | 1,8    | 30       | 54 | ▲▲▲            | 2/7/42 | 0             | 1                | # | 50808601             |
| 210                  | 2,8    | 1,8    | 30       | 54 | ▲▲▲            | 2/7/42 | -3            | 1                |   | 58808610 <b>NEUW</b> |
| 216                  | 2,8    | 1,8    | 30       | 60 | ▲▲▲            | 2/7/42 | -3            | 1                |   | 58808611 <b>NEUW</b> |
| 250                  | 3,2    | 2,5    | 30       | 72 | ▲▲▲            | Combi3 | 0             | 1                | # | 50808600             |
| 254                  | 2,8    | 1,8    | 30       | 80 | ▲▲▲            | Combi3 | -3            | 1                |   | 58808612 <b>NEUW</b> |
| 260                  | 2,5    | 1,8    | 30       | 80 | ▲▲▲            | Combi3 | -3            | 1                |   | 58808613 <b>NEUW</b> |
| 305                  | 3,2    | 2,5    | 30       | 96 | ▲▲▲            | Combi3 | -3            | 1                |   | 58808614 <b>NEUW</b> |

\* Snijkwaliteit ▲ Zeer grove snede, ▲▲ Grove snede, ▲▲▲ Fijne snede, ▲▲▲▲ Zeer fijne snede

\*\* Extra gaten: Combi1 komt overeen met 2/10/60 + 2/7/42 Combi2 komt overeen met 2/7/42 + 2/9/46 en 2/10/60 Combi3 = 2/10/60 + 2/9/46 + 2/9,5/46,5 + 2/7/42 Combi5 = 2/7/110 + 2/9/110 + 2/8,4/130 + 2/14/110 + 4/9/100 + 4/19/120 Combi7 = 2/9/110 + 2/10/80 + 2/11/85 + 2/11/115 + 2/11/148 + 2/14/100 + 2/14/125 + 2/19/120

Geschikte reduceerringen vindt u aan het einde van dit hoofdstuk

HW

KKO

Afkort-cirkelzaagbladen HW voor kantenbewerking zonder verzinking - wisseltand

Product



Tekening

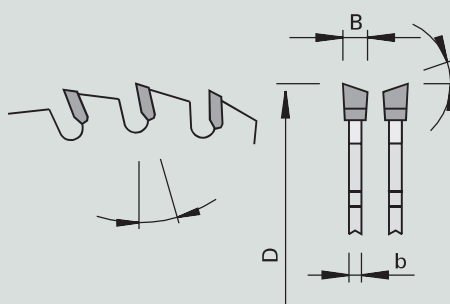

Machine



Toepassing



Uitvoering



3-0-1

HW  
TC06

WS

Machine / gebruiksaanwijzing

- Kantenaanlijmmachines
- Kantenbewerkingsautomaten
- Voor het afkorten van kantfineer op massief hout en fineer- en kunststofranden

Uitvoering

- Speciale NoNoise-spaanruimtegeometrie
- Spaanhoek positief of negatief
- Met of zonder ashoek
- Tandvorm: wisseltand 'WS'
- Snijmateriaal HW TC06

Voordelen

- Extreem geluidsarm
- Geluidsreducering met ca. 6 dB(A) bij stationair draaien

Informatie - Tip

Producteigenschappen

Bestelinformatie

| Ø D  | B    | b    | Ø d  | Z  | Snij-<br>kwaliteit* | NL**                   | Spaan-<br>hoek | Tand-<br>hoek | Ashoek |                     | VE    | V | Bestelnummer   |
|------|------|------|------|----|---------------------|------------------------|----------------|---------------|--------|---------------------|-------|---|--|
| [mm] | [mm] | [mm] | [mm] |    |                     |                        | [°]            | [°]           | [°]    |                     | [St.] |   |  |
| 90   | 3,0  | 2,0  | 30   | 20 | ▲▲                  |                        | 8              | 10            | 0      | Reich               | 1     |   | 58808800   |
| 100  | 2,4  | 1,6  | 22   | 12 | ▲                   |                        | 15             | 10            | 5      | HOLZ-HER            | 1     |   | 58808801   |
| 100  | 2,4  | 1,6  | 22   | 20 | ▲▲                  | 2/4/30                 | -8             | 10            | 5      | EBM                 | 1     |   | 58808802   |
| 100  | 3,2  | 2,2  | 22   | 20 | ▲▲▲                 |                        | 8              | 15            | 0      | Felder,<br>Lohmeyer | 1     |   | 58808836   |
| 100  | 2,6  | 1,6  | 32   | 30 | ▲▲                  |                        | 10             | 15            | 5      | Brandt              | 1     |   | 58808804   |
| 110  | 3,6  | 2,5  | 22   | 20 | ▲▲                  |                        | 8              | 30            | 5      | Reich               | 1     |   | 58808805   |
| 110  | 3,6  | 2,5  | 32   | 20 | ▲▲                  |                        | 8              | 30            | 5      | Homag               | 1     |   | 58808806   |
| 120  | 3,2  | 2,2  | 32   | 20 | ▲▲                  |                        | 10             | 10            | 5      | Homag               | 1     |   | 58808808   |
| 125  | 2,4  | 1,6  | 32   | 24 | ▲▲                  |                        | 15             | 30            | 0      | Brandt              | 1     |   | 58808835   |
| 140  | 3,2  | 2,2  | 16   | 36 | ▲▲▲                 |                        | 10             | 15            | 5      | Ott                 | 1     |   | 58808809   |
| 140  | 3,2  | 2,2  | 22   | 36 | ▲▲▲                 |                        | 10             | 15            | 5      | HOLZ-HER            | 1     |   | 58808810   |
| 150  | 3,2  | 2,2  | 22   | 48 | ▲▲▲                 |                        | 10             | 10            | 5      | IMA                 | 1     |   | 58808811   |
| 160  | 3,0  | 2,5  | 22   | 36 | ▲▲▲                 |                        | -5             | 15            | 5      | IMA                 | 1     |   | 58808843   |
| 160  | 3,5  | 2,5  | 22   | 36 | ▲▲▲                 |                        | -5             | 15            | 5      | IMA                 | 1     |   | 58808813 <span style="color: red; font-weight: bold;">NIEUW</span> |
| 160  | 3,2  | 2,2  | 20   | 48 | ▲▲▲                 | 2/5/32                 | 10             | 10            | 5      | HOLZ-HER            | 1     |   | 58808812   |
| 160  | 3,2  | 2,2  | 22   | 48 | ▲▲▲                 |                        | -8             | 10            | 5      | IMA                 | 1     |   | 58808814   |
| 160  | 3,2  | 2,2  | 30   | 24 | ▲▲                  | 2/7/42                 | 15             | 10            | 5      | HOLZ-HER            | 1     |   | 58808815   |
| 160  | 3,2  | 2,2  | 40   | 30 | ▲▲                  | 4/5,5/52               | -8             | 20            | 10     | HOLZ-HER            | 1     |   | 58808816   |
| 170  | 3,2  | 2,2  | 30   | 36 | ▲▲▲                 | 4/5,5/52               | 10             | 20            | 0      | Homag               | 1     |   | 58808817   |
| 200  | 3,2  | 2,2  | 30   | 64 | ▲▲▲                 | 4/6,6/60 +<br>2/6,2/42 | 10             | 15            | 0      | IMA                 | 1     |   | 58808818   |

\* Snijkwaliteit ▲ Zeer grove snede, ▲▲ Grove snede, ▲▲▲ Fijne snede, ▲▲▲▲ Zeer fijne snede





\*\* Extra gaten: Combi1 komt overeen met 2/10/60 + 2/7/42 Combi2 komt overeen met 2/7/42 + 2/9/46 en 2/10/60 Combi3 = 2/10/60 + 2/9/46 + 2/9,5/46,5 + 2/7/42 Combi5 = 2/7/110 + 2/9/110 + 2/8,4/130 + 2/14/110 + 4/9/100 + 4/19/120 Combi7 = 2/9/110 + 2/10/80 + 2/11/85 + 2/11/115 + 2/11/148 + 2/14/100 + 2/14/125 + 2/19/120

Geschikte reduceerringen vindt u aan het einde van dit hoofdstuk

HW

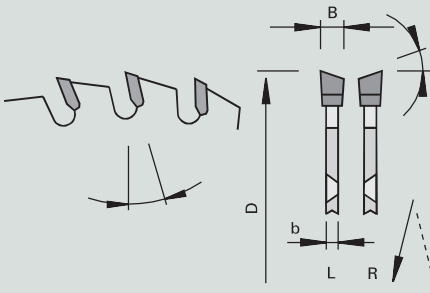
KKM

Afkort-cirkelzaagbladen HW voor kantenbewerking met verzinking - wisseltand

|  |  |  |
|--|--|--|
| <p>Product</p>  | <p>Tekening</p>  | <p>Machine</p>  <p>Toepassing</p>  <p>Uitvoering</p>  <p>3-0-1</p> <p>HW TC06</p> <p>WS</p> |
|--|--|--|

|  |   |   |  |
|--|---|---|--|
| <p>Machine / gebruiksaanwijzing</p> <ul style="list-style-type: none"> <li>• Kantenbewerkingsautomaten</li> <li>• Voor het afkorten van kantfijnere op massief hout en fineer- en kunststofranden</li> </ul> | <p>Uitvoering</p> <ul style="list-style-type: none"> <li>• Speciale NoNoise-spaanruimtegeometrie</li> <li>• Spaanhoek positief</li> <li>• Met of zonder ashoek</li> <li>• Meeneemgaten verzonken</li> <li>• Tandvorm: wisseltand 'WS'</li> <li>• Snijmateriaal HW TC06</li> </ul> | <p>Voordelen</p> <ul style="list-style-type: none"> <li>• Extreem geluidsarm</li> <li>• Geluidsreducering met ca. 6 dB(A) bij stationair draaien</li> </ul> | <p>Informatie - Tip</p> <ul style="list-style-type: none"> <li>• Δ = niet verzonken</li> <li>• Draairichting volgens DIN-EN 50144</li> </ul> |
|--|---|---|--|

| Producteigenschappen |      |      |      |    |                 |                    |            |           |        |                      | Bestelinformatie |       |   |              |
|----------------------|------|------|------|----|-----------------|--------------------|------------|-----------|--------|----------------------|------------------|-------|---|--------------|
| Ø D                  | B    | b    | Ø d  | Z  | Snij-kwaliteit* | NL**               | Spaan-hoek | Tand-hoek | Ashoek |                      | L                | VE    | V | Bestelnummer |
| [mm]                 | [mm] | [mm] | [mm] |    |                 |                    | [°]        | [°]       | [°]    |                      |                  | [St.] |   |              |
| 110                  | 3,2  | 2,5  | 40   | 20 | ▲▲▲             | 4/5,5/52           | 10         | 45        | 5      | Homag                | N                | 1     |   | 58808837     |
| 110                  | 3,2  | 2,5  | 40   | 20 | ▲▲▲             | 4/5,5/52           | 10         | 30        | 5      | Homag                | R                | 1     |   | 58808838     |
| 120                  | 3,2  | 2,5  | 40   | 36 | ▲▲▲             | 2x4/5,5/52         | 10         | 45        | 5      | Homag                | N                | 1     |   | 58808839     |
| 120                  | 3,6  | 2,8  | 40   | 24 | ▲▲              | 2x4/6/52           | 8          | 30        | 0      | Homag                | N                | 1     |   | 58808819     |
| 125                  | 2,4  | 1,6  | 30   | 36 | ▲▲▲             | 2x4/6,5/48         | 10         | 30        | 0      | Homag BAZ            | N                | 1     |   | 58808820     |
| 140                  | 3,2  | 2,2  | 30   | 36 | ▲▲▲             | 4/8,6/46           | 10         | 15        | 5      | Biesse Akron 600/800 | L                | 1     | ⊕ | 58808821     |
| 140                  | 3,2  | 2,2  | 30   | 36 | ▲▲▲             | 4/8,6/46           | 10         | 15        | 5      | Biesse Akron 600/800 | R                | 1     | ⊕ | 58808822     |
| 150                  | 3,2  | 2,2  | 30   | 48 | ▲▲▲             | 4/6/48 + Δ4/5,5/52 | 10         | 15        | 0      | Homag BAZ            | R                | 1     |   | 58808823     |
| 180                  | 3,2  | 2,2  | 30   | 54 | ▲▲▲             | 4/6/52             | 10         | 30        | 5      | Homag BAZ            | L                | 1     |   | 58808824     |
| 150                  | 3,6  | 2,8  | 40   | 30 | ▲▲▲             | 4/6/52             | 8          | 30        | 0      | Biesse Akron 600/800 | N                | 1     |   | 58808840     |

\* Snijkwaliteit ▲ Zeer grove snede, ▲▲ Grove snede, ▲▲▲ Fijne snede, ▲▲▲▲ Zeer fijne snede

\*\* Extra gaten: Combi1 komt overeen met 2/10/60 + 2/7/42 Combi2 komt overeen met 2/7/42 + 2/9/46 en 2/10/60 Combi3 = 2/10/60 + 2/9/46 + 2/9,5/46,5 + 2/7/42 Combi5 = 2/7/110 + 2/9/110 + 2/8,4/130 + 2/14/110 + 4/9/100 + 4/19/120 Combi7 = 2/9/110 + 2/10/80 + 2/11/85 + 2/11/115 + 2/11/148 + 2/14/100 + 2/14/125 + 2/19/120

Geschikte reduceerringen vindt u aan het einde van dit hoofdstuk



HW

KKE

Afkort-cirkelzaagbladen HW voor kantenbewerking zonder verzinking - eenzijdig-spits

Product



Tekening

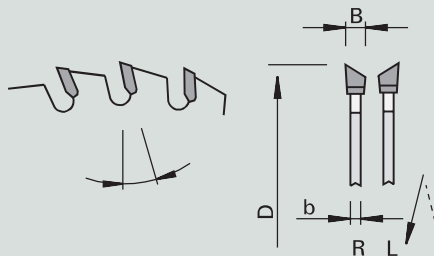

Machine



Toepassing



Uitvoering



Machine / gebruiksaanwijzing

- Kantenaanlijmmachines
- Kantenbewerkingsautomaten
- Voor het afkorten van dunne kantfijner op massief hout en fijneeren kunststofranden

Uitvoering

- Speciale NoNoise-spaanruimte-geometrie
- Spaanhoek positief of negatief
- Met en zonder ashoek
- Tandvorm: eenzijdig spits 'ES' (rechts + links)\*
- Snijmateriaal HW TC06

Voordelen

- Extreem geluidsarm
- Geluidsreducering met ca. 6 dB(A) bij stationair draaien

Informatie - Tip

- Draairichting zie tekening

Producteigenschappen

Bestelinformatie

| Ø D  | B    | b    | Ø d  | Z  | Snij-<br>kwaliteit* | NL**     | Spaan-<br>hoek | Tand-<br>hoek | Ashoek |                    | L | VE    | V | Bestelnummer |
|------|------|------|------|----|---------------------|----------|----------------|---------------|--------|--------------------|---|-------|---|--------------|
| [mm] | [mm] | [mm] | [mm] |    |                     |          | [°]            | [°]           | [°]    |                    |   | [St.] |   |              |
| 100  | 2,6  | 2,0  | 32   | 30 | ▲▲                  |          | -10            | 15            | 0      | Brandt             | L | 1     |   | 58808829     |
| 100  | 2,6  | 2,0  | 32   | 30 | ▲▲                  |          | -10            | 15            | 0      | Brandt             | R | 1     |   | 58808830     |
| 100  | 2,6  | 2,0  | 32   | 30 | ▲▲                  |          | 10             | 15            | 0      | Homag CN           | R | 1     |   | 58808841     |
| 100  | 2,6  | 2,0  | 32   | 30 | ▲▲                  |          | 10             | 15            | 0      | Homag CN           | L | 1     |   | 58808842     |
| 100  | 2,6  | 1,6  | 32   | 30 | ▲▲                  |          | 10             | 10            | 0      | Brandt             | L | 1     |   | 58808831     |
| 100  | 2,6  | 1,6  | 32   | 30 | ▲▲                  |          | 10             | 10            | 0      | Brandt             | R | 1     |   | 58808832     |
| 150  | 3,5  | 2,2  | 30   | 44 | ▲▲▲                 | 4/5,5/52 | -12            | 45            | 10     | Homag<br>Powerline | L | 1     |   | 58808833     |
| 150  | 3,5  | 2,2  | 30   | 44 | ▲▲▲                 | 4/5,5/52 | -12            | 45            | 10     | Homag<br>Powerline | R | 1     |   | 58808834     |

\* Snijkwaliteit ▲ Zeer grove snede, ▲▲ Grove snede, ▲▲▲ Fijne snede, ▲▲▲▲ Zeer fijne snede

\*\* Extra gaten: Combi1 komt overeen met 2/10/60 + 2/7/42 Combi2 komt overeen met 2/7/42 + 2/9/46 en 2/10/60 Combi3 = 2/10/60 + 2/9/46 + 2/9,5/46,5 + 2/7/42 Combi5 = 2/7/110 + 2/9/110 + 2/8,4/130 + 2/14/110 + 4/9/100 + 4/19/120 Combi7 = 2/9/110 + 2/10/80 + 2/11/85 + 2/11/115 + 2/11/148 + 2/14/100 + 2/14/125 + 2/19/120

Geschikte reduceerringen vindt u aan het einde van dit hoofdstuk

## Reduceerringen - gekarteld

Voor cirkelzaagbladen

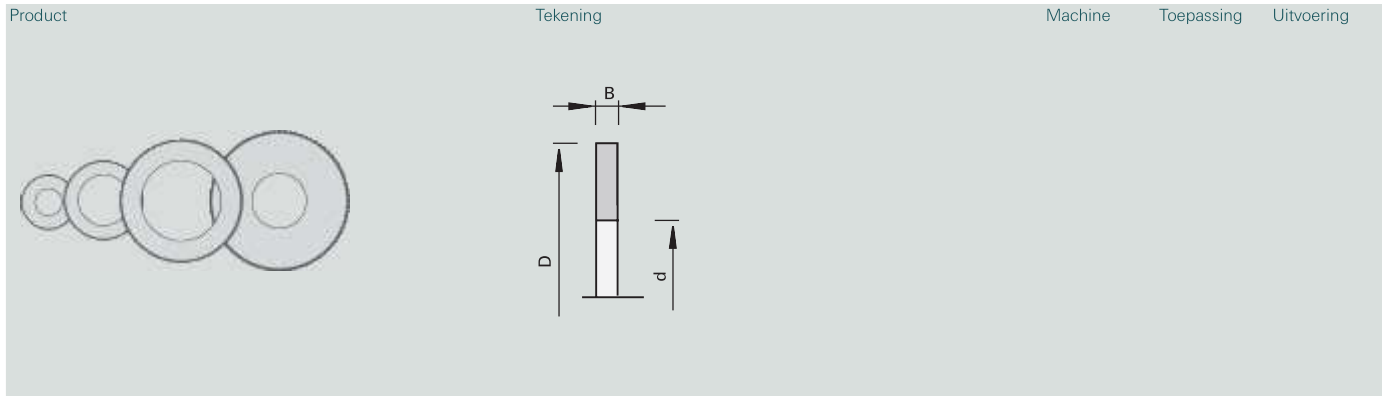

| Machine / gebruiksaanwijzing  | Uitvoering  | Voordelen | Informatie - Tip   |
|---|---|-----------|--|
| <ul style="list-style-type: none"> <li>• Handcirkelzaagbladen</li> <li>• Voor asgat reductie</li> </ul> | <ul style="list-style-type: none"> <li>• Geslepen asgat</li> <li>• Uitwendig vertand</li> </ul> |           | <ul style="list-style-type: none"> <li>• Het asgat kan alleen gereduceerd worden wanneer de opspanning van het zaagblad door spanningen of dmv flens gewaarborgd is</li> </ul> |

| Producteigenschappen |        |          | Bestelinformatie |                |
|----------------------|--------|----------|------------------|----------------|
| Ø D [mm]             | B [mm] | Ø d [mm] | VE [St.]         | V Bestelnummer |
| 20                   | 1,4    | 12,7     | 1                | 50880032       |
| 20                   | 1,4    | 13       | 1                | 50880029       |
| 20                   | 1,8    | 15       | 1                | 50880018       |
| 20                   | 1,4    | 16       | 1                | 50880027       |
| 20                   | 1,6    | 16       | 1                | 50880050       |
| 20                   | 1,8    | 16       | 1                | 50880016       |
| 22                   | 2,0    | 20       | 1                | 50880036       |
| 25                   | 1,4    | 16       | 1                | # 50880039     |
| 25                   | 1,4    | 20       | 1                | 50880038       |
| 25                   | 2,2    | 22       | 10               | s 50880159     |
| 25,4                 | 2,0    | 20       | 1                | 50882620       |
| 30                   | 2,0    | 15       | 1                | 50880014       |
| 30                   | 1,4    | 16       | 1                | 50880031       |
| 30                   | 2,0    | 16       | 1                | 50880044       |
| 30                   | 2,2    | 16       | 1                | 50880012       |
| 30                   | 1,8    | 18       | 1                | 50883018       |
| 30                   | 1,4    | 20       | 1                | 50880026       |
| 30                   | 2,0    | 20       | 1                | 50880045       |
| 30                   | 2,2    | 20       | 1                | 50880010       |
| 30                   | 2,0    | 22       | 1                | 50880033       |
| 30                   | 2,0    | 22,2     | 1                | 50883022       |
| 30                   | 2,0    | 24       | 1                | 50880009       |
| 30                   | 1,4    | 25       | 1                | 50880008       |
| 30                   | 2,0    | 25       | 1                | 50880042       |
| 30                   | 2,2    | 25       | 1                | 50880007       |
| 30                   | 2,0    | 25,4     | 1                | 50880006       |
| 32                   | 2,0    | 20       | 1                | 50883220       |
| 32                   | 2,2    | 25       | 1                | 50880139       |
| 32                   | 2,0    | 30       | 10               | s 50883230     |
| 32                   | 2,2    | 30       | 1                | 50880004       |
| 35                   | 1,8    | 25       | 10               | s 50883525     |
| 35                   | 2,0    | 20       | 1                | # 50883520     |
| 35                   | 1,8    | 30       | 1                | 50883530       |
| 35                   | 2,0    | 30       | 1                | 50880040       |
| 40                   | 2,2    | 30       | 1                | 50880001       |

\* Snijkwaliteit ▲ Zeer grove snede, ▲▲ Grove snede, ▲▲▲ Fijne snede, ▲▲▲▲ Zeer fijne snede

\*\* Extra gaten: Combi1 komt overeen met 2/10/60 + 2/7/42 Combi2 komt overeen met 2/7/42 + 2/9/46 en 2/10/60 Combi3 = 2/10/60 + 2/9/46 + 2/9,5/46,5 + 2/7/42 Combi5 = 2/7/110 + 2/9/110 + 2/8,4/130 + 2/14/110 + 4/9/100 + 4/19/120 Combi7 = 2/9/110 + 2/10/80 + 2/11/85 + 2/11/115 + 2/11/148 + 2/14/100 + 2/14/125 + 2/19/120

Geschikte reduceerringen vindt u aan het einde van dit hoofdstuk

| Omschrijving                  | Bestaande uit   |          | VE [St.] | V | Bestelnummer |
|-------------------------------|-----------------|----------|----------|---|--------------|
| Reduceerringen-set (50 stuks) | 5 x 20/13,0/1,4 | 50880029 | 1        | # | 50881001     |
|                               | 5 x 20/16,0/1,6 | 50880050 |          |   |              |
|                               | 5 x 30/16,0/1,4 | 50880031 |          |   |              |
|                               | 5 x 30/16,0/2,0 | 50880044 |          |   |              |
|                               | 5 x 30/20,0/1,4 | 50880026 |          |   |              |
|                               | 5 x 30/20,0/2,0 | 50880045 |          |   |              |
|                               | 5 x 30/25,0/1,4 | 50880008 |          |   |              |
|                               | 5 x 30/25,0/2,0 | 50880042 |          |   |              |
|                               | 5 x 30/25,4/2,0 | 50880006 |          |   |              |
|                               | 5 x 32/30,0/2,2 | 50880004 |          |   |              |

## Reduceerringen - vlak

Voor cirkelzaagbladen

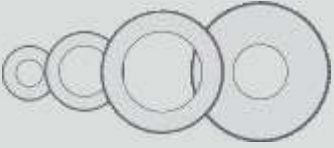
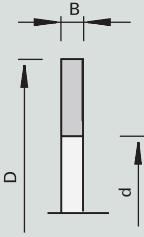
| Product   | Tekening  | Machine | Toepassing | Uitvoering |
|---|---|---------|------------|------------|
|  |  |         |            |            |

| Machine / gebruiksaanwijzing  | Uitvoering   | Voordelen | Informatie - Tip   |
|---|--|-----------|--|
| <ul style="list-style-type: none"> <li>• Handcirkelzaagbladen</li> <li>• Voor asgat reductie</li> </ul> | <ul style="list-style-type: none"> <li>• Geslepen asgat</li> <li>• Uitwendig vlak</li> </ul> |           | <ul style="list-style-type: none"> <li>• Het asgat kan alleen gereduceerd worden wanneer de opspanning van het zaagblad door spanningen of dmv flens gewaarborgd is</li> </ul> |

| Producteigenschappen |        |          |            | Bestelinformatie |   |              |
|----------------------|--------|----------|------------|------------------|---|--------------|
| Ø D [mm]             | B [mm] | Ø d [mm] | Ø d [inch] | VE [St.]         | V | Bestelnummer |
| 20                   | 1,6    | 12,7     | 1/2"       | 1                |   | 161946       |
| 20                   | 1,6    | 16       |            | 1                |   | 161945       |
| 22                   | 2,0    | 20       |            | 1                |   | 161887       |
| 22                   | 4,0    | 20       |            | 1                |   | 161830       |
| 25                   | 2,2    | 20       |            | 1                |   | 000104       |
| 30                   | 1,4    | 15       |            | 1                | s | 000107       |
| 30                   | 1,4    | 16       |            | 1                |   | 000111       |
| 30                   | 1,4    | 20       |            | 1                |   | 000117       |
| 30                   | 1,4    | 25       |            | 1                |   | 000125       |
| 30                   | 1,8    | 15,1     | 19/32"     | 1                | # | 161949       |
| 30                   | 1,9    | 16       |            | 1                |   | 000112       |
| 30                   | 1,9    | 20       |            | 1                |   | 000118       |
| 30                   | 2,0    | 20       |            | 1                |   | 016848       |
| 30                   | 2,0    | 25       |            | 1                | s | 000127       |
| 30                   | 2,2    | 15,88    | 5/8"       | 1                | s | 000110       |
| 30                   | 2,2    | 16       |            | 1                |   | 000113       |
| 30                   | 2,2    | 18       |            | 1                |   | 000114       |
| 30                   | 2,2    | 20       |            | 1                |   | 000119       |
| 30                   | 2,2    | 22       |            | 1                |   | 000120       |
| 30                   | 2,2    | 25       |            | 1                |   | 000128       |
| 30                   | 2,2    | 25,4     | 1"         | 1                |   | 000130       |
| 30                   | 2,2    | 28       |            | 1                |   | 000132       |
| 30                   | 3,0    | 25       |            | 1                |   | 000129       |
| 32                   | 2,0    | 16       |            | 1                |   | 161886       |
| 32                   | 2,2    | 16       |            | 1                | s | 000134       |
| 32                   | 2,2    | 20       |            | 1                | s | 000135       |
| 32                   | 2,2    | 22       |            | 1                |   | 010571       |
| 32                   | 2,2    | 30       |            | 1                |   | 000137       |

\* **Snijkwaliteit** ▲ Zeer grove snede, ▲▲ Grove snede, ▲▲▲ Fijne snede, ▲▲▲▲ Zeer fijne snede

\*\* **Extra gaten:** **Combi1** komt overeen met 2/10/60 + 2/7/42 **Combi2** komt overeen met 2/7/42 + 2/9/46 en 2/10/60 **Combi3** = 2/10/60 + 2/9/46 + 2/9,5/46,5 + 2/7/42 **Combi5** = 2/7/110 + 2/9/110 + 2/8,4/130 + 2/14/110 + 4/9/100 + 4/19/120 **Combi7** = 2/9/110 + 2/10/80 + 2/11/85 + 2/11/115 + 2/11/148 + 2/14/100 + 2/14/125 + 2/19/120

Geschikte **reduceerringen** vindt u aan het einde van dit hoofdstuk

| Producteigenschappen |           |             |               | Bestelinformatie |   |              |
|----------------------|-----------|-------------|---------------|------------------|---|--------------|
| Ø D<br>[mm]          | B<br>[mm] | Ø d<br>[mm] | Ø d<br>[inch] | VE<br>[St.]      | V | Bestelnummer |
| 35                   | 1,0       | 30          |               | 1                |   | 000145       |
| 35                   | 1,4       | 30          |               | 1                | s | 000146       |
| 35                   | 1,9       | 30          |               | 1                |   | 000147       |
| 35                   | 2,2       | 20          |               | 1                |   | 000138       |
| 35                   | 2,2       | 24          |               | 1                | s | 000139       |
| 35                   | 2,2       | 25          |               | 1                |   | 000142       |
| 35                   | 2,2       | 30          |               | 1                |   | 000148       |
| 40                   | 2,0       | 32          |               | 1                |   | 161962       |
| 40                   | 2,2       | 20          |               | 1                |   | 000151       |
| 40                   | 2,2       | 30          |               | 1                |   | 000153       |
| 40                   | 2,2       | 35          |               | 1                | s | 000154       |
| 45                   | 2,5       | 30          |               | 1                |   | 161831       |
| 50                   | 2,2       | 30          |               | 1                |   | 000156       |
| 55                   | 2,2       | 30          |               | 1                |   | 000159       |
| 60                   | 2,2       | 30          |               | 1                |   | 000161       |
| 60                   | 2,2       | 35          |               | 1                |   | 000162       |
| 60                   | 2,2       | 40          |               | 1                | s | 000163       |
| 60                   | 2,2       | 50          |               | 1                |   | 000164       |
| 60                   | 2,8       | 30          |               | 1                |   | 010577       |
| 70                   | 2,2       | 30          |               | 1                | s | 000166       |
| 80                   | 2,2       | 30          |               | 1                |   | 000171       |
| 80                   | 2,2       | 35          |               | 1                | s | 000172       |
| 80                   | 2,2       | 50          |               | 1                | s | 000175       |
| 80                   | 2,2       | 60          |               | 1                | s | 000177       |
| 80                   | 2,2       | 70          |               | 1                | s | 000179       |
| 80                   | 2,8       | 60          |               | 1                | s | 000178       |

\* Snijkwaliteit ▲ Zeer grove snede, ▲▲ Grove snede, ▲▲▲ Fijne snede, ▲▲▲▲ Zeer fijne snede

\*\* Extra gaten: Combi1 komt overeen met 2/10/60 + 2/7/42 Combi2 komt overeen met 2/7/42 + 2/9/46 en 2/10/60 Combi3 = 2/10/60 + 2/9/46 + 2/9.5/46.5 + 2/7/42 Combi5 = 2/7/110 + 2/9/110 + 2/8.4/130 + 2/14/110 + 4/9/100 + 4/19/120 Combi7 = 2/9/110 + 2/10/80 + 2/11/85 + 2/11/115 + 2/11/148 + 2/14/100 + 2/14/125 + 2/19/120

Geschikte reduceerringen vindt u aan het einde van dit hoofdstuk



# FREESGEREEDSCHAPPEN MET ASGAT

## Inhoud

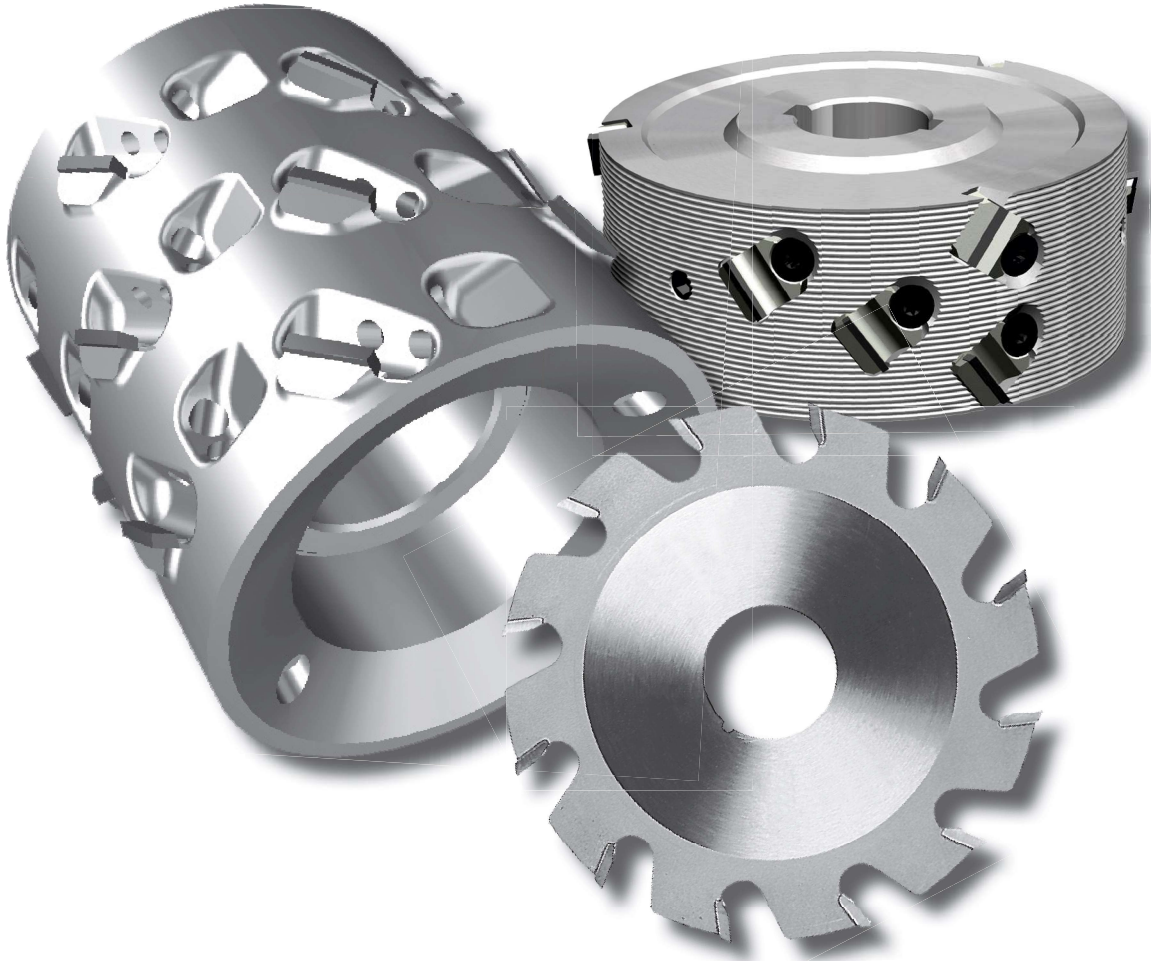

|                      |      |
|----------------------|------|
| Groeffrezen          | 2-1  |
| Voegen/strijken/fase | 2-11 |
| Kantbewerking        | 2-18 |
| Profileren           | 2-20 |
| Contra-profileren    | 2-23 |
| Verlijmen            | 2-25 |
| Schaafwerk           | 2-28 |

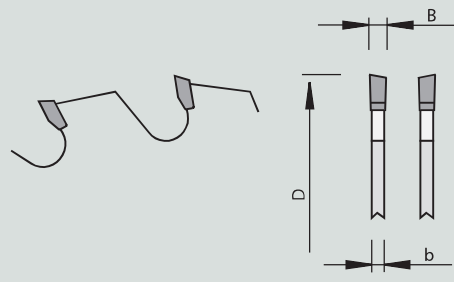



## HW 1103L Groeffrees - voor Lamello®

|   |  |   |   |   |
|---|--|---|---|---|
| Product   | Tekening   | Machine   | Toepassing  | Uitvoering  |
|  |  |  |  | <ul style="list-style-type: none"> <li>HW TC06</li> <li>HW TC10</li> <li>WS</li> <li>WS-DU</li> </ul> |

|   |  |           |  |
|---|--|-----------|--|
| Machine / gebruiksaanwijzing  | Uitvoering   | Voordelen | Informatie - Tip   |
| <ul style="list-style-type: none"> <li>Machines Lamello®, ELU</li> <li>Voor het braamvrij groeffrezen van Lamello®-houtverbindingen bij massief hout en plaatmateriaal op basis van hout</li> </ul> | <ul style="list-style-type: none"> <li>Tandvorm: wisseltand 'WS'</li> <li>Tandvorm bij 50660300: wisseltand - Duplovtand 'WS-DU'</li> <li>Snijmateriaal: HW TC06</li> <li>Snijmateriaal bij 50110178: HW TC10</li> </ul> |           | <ul style="list-style-type: none"> <li>Toepassing: tegenlopende bewerkingen</li> </ul> |

| Producteigenschappen |        |        |          |    |          |                   | Bestelinformatie |   |   |              |
|----------------------|--------|--------|----------|----|----------|-------------------|------------------|---|---|--------------|
| Ø D [mm]             | B [mm] | b [mm] | Ø d [mm] | Z  | NL**     | nmin-nmax [min-1] |                  | VE [St.]  | V | Bestelnummer |
| 100                  | 4,0    | 3,45   | 22       | 6  | 4/4,5/36 | 7600-13000        | Lamello®         |    | 1 | 50660300     |
| 100                  | 3,97   | 2,8    | 22       | 12 |          | 7500-13100        | Lamello®         |  | 1 | 50110178     |
| 102                  | 3,85   | 3,0    | 22       | 12 |          | 7500-13100        | ELU DS 140       |  | 1 | 50660301     |

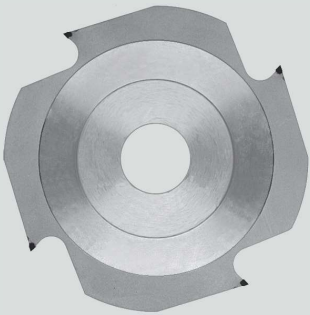
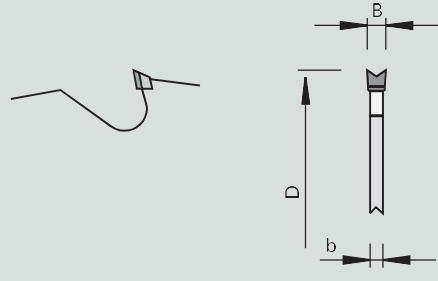
## DP 3103L Groeffrees - voor Lamello®

|   |  |   |   |            |
|---|--|---|---|------------|
| Product   | Tekening   | Machine   | Toepassing  | Uitvoering |
|  |  |  |  |            |

|  |   |           |  |
|--|---|-----------|--|
| Machine / gebruiksaanwijzing   | Uitvoering  | Voordelen | Informatie - Tip   |
| <ul style="list-style-type: none"> <li>Machines Lamello®</li> <li>Voor het braamvrij groeffrezen van Lamello®-houtverbindingen bij massief hout en plaatmateriaal op basis van hout</li> </ul> | <ul style="list-style-type: none"> <li>Gereduceerde naslijpzone</li> <li>Tandvorm: concaaf</li> <li>n = 7.700 - 13.300 min-1</li> </ul> |           | <ul style="list-style-type: none"> <li>Toepassing: tegenlopende bewerkingen</li> <li>Als groeffrees bruikbaar op CNC-machines</li> </ul> |

| Producteigenschappen |        |        |          |   |  |  | Bestelinformatie  |   |              |  |
|----------------------|--------|--------|----------|---|--|--|---|---|--------------|--|
| Ø D [mm]             | B [mm] | b [mm] | Ø d [mm] | Z |  |  | VE [St.]  | V | Bestelnummer |  |
| 100                  | 3,95   | 4,0    | 22       | 4 |  |  |  | 1 | 50660302     |  |

## DP 3140L Groeffrees voor Lamello Clamex P®

Product



Tekening

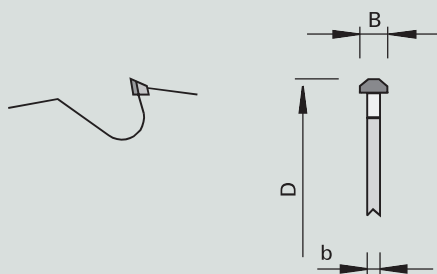

Machine



Toepassing



Uitvoering



Machine / gebruiksaanwijzing

- CNC-bewerkingscentra
- Voor het braamvrij groeffrezen voor Lamello Clamex P®-verbindingen in massief hout en plaatmateriaal op basis van hout

Uitvoering

- Niet naslijpbaar
- Tandvorm: specifiek
- n max = 15.200 min-1

Voordelen

Informatie - Tip

- Toepassing: tegenlopende bewerkingen
- Als groeffrees te gebruiken op CNC-machines

Producteigenschappen

| Ø D [mm] | B [mm] | b [mm] | Ø d [mm] | Z |  |     | VE [St.] | V | Bestelnummer         |
|----------|--------|--------|----------|---|--|-----|----------|---|----------------------|
| 100.4    | 7.0    | 4      | 22       | 3 |  | MAN | 1        |   | 50660347 <b>NIUW</b> |
| 100.4    | 7.0    | 4      | 30       | 3 |  |     | 1        |   | 50660346 <b>NIUW</b> |

Bestelinformatie

## HW 1568 Keermessen groeffrees – Silverline – voor Lamello®

Product



Tekening

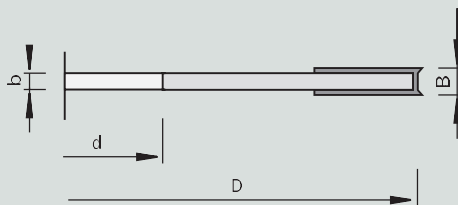

Machine



Toepassing



Uitvoering



Machine / gebruiksaanwijzing

- Machines Lamello®
- Voor het braamvrij groeffrezen voor Lamello®-houtverbindingen in massief hout en plaatmateriaal op basis van hout

Uitvoering

- n = 7.900 - 11.400 min-1

Voordelen

- 4 snijkanten



Informatie - Tip

- Toepassing: tegenlopende bewerkingen
- Meeneemgaten: verzinking aan één zijde Ø 9 mm

Producteigenschappen

| Ø D [mm]               | B [mm] | b [mm] | Ø d [mm] | Z    | NL**     |                              | VE [St.] | V      | Bestelnummer  |          |              |              |
|------------------------|--------|--------|----------|------|----------|------------------------------|----------|--------|---------------|----------|--------------|--------------|
| 100                    | 3,97   | 3,97   | 22       | 4 V4 | 4/4,5/36 |                              | 1        | o      | 69470022      |          |              |              |
| Omkeermessen           |        |        |          |      |          | B [mm]                       | H [mm]   | S [mm] | Snijmateriaal | VE [St.] | V            | Bestelnummer |
| Omkeermessen           |        |        |          |      |          | 18                           | 18       | 1.95   | TCw20         | 10       |              | 50450220     |
| Voorsnijder            |        |        |          |      |          | 14                           | 14       | 1.2    | TCw30         | 10       |              | 50450182     |
| Toebehoren             |        |        |          |      |          | Afmeting [mm]                |          |        | VE [St.]      | V        | Bestelnummer |              |
| Verzonken kopschroeven |        |        |          |      |          | M4x0,5x3,2 T9                |          |        | 10            |          | 163925       |              |
| Speciaalmoeren         |        |        |          |      |          | Voor WPL M4x0,5x2,2          |          |        | 10            |          | 163703       |              |
| Schroevendraaier       |        |        |          |      |          | T9                           |          |        | 1             |          | 164344       |              |
| Speciaalmoeren         |        |        |          |      |          | Voor voorsnijders M4x0,5x1,6 |          |        | 10            |          | 163704       |              |

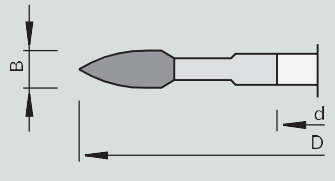
## HW 1103G Harsgalfrees

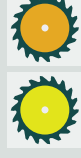
|  |   |  |   |                   |
|--|---|--|---|-------------------|
| <p>Product</p>  | <p>Tekening</p>  | <p>Machine</p>  | <p>Toepassing</p>  | <p>Uitvoering</p> |
|--|---|--|---|-------------------|

|  |  |                  |   |
|--|--|------------------|---|
| <p>Machine / gebruiksaanwijzing</p> <ul style="list-style-type: none"> <li>• Mini-Spot freesmachines</li> <li>• Voor het uitfrezen van harsgallen in massief hout</li> </ul> | <p>Uitvoering</p> <ul style="list-style-type: none"> <li>• HM scherend uitgevoerd</li> <li>• n max = 12.000 min-1</li> </ul> | <p>Voordelen</p> | <p>Informatie - Tip</p> <ul style="list-style-type: none"> <li>• Voor herstelmaten 1 - 4</li> </ul> |
|--|--|------------------|---|

| Producteigenschappen |        |          |   |          | Bestelinformatie  |   |              |
|----------------------|--------|----------|---|----------|---|---|--------------|
| Ø D [mm]             | B [mm] | Ø d [mm] | Z | NL**     | VE [St.]  | V | Bestelnummer |
| 100                  | 8,0    | 22       | 4 | 4/4,3/36 |  | 1 | 50621077     |



# HW 1101 Groefzaagblad

Product



Tekening

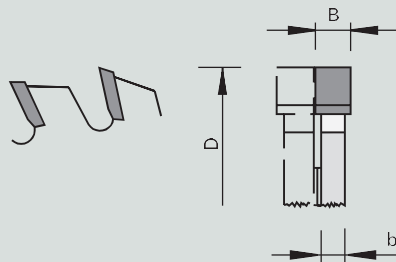

Machine



Toepassing



Uitvoering



Machine / gebruiksaanwijzing

- Tafelfreesmachines
- Voor het braamvrij groeffrezen in massief hout en plaatmateriaal op basis van hout

Uitvoering

- Tandvorm: vlakland "F"
- Snijmateriaal HW

Voordelen

Informatie - Tip

- Toepassing tegenlopend schulpen (massief hout)
- Toepassing meelopend alleen met mechanische aanzet (plaatmateriaal op basis van hout)
- Andere groefbreedtes mogelijk door setsamenstelling
- Groefbreedteberekening bij combigereedschappen: Som van alle "b" + HW-uitsteekmaat links en rechts + tussenringdikte

Producteigenschappen



Bestelinformatie

| Ø D [mm] | B [mm] | b [mm] | Ø d [mm] | Z  |     | nmin-nmax [min <sup>-1</sup> ] |  | VE [St.] | V | Bestelnummer |
|----------|--------|--------|----------|----|-----|--------------------------------|--|----------|---|--------------|
| 125      | 1,5    | 0,8    | 30       | 12 | MAN | 6100-10500                     |  | 1        |   | 50188359     |
| 125      | 1,8    | 1,0    | 30       | 12 | MAN | 6100-10500                     |  | 1        |   | 50188360     |
| 125      | 2,0    | 1,2    | 30       | 12 | MAN | 6100-10500                     |  | 1        |   | 50188361     |
| 125      | 2,2    | 1,2    | 30       | 12 | MAN | 6100-10500                     |  | 1        |   | 50188362     |
| 125      | 2,5    | 1,4    | 30       | 12 | MAN | 6100-10500                     |  | 1        |   | 50188363     |
| 125      | 3,0    | 2,0    | 30       | 12 | MAN | 6100-10500                     |  | 1        |   | 50188364     |
| 125      | 3,5    | 2,5    | 30       | 12 | MAN | 6100-10500                     |  | 1        |   | 50188365     |
| 125      | 4,0    | 2,5    | 30       | 12 | MAN | 6100-10500                     |  | 1        |   | 50188366     |
| 125      | 4,5    | 3,0    | 30       | 12 | MAN | 6100-10500                     |  | 1        |   | 50188367     |
| 125      | 5,0    | 4,0    | 30       | 12 | MAN | 6100-10500                     |  | 1        |   | 50188368     |
| 125      | 6,0    | 4,0    | 30       | 12 | MAN | 6100-10500                     |  | 1        |   | 50188369     |
| 125      | 7,0    | 5,0    | 30       | 12 | MAN | 6100-10500                     |  | 1        |   | 50188370     |
| 125      | 8,0    | 5,0    | 30       | 12 | MAN | 6100-10500                     |  | 1        |   | 50188371     |
| 125      | 10     | 6,0    | 30       | 12 | MAN | 6100-10500                     |  | 1        |   | 50188372     |
| 150      | 1,5    | 0,8    | 30       | 12 | MAN | 5200-8800                      |  | 1        |   | 50188373     |
| 150      | 2,0    | 1,2    | 30       | 12 | MAN | 5200-8800                      |  | 1        |   | 50188375     |
| 150      | 2,2    | 1,2    | 30       | 12 | MAN | 5200-8800                      |  | 1        |   | 50188376     |
| 150      | 2,5    | 1,5    | 30       | 12 | MAN | 5200-8800                      |  | 1        |   | 50188377     |
| 150      | 3,0    | 2,0    | 30       | 12 | MAN | 5200-8800                      |  | 1        |   | 50188378     |
| 150      | 3,5    | 2,5    | 30       | 12 | MAN | 5200-8800                      |  | 1        |   | 50188379     |
| 150      | 4,0    | 3,0    | 30       | 12 | MAN | 5200-8800                      |  | 1        |   | 50188380     |
| 150      | 4,5    | 3,5    | 30       | 12 | MAN | 5200-8800                      |  | 1        |   | 50188381     |
| 150      | 5,0    | 4,0    | 30       | 12 | MAN | 5200-8800                      |  | 1        |   | 50188382     |
| 150      | 6,0    | 4,0    | 30       | 12 | MAN | 5200-8800                      |  | 1        |   | 50188383     |
| 150      | 7,0    | 5,0    | 30       | 12 | MAN | 5200-8800                      |  | 1        |   | 50188384     |
| 150      | 8,0    | 5,0    | 30       | 12 | MAN | 5200-8800                      |  | 1        |   | 50188385     |
| 150      | 9,0    | 6,0    | 30       | 12 | MAN | 5200-8800                      |  | 1        |   | 50188386     |
| 150      | 10     | 6,0    | 30       | 12 | MAN | 5200-8800                      |  | 1        |   | 50188387     |

**HW**

**NK**

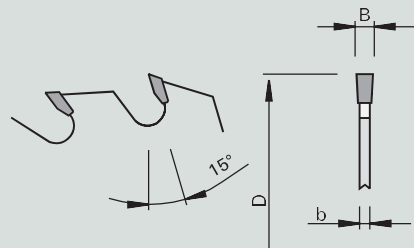
**Groefzaagblad HW - vlakland**

|  |  |  |   |   |         |     |   |
|--|--|--|---|---|---------|-----|---|
| <p>Product</p>  | <p>Tekening</p>  | <p>Machine</p>  | <p>Toepassing</p>  | <p>Uitvoering</p> <table border="1"> <tr><td>HW TC06</td></tr> <tr><td>MEC</td></tr> <tr><td>F</td></tr> </table> | HW TC06 | MEC | F |
| HW TC06  |  |  |   |   |         |     |   |
| MEC  |  |  |   |   |         |     |   |
| F  |  |  |   |   |         |     |   |



|  |  |                  |  |
|--|--|------------------|--|
| <p>Machine / gebruiksaanwijzing</p> <ul style="list-style-type: none"> <li>• Stationaire machine</li> <li>• Formaatbewerkingsmachine</li> <li>• Voor het groeven zagen in massief hout en plaatmaterialen</li> </ul> | <p>Uitvoering</p> <ul style="list-style-type: none"> <li>• Tandvorm: vlakland "F"</li> <li>• Tandbezetting: HW TC06</li> </ul> | <p>Voordelen</p> | <p>Informatie - Tip</p> <ul style="list-style-type: none"> <li>• Bij Z=12 en Z=18 is door een andere setsamenstelling een grotere groefbreedte mogelijk</li> <li>• Groefbreedteberekening bij combigereedschappen: Som van alle 'b' + HW-uitsteekmaat links en rechts + tussenringdikte</li> </ul> |
|--|--|------------------|--|

| Producteigenschappen |        |        |          |    |                |               |    | Bestelinformatie |   |              |
|----------------------|--------|--------|----------|----|----------------|---------------|----|------------------|---|--------------|
| Ø D [mm]             | B [mm] | b [mm] | Ø d [mm] | Z  | Snijkwaliteit* | Spaanhoek [°] |    | VE [St.]         | V | Bestelnummer |
| 180                  | 4,0    | 3,0    | 30       | 18 | ▲▲▲            | MEC           | 15 |                  | 1 | 50169685     |
| 180                  | 5,0    | 4,0    | 30       | 18 | ▲▲▲            | MEC           | 15 |                  | 1 | 50169684     |
| 180                  | 8,0    | 5,0    | 30       | 18 | ▲▲▲            | MEC           | 15 |                  | 1 | 50169683     |
| 180                  | 10     | 6,0    | 30       | 18 | ▲▲▲            | MEC           | 15 |                  | 1 | 50169682     |

**HW**

**NKP**

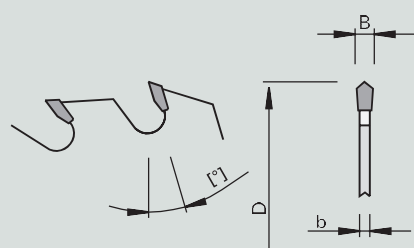
**Groefzaagblad - Prisma HW - V - tand**

|  |  |  |   |   |         |
|--|--|--|---|---|---------|
| <p>Product</p>  | <p>Tekening</p>  | <p>Machine</p>  | <p>Toepassing</p>  | <p>Uitvoering</p> <table border="1"> <tr><td>HW TC10</td></tr> </table> | HW TC10 |
| HW TC10  |  |  |   |   |         |

|   |   |                  |  |
|---|---|------------------|--|
| <p>Machine / gebruiksaanwijzing</p> <ul style="list-style-type: none"> <li>• Machines Lamello®, handcirkelzaagbladen</li> <li>• Voor het V-groeffrezen in massief hout en plaatmateriaal op basis van hout, langssnede</li> </ul> | <p>Uitvoering</p> <ul style="list-style-type: none"> <li>• Tandvorm prisma 'V'</li> <li>• Snijmateriaal HW TC10</li> <li>• Tophoek 90 graden</li> </ul> | <p>Voordelen</p> | <p>Informatie - Tip</p> <ul style="list-style-type: none"> <li>• Toepassing tegenlopend schulpen (massief hout)</li> </ul> |
|---|---|------------------|--|

| Producteigenschappen |        |        |          |    |     |                   |  | Bestelinformatie |   |              |
|----------------------|--------|--------|----------|----|-----|-------------------|--|------------------|---|--------------|
| Ø D [mm]             | B [mm] | b [mm] | Ø d [mm] | Z  |     | nmin-nmax [min-1] |  | VE [St.]         | V | Bestelnummer |
| 100                  | 7,0    | 5,0    | 22       | 6  | MAN | 7600-13000        |  | 1                | o | 50660303     |
| 160                  | 6,0    | 3,0    | 20       | 12 | MAN | 7600-13000        |  | 1                | o | 50660304     |

# HW RNK-Matador 5 Groefzaag HW

Product



Tekening

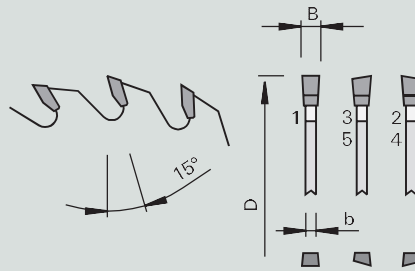

Machine



Toepassing



Uitvoering



3-0-1

HW TC03

F-WS-WS

Machine / gebruiksaanwijzing

- Weeke BHX serie
- CNC-bewerkingscentra en aggregaten
- Voor het braamvrij groeven zagen/frezen in massief hout, ruwe en beplakte plaatmaterialen op basis van hout

Uitvoering

- Tandvorm: vlak tand-wissel-tand-wissel tand "F-WS-WS"
- Snijmateriaal HW TC03

Voordelen

- Uitmuntende snijkwaliteit
- Extreem geluidsarm
- Langere standtijd door gebruik van zeer slijtvast snijmateriaal





Informatie - Tip

Producteigenschappen

Bestelinformatie

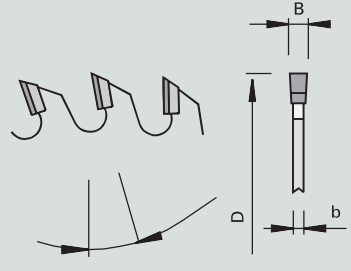
| Ø D [mm] | B [mm] | b [mm] | Ø d [mm] | Z  | Snijkwaliteit* NL** |                       | Spaanhoek [°]    |    | VE [St.] | V | Bestelnummer |
|----------|--------|--------|----------|----|---------------------|-----------------------|------------------|----|----------|---|--------------|
| 100      | 4,0    | 2,8    | 30       | 35 | ▲▲▲                 |                       | Weeke BHX        | 15 |          | 1 | 50806250     |
| 100      | 5,0    | 4,0    | 30       | 35 | ▲▲▲                 |                       | Weeke BHX        | 15 |          | 1 | 50806252     |
| 120      | 4,0    | 2,8    | 20       | 35 | ▲▲▲                 |                       | Weeke BHX        | 15 |          | 1 | 50806258     |
| 120      | 5,0    | 4,0    | 20       | 35 | ▲▲▲                 |                       | Weeke BHX        | 15 |          | 1 | 50806259     |
| 120      | 4,0    | 2,8    | 20       | 35 | ▲▲▲                 | 3/4,5/35              | SCM / Morbidelli | 15 |          | 1 | ⊗ 50806254   |
| 120      | 5,0    | 4,0    | 20       | 35 | ▲▲▲                 | 3/4,5/35              | SCM / Morbidelli | 15 |          | 1 | ⊗ 50806255   |
| 120      | 4,0    | 2,8    | 35       | 35 | ▲▲▲                 | 4/6,3/50              | Biesse           | 15 |          | 1 | ⊗ 50806256   |
| 120      | 5,0    | 4,0    | 35       | 35 | ▲▲▲                 | 4/6,3/50              | Biesse           | 15 |          | 1 | ⊗ 50806257   |
| 125      | 4,0    | 2,8    | 30       | 35 | ▲▲▲                 | 4/5,5/48R + 4/5,5/48L | Weeke BHX        | 15 |          | 1 | 50806251     |
| 125      | 5,0    | 4,0    | 30       | 35 | ▲▲▲                 | 4/5,5/48R + 4/5,5/48L | Weeke BHX        | 15 |          | 1 | 50806253     |





**DP** **RNK**  
Groefzaag diamant (DP)

|   |   |   |   |   |
|---|---|---|---|---|
| Product   | Tekening  | Machine   | Toepassing  | Uitvoering  |
|  |  |  |  | <br>4,0 mm<br><br>3-0-1<br><br>F |

|   |  |           |                  |
|---|--|-----------|------------------|
| Machine / gebruiksaanwijzing  | Uitvoering   | Voordelen | Informatie - Tip |
| <ul style="list-style-type: none"> <li>Tafelfreesmachines</li> <li>Voor het groeven zagen/frezen in; hout, kunststoffen, (beplakte) plaatmaterialen etc.</li> </ul> | <ul style="list-style-type: none"> <li>Tandvorm: vlaktand "F"</li> <li>Snijmateriaal DP</li> <li>Naslijpzone 4,0 mm</li> </ul> |           |                  |

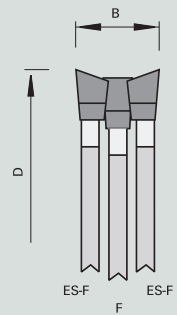
| Producteigenschappen |        |        |          |    |                |                       |               | Bestelinformatie |          |   |              |  |
|----------------------|--------|--------|----------|----|----------------|-----------------------|---------------|------------------|----------|---|--------------|--|
| Ø D [mm]             | B [mm] | b [mm] | Ø d [mm] | Z  | Snijkwaliteit* | NL**                  | Spaanhoek [°] | DKN [mm]         | VE [St.] | V | Bestelnummer |  |
| 100                  | 4,0    | 2,5    | 30       | 12 | ▲▲             | 4/5,5/48R + 4/5,5/48L | 8             |                  | 1        | s | 50750144     |  |
| 125                  | 4,0    | 2,5    | 30       | 12 | ▲▲             | 4/5,5/48R + 4/5,5/48L | 8             |                  | 1        | s | 50750145     |  |
| 160                  | 5,0    | 4,0    | 30       | 8  | ▲              |                       | 8             | 6x3              | 1        | s | 50750148     |  |
| 160                  | 8,0    | 7,0    | 30       | 8  | ▲              |                       | 8             | 6x3              | 1        | s | 50750149     |  |

**HW** **NK3VS**  
Groefcirkelzaagbladen HW - verstelbaar - eenzijdig spits-vlaktand + vlaktand + eenzijdig spits-vlaktand

|   |   |   |   |   |
|---|---|---|---|---|
| Product   | Tekening  | Machine   | Toepassing  | Uitvoering  |
|  |  |  |  | <br>3-0-1<br><br>HW<br>TC06<br><br>ES-F<br>F<br>ES-F |

|  |  |  |   |
|--|--|--|---|
| Machine / gebruiksaanwijzing   | Uitvoering   | Voordelen  | Informatie - Tip  |
| <ul style="list-style-type: none"> <li>Tafelcirkelzagen</li> <li>Afkortzagen</li> <li>Voor nauwkeurig groeven zagen in massief hout schulpen en afkorten en plaatmateriaal op basis van hout zoals spaanplaat, MDF etc.</li> </ul> | <ul style="list-style-type: none"> <li>3-delig, verstelbaar met tussenringen</li> <li>Extra spanningsleuven</li> <li>Tandvorm: voorritscirkelzaagblad eenzijdig spits-vlaktand "ES-F", hoofdcirkelzaagblad vlaktand "F"</li> <li>Tandbezetting: HW TC06</li> </ul> | <ul style="list-style-type: none"> <li>Nauwkeurig groeven zagen door speciale snijkantgeometrie</li> </ul> | <ul style="list-style-type: none"> <li>Verstelbaar in stappen van 0,1 mm</li> </ul> |

| Producteigenschappen |        |          |    |                |        |  |  | Bestelinformatie |          |   |              |  |
|----------------------|--------|----------|----|----------------|--------|--|--|------------------|----------|---|--------------|--|
| Ø D [mm]             | B [mm] | Ø d [mm] | Z  | Snijkwaliteit* | NL**   |  |  |                  | VE [St.] | V | Bestelnummer |  |
| 250                  | 5,0-13 | 30       | 30 | ▲▲▲            | Combi2 |  |  |                  | 1        |   | 50459024     |  |

# HW 1503 Groeffrezen Met HW-omkeermes

Product



Tekening

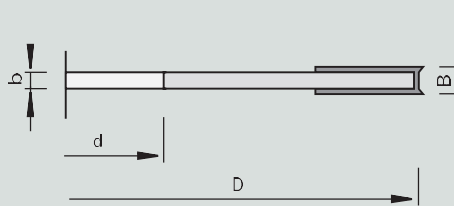

Machine



Toepassing



Uitvoering



Machine / gebruiksaanwijzing

- Tafelfreesmachines
- Voor het braamvrij groeffrezen in massief hout en plaatmateriaal op basis van hout

Uitvoering

- $n = 6.500 - 11.000$  (omw/min)

Voordelen

Informatie - Tip

- Toepassing: tegenlopende bewerkingen



Producteigenschappen

Bestelinformatie

| $\varnothing D$<br>[mm] | B<br>[mm] | b<br>[mm] | $\varnothing d$<br>[mm] | $\varnothing d_{max}$<br>[mm] | Z    |              | VE<br>[St.] | V         | Bestelnummer  |             |    |              |          |
|-------------------------|-----------|-----------|-------------------------|-------------------------------|------|--------------|-------------|-----------|---------------|-------------|----|--------------|----------|
| 125                     | 4,0       | 3,0       | 30                      | 40                            | 4 V4 |              | 1           |           | 50660318      |             |    |              |          |
| 125                     | 5,0       | 4,0       | 30                      | 40                            | 4 V4 |              | 1           | s         | 50660319      |             |    |              |          |
| Omkeermessen            |           |           |                         |                               |      | B<br>[mm]    | H<br>[mm]   | S<br>[mm] | Snijmateriaal | VE<br>[St.] | V  | Bestelnummer |          |
| Voorsnijder             |           |           |                         |                               |      |              | 14          | 14        | 1.2           | TCw30       | 10 |              | 50450182 |
| Omkeermessen            |           |           |                         |                               |      | Voor B = 4   | 18          | 18        | 1.95          | TCw20       | 10 |              | 50450220 |
| Toebehoren              |           |           | Afmeting<br>[mm]        |                               |      | Passend voor |             |           |               | VE<br>[St.] | V  | Bestelnummer |          |
| Verzonken kopschroeven  |           |           | M4x0,5x3,2 T9           |                               |      | 50660318     |             |           |               | 10          |    | 163925       |          |
| Speciaalmoeren          |           |           | M4x0,5x1,6              |                               |      | Voor alle    |             |           |               | 10          |    | 163704       |          |
| Speciaalmoeren          |           |           | M4x0,5x2,2              |                               |      | 50660318     |             |           |               | 10          |    | 163703       |          |
| Schroevendraaier        |           |           | T9                      |                               |      | Voor alle    |             |           |               | 1           |    | 164344       |          |

# HW 5561 Keermesen-Groeffrezen - Silverline

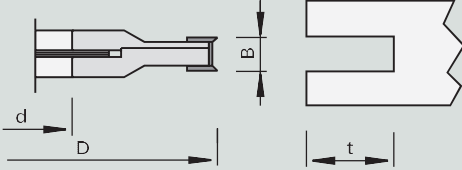
Verstelbaar met HW-omkeermes

|   |   |   |  |  |
|---|---|---|--|--|
| <b>Product</b><br> | <b>Tekening</b><br> | <b>Machine</b><br> | <b>Toepassing</b><br> | <b>Uitvoering</b><br><div style="border: 1px solid black; padding: 5px; margin-bottom: 5px;">STAHL</div> <div style="border: 1px solid black; padding: 5px; margin-bottom: 5px;">HW TCw15</div> <div style="border: 1px solid black; padding: 5px; margin-bottom: 5px;">HW TCw40</div> <div style="border: 1px solid black; padding: 5px;">MAN</div> |
|---|---|---|--|--|

|  |  |                      |   |
|--|--|----------------------|---|
| <b>Machine / gebruiksaanwijzing</b><br><ul style="list-style-type: none"> <li>Tafelfreesmachines</li> <li>Stationaire machines</li> <li>Formaatbewerkingsmachines</li> <li>Voor het braamvrij groeffrezen in massief hout en plaatmateriaal op basis van hout</li> </ul> | <b>Uitvoering</b><br><ul style="list-style-type: none"> <li>Body van staal</li> <li>Spaanbegrensd</li> <li>Bij voorkeur: handmatige aanvoer</li> </ul> | <b>Voordelen</b><br> | <b>Informatie - Tip</b><br><ul style="list-style-type: none"> <li>Toepassing: tegenlopende bewerkingen</li> <li>Snijbreedte 4 - 7,5 mm tweedelig</li> <li>Snijbreedte 4 - 15 mm driedelig</li> <li>Snijbreedte verstelbaar met tussenringen om de 0,1 mm</li> </ul> |
|--|--|----------------------|---|

| Producteigenschappen |         |          |           |      | Bestelinformatie |   |              |
|----------------------|---------|----------|-----------|------|------------------|---|--------------|
| Ø D [mm]             | B [mm]  | Ø d [mm] | Tmax [mm] | Z    | VE [St.]         | V | Bestelnummer |
| 160                  | 4,0-7,5 | 30       | 35        | 8 V8 |                  | 1 | o 68370033   |
| 160                  | 4,0-7,5 | 40       | 35        | 8 V8 |                  | 1 | o 68370034   |
| 200                  | 4,0-7,5 | 30       | 55        | 8 V8 |                  | 1 | o 68370053   |
| 200                  | 4,0-7,5 | 40       | 55        | 8 V8 |                  | 1 | o 68370054   |
| 200                  | 4,0-7,5 | 50       | 55        | 8 V8 |                  | 1 | o 68370055   |

| Tussenfrezen producteigenschappen |        |          |           |   | Bestelinformatie |   |              |
|-----------------------------------|--------|----------|-----------|---|------------------|---|--------------|
| Ø D [mm]                          | B [mm] | Ø d [mm] | Tmax [mm] | Z | VE [St.]         | V | Bestelnummer |
| 160                               | 7,6    | 30       | 35        | 2 | 1                | o | 68370083     |
| 160                               | 7,6    | 40       | 35        | 2 | 1                | o | 68370084     |
| 200                               | 7,6    | 30       | 55        | 2 | 1                | o | 68370103     |
| 200                               | 7,6    | 40       | 55        | 2 | 1                | o | 68370104     |
| 200                               | 7,6    | 50       | 55        | 2 | 1                | o | 68370105     |

| Omkeermessen | B [mm] | H [mm] | S [mm] | Snijmateriaal | VE [St.] | V | Bestelnummer |
|--------------|--------|--------|--------|---------------|----------|---|--------------|
| Omkeermessen | 18     | 18     | 1.95   | TCw20         | 10       |   | 50450220     |
| Voorsnijder  | 14     | 14     | 2.0    | TCw30         | 10       |   | 50820014     |

# HW 5561 Keermesen-Groeffrezen - Silverline

Verstelbaar met HW-omkeermes

Product



Tekening

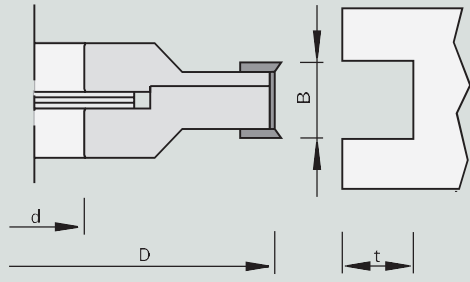

Machine



Toepassing



Uitvoering

- STAHL
- HW TCw05
- HW TCw40
- MAN

|   |  |   |  |
|---|--|---|--|
| <p>Machine / gebruiksaanwijzing</p> <ul style="list-style-type: none"> <li>• Tafelfreesmachines</li> <li>• Stationaire machines</li> <li>• Formaatbewerkingsmachines</li> <li>• Voor het braamvrij groeffrezen in massief hout en plaatmateriaal op basis van hout</li> </ul> | <p>Uitvoering</p> <ul style="list-style-type: none"> <li>• Body van staal</li> </ul> | <p>Voordelen</p> <ul style="list-style-type: none"> <li>• Optimale snijkwaliteit</li> </ul> | <p>Informatie - Tip</p> <ul style="list-style-type: none"> <li>• Toepassing: tegenlopende bewerkingen</li> <li>• Snijbreedte verstelbaar met tussenringen om de 0,1 mm</li> <li>• Vergroting groefbreedte door gebruik van tussenfrezen</li> </ul> |
|---|--|---|--|

| Producteigenschappen |           |          |           |      | Bestelinformatie |   |              |
|----------------------|-----------|----------|-----------|------|------------------|---|--------------|
| Ø D [mm]             | B [mm]    | Ø d [mm] | Tmax [mm] | Z    | VE [St.]         | V | Bestelnummer |
| 160                  | 8,0-15,5  | 30       | 35        | 4 V4 | 1                | o | 68380023     |
| 160                  | 8,0-15,5  | 40       | 35        | 4 V4 | 1                | o | 68380024     |
| 160                  | 12,5-24,0 | 30       | 32        | 4 V4 | 1                | o | 68390023     |
| 160                  | 12,5-24,0 | 40       | 32        | 4 V4 | 1                | o | 68390024     |
| 160                  | 15,0-30,0 | 30       | 32        | 4 V4 | 1                | o | 68400063     |
| 160                  | 15,0-30,0 | 40       | 32        | 4 V4 | 1                | o | 68400064     |
| 200                  | 8,0-15,5  | 30       | 50        | 4 V4 | 1                | o | 68380033     |
| 200                  | 8,0-15,5  | 40       | 50        | 4 V4 | 1                | o | 68380034     |
| 200                  | 8,0-15,5  | 50       | 50        | 4 V4 | 1                | o | 68380035     |
| 200                  | 12,5-24,0 | 30       | 45        | 4 V4 | 1                | o | 68390033     |
| 200                  | 12,5-24,0 | 40       | 45        | 4 V4 | 1                | o | 68390034     |
| 200                  | 12,5-24,0 | 50       | 45        | 4 V4 | 1                | o | 68390035     |
| 200                  | 15,0-30,0 | 30       | 50        | 4 V4 | 1                | o | 68400033     |
| 200                  | 15,0-30,0 | 40       | 50        | 4 V4 | 1                | o | 68400034     |
| 200                  | 15,0-30,0 | 50       | 50        | 4 V4 | 1                | o | 68400035     |
| 250                  | 8,0-15,0  | 30       | 52        | 8 V8 | 1                | o | 68380043     |
| 250                  | 8,0-15,0  | 40       | 52        | 8 V8 | 1                | o | 68380044     |
| 250                  | 8,0-15,0  | 50       | 52        | 8 V8 | 1                | o | 68380045     |

| Tussenfrezen producteigenschappen |        |          |           |   | Bestelinformatie |   |              |
|-----------------------------------|--------|----------|-----------|---|------------------|---|--------------|
| Ø D [mm]                          | B [mm] | Ø d [mm] | Tmax [mm] | Z | VE [St.]         | V | Bestelnummer |
| 200                               | 12,0   | 30       | 45        | 2 | 1                | o | 68390073     |
| 200                               | 12,0   | 40       | 45        | 2 | 1                | o | 68390074     |
| 200                               | 12,0   | 50       | 45        | 2 | 1                | o | 68390075     |
| 200                               | 15,0   | 30       | 45        | 2 | 1                | o | 68380083     |
| 200                               | 15,0   | 40       | 45        | 2 | 1                | o | 68380084     |
| 200                               | 15,0   | 50       | 45        | 2 | 1                | o | 68380085     |

| Omkeermessen | B [mm] | H [mm] | S [mm] | Snijmateriaal | VE [St.] | V | Bestelnummer |
|--------------|--------|--------|--------|---------------|----------|---|--------------|
| Omkeermessen | 12     | 12     | 1.5    | TC05          | 10       |   | 50820012     |
| Omkeermessen | 15     | 12     | 1.5    | TC05          | 10       |   | 50820015     |
| Voorsnijder  | 14     | 14     | 2.0    | TCw30         | 10       |   | 50820014     |
| Omkeermessen | 7,5    | 12     | 1.5    | TC05          | 10       |   | 50820007     |

# HW 1586 Groef- en sponningfrezen- Silverline

Met tweezijdig scherende snede

Product



Tekening

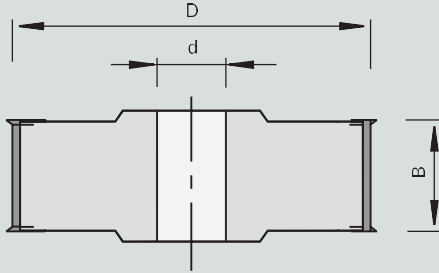

Machine



Toepassing



Uitvoering

STAHL

HW TC05

MAN

|  |   |   |  |
|--|---|---|--|
| <p>Machine / gebruiksaanwijzing</p> <ul style="list-style-type: none"> <li>• Tafelfreesmachines</li> <li>• Voor het braamvrij voegfrezen en groeffrezen in massief hout en plaatmateriaal op basis van hout</li> <li>• Gecoat, niet-gecoat en verlijmd volhout en sterk slijtende houtsoorten</li> </ul> | <p>Uitvoering</p> <ul style="list-style-type: none"> <li>• Met afwisselende ashoek voor trekkende snede</li> <li>• Snijmateriaal: HW TC05</li> <li>• Body van staal</li> <li>• 4x ruimers</li> <li>• voorsnijders: 2 boven en 2 onder</li> <li>• Trekkende snede</li> </ul> | <p>Voordelen</p> <ul style="list-style-type: none"> <li>• Optimale snijkwaliteit</li> </ul> | <p>Informatie - Tip</p> <ul style="list-style-type: none"> <li>• Toepassing: tegenlopende bewerkingen</li> </ul> |
|--|---|---|--|

| Producteigenschappen |        |          |      |  |                   | Bestelinformatie |          |                |
|----------------------|--------|----------|------|--|-------------------|------------------|----------|----------------|
| Ø D [mm]             | B [mm] | Ø d [mm] | Z    |  | nmin-nmax [min-1] |                  | VE [St.] | V Bestelnummer |
| 125                  | 30     | 30       | 4 V4 |  | 9000              |                  | 1        | o 68010013     |
| 125                  | 30     | 40       | 4 V4 |  | 9000              |                  | 1        | o 68010014     |
| 125                  | 30     | 50       | 4 V4 |  | 9000              |                  | 1        | o 68010015     |
| 125                  | 50     | 30       | 4 V4 |  | 9000              |                  | 1        | o 68010023     |
| 125                  | 50     | 40       | 4 V4 |  | 9000              |                  | 1        | o 68010024     |
| 125                  | 50     | 50       | 4 V4 |  | 9000              |                  | 1        | o 68010025     |
| 140                  | 50     | 30       | 4 V4 |  | 9000              |                  | 1        | o 68010043     |
| 140                  | 50     | 40       | 4 V4 |  | 9000              |                  | 1        | o 68010044     |
| 140                  | 50     | 50       | 4 V4 |  | 9000              |                  | 1        | o 68010045     |

|              | B [mm] | H [mm] | S [mm] | Snijmateriaal | VE [St.] | V Bestelnummer |
|--------------|--------|--------|--------|---------------|----------|----------------|
| Voorsnijder  | 14     | 14     | 2.0    | TCw30         | 10       | 50820014       |
| Omkeermessen | 50     | 12     | 1.5    | TC05          | 10       | 50820050       |
| Omkeermessen | 30     | 12     | 1.5    | TC05          | 10       | 50820030       |



DP

# 3584 Voegenfrees

MAN

Product

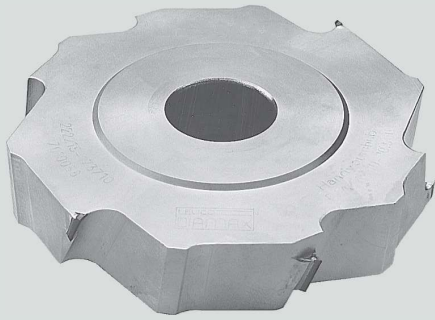

Tekening

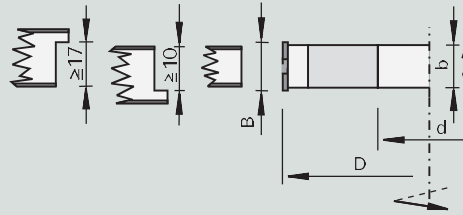

Machine



Toepassing



Uitvoering



Machine / gebruiksaanwijzing

- Tafelfreesmachines
- Voor het braamvrij maken van veren en groeven in met melaminehars en papier bekleed, HPL-, folie bekleed en gefineerd plaatmateriaal op basis van hout

Uitvoering

- Spiraalvormig snijkantpatroon
- Naslijpzone 1,5 mm

Voordelen

- Optimale verlijming van kanten

Informatie - Tip

- Draairichting volgens DIN-EN 50144

Producteigenschappen

Bestelinformatie

| Ø D [mm] | B [mm] | b [mm] | Ø d [mm] | Z   | DKN [mm] | nmin-nmax [min-1] | VE [St.] | V | Bestelnr. [L] | V | Bestelnr. [R] |
|----------|--------|--------|----------|-----|----------|-------------------|----------|---|---------------|---|---------------|
| 125      | 25     | 26     | 30       | 2+2 | 8x3      | 6 100-10500       | 1        |   | 50811729      |   | 50811729      |
| 125      | 43     | 44     | 30       | 2+2 | 8x3      | 6 100-10500       | 1        | s | 50811300      | s | 50811300      |

## DP 3585 Voegenfrees DP airFace

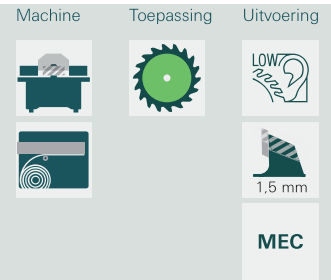
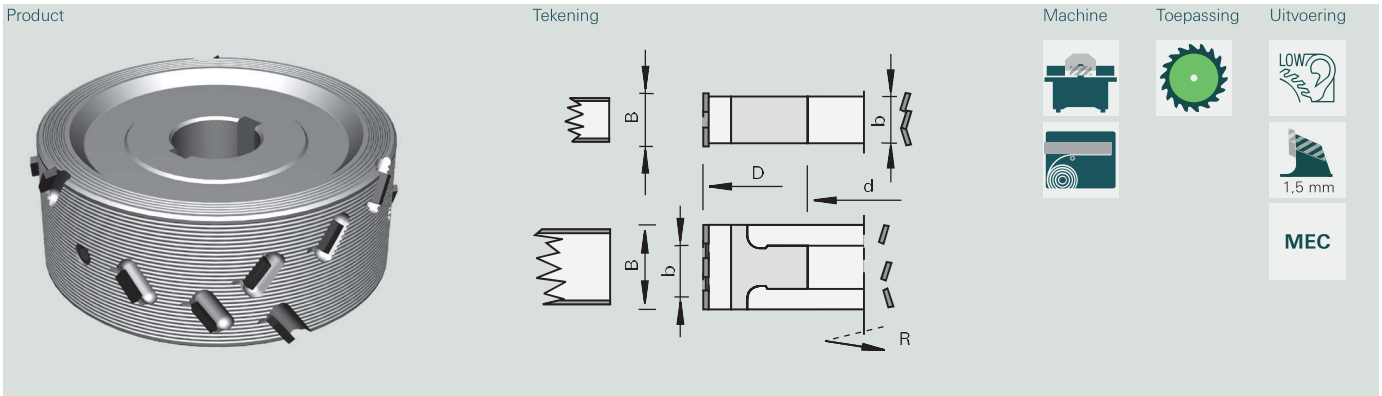

### Machine / gebruiksaanwijzing

- Doorlooppinstallaties
- Kantenaanlijmmachines
- Voor het zeer geluidsarm en braamvrij voegen van massiefhout en plaatmaterialen met of zonder coating. Dit met een bijzondere focus op onbalans, geluidsreducering en spaanafvoer

### Uitvoering

- Staal basisonderdeel met airFace-oppervlak
- Geïntegreerde stelschroeven
- Versterkte DP-snijden
- Kleinere spaanruimte
- Ashoek 35°
- Naslijpzone 1,5 mm

### Voordelen

- Geluidsreductie met nog eens -1 dB(A) door airFace-design en verminderd spaanruimtevolume in vergelijking met de LowNoise-versie
- Goede standtijd prestatie en snijkwaliteit door de grote ashoek
- Verwerking van 8 mm platen zonder verstellen mogelijk

### Informatie - Tip

- Draairichting volgens DIN-EN 50144

### Producteigenschappen

### Bestelinformatie

| Ø D [mm] | B [mm] | b [mm] | Ø d [mm] | Z   | DKN [mm] | nmax [min-1] |                                     |              | VE [St.] | V | Bestelnr. [L] | V | Bestelnr. [R]              |
|----------|--------|--------|----------|-----|----------|--------------|-------------------------------------|--------------|----------|---|---------------|---|----------------------------|
| 60       | 64,5   | 62     | 25       | 2+2 | 8x3,3    | 31000        | Felder/Format 4                     |              | 1        |   | 58186382      |   | 58186381 <span>NEUW</span> |
| 85       | 43,2   | 50     | 30       | 3+3 | 8x3,3    | 22000        | Ott                                 | asymmetrisch | 1        |   | 58186408      |   | 58186409 <span>NEUW</span> |
| 100      | 43,2   | 25     | 30       | 2+2 | 8x3,3    | 19000        | HOLZ-HER- tot 2008, SCM-Stefani     |              | 1        |   | 58186385      |   | 58186386 <span>NEUW</span> |
| 100      | 43,2   | 40,6   | 30       | 3+3 | 8x3,3    | 19000        | Brandt                              | asymmetrisch | 1        |   | 58186373      |   | 58186374 <span>NEUW</span> |
| 100      | 43,2   | 60,6   | 30       | 3+3 | 8x3,3    | 19000        | SCM-Stefani                         | asymmetrisch | 1        |   | 58186414      |   | 58186415 <span>NEUW</span> |
| 100      | 43,2   | 61     | 30       | 2+2 | 8x3,3    | 19000        | EBM / Hebrock                       | asymmetrisch | 1        |   | 58186378      |   | 58186377 <span>NEUW</span> |
| 100      | 64,5   | 40,6   | 30       | 3+3 | 8x3,3    | 19000        | Brandt                              | asymmetrisch | 1        |   | 58186371      |   | 58186372 <span>NEUW</span> |
| 100      | 64,5   | 25     | 30       | 2+2 | 8x3,3    | 19000        | HOLZ-HER tot 2008, SCM-Stefani, EBM |              | 1        |   | 58186387      |   | 58186388 <span>NEUW</span> |
| 125      | 29     | 34     | 30       | 3+3 | 8x3,3    | 15000        | Homag                               |              | 1        |   | 58186401      |   | 58186401 <span>NEUW</span> |
| 125      | 43,2   | 40     | 30       | 3+3 | 8x3,3    | 15000        | Homag                               |              | 1        |   | 58186399      |   | 58186399 <span>NEUW</span> |
| 125      | 64     | 40     | 30       | 3+3 | 8x3,3    | 15000        | Homag                               |              | 1        |   | 58186400      |   | 58186400 <span>NEUW</span> |

## DP 3585-2 voegenfrees DP - HOLZ-HER - AirStream-systeem

Product



Tekening

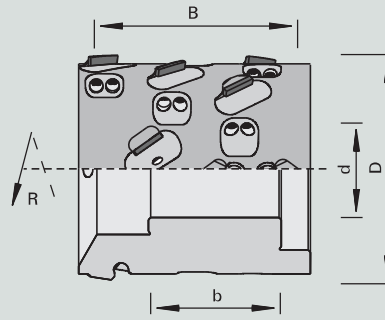

Machine



Toepassing



Uitvoering



max.  
**18.000**  
U/min



**MEC**

Machine / gebruiksaanwijzing

- Doorloopinstallaties HOLZ-HER aggregaat 1801/1802/1804
- Voor het bijzonder geluidsarm braamvrij maken van voegen in met melaminehars en papier beklede, HPL-, foliebeklede en gefineerd plaatmateriaal op basis van hout

Uitvoering

- Met gepatenteerd AirStream-systeem
- symmetrische en asymmetrische uitvoering 35°
- Ashoek naslijpzone 1,5 mm

Voordelen

- Optimale verlijming van de kanten
- Zeer geluidarm en zuinig door AirStream-systeem
- Duidelijk hogere spaanbepalingsgraad door AirStream-systeem
- Hogere standtijd door reduceren van de dubbele verspaning
- Minder vervuiling van de machine met spanen
- Goede snijkwaliteit door de grote ashoek

Informatie - Tip

- compatibel met Pro Lock-spanning bij oudere aggregaten
- Draairichting volgens DIN-EN 50144

Producteigenschappen

Bestelinformatie

| Ø D [mm] | B [mm] | b [mm] | Ø d [mm] | Z   | DKN [mm] | nmax [min-1] |                          | VE [St.] | V | Bestelnr. [L] | V | Bestelnr. [R] |
|----------|--------|--------|----------|-----|----------|--------------|--------------------------|----------|---|---------------|---|---------------|
| 70       | 48     | 41     | 30       | 2+2 | 8x3,3    | 18000        | HOLZ-HER aggr. 1801/1802 | 1        |   | 50811780      |   | 50811781      |
| 70       | 64     | 41     | 30       | 2+2 | 8x3,3    | 18000        | HOLZ-HER aggr. 1801/1802 | 1        |   | 50811782      |   | 50811783      |
| 100      | 63     | 40     | 30       | 3+3 | 8x3,3    | 18500        | HOLZ-HER aggr. 1804      | 1        |   | 50811784      |   | 50811785      |

## DP 3588-2 Strijkfrezen airFace

Met verwisselbare DP-messen

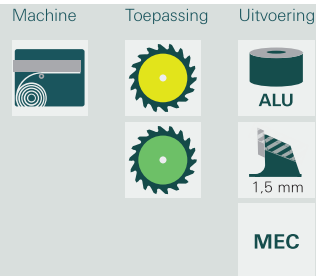
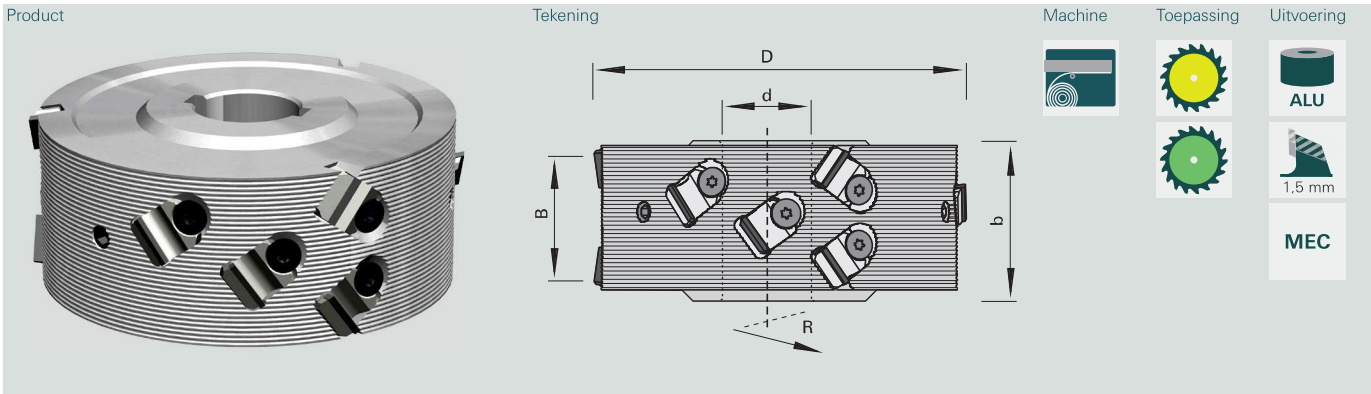

### Machine / gebruiksaanwijzing

- Kantenaanlijmmachines
- Voor het bijzonder geluidsarm bewerken van massief hout en plaatmaterialen met of zonder toplaag. Dit met een bijzondere focus op onbalans, geluidsreductie en spaanafvoer

### Uitvoering

- Body van aluminium met airFace-oppervlak
- Met verwisselbare DP-snijmesjes met geïntegreerde roestvrijstalen spaanruimte
- Ashoek 35°
- Naslijpzone 1,5 mm

### Voordelen

- Geluidsreductie tot max. -3 dB(A) boven op het airFace-design
- Minder vermogensopname door lichte uitvoering met aluminium body.
- Minder asbelasting door verminderde onbalans
- Verwisselbare DP-messen incl. slijtvaste, verwisselbare spaanruimte
- Zeer goede snijkwaliteit door de grote ashoek
- Corrosiebescherming op het hele gereedschap door roestvrijstalen messen

### Informatie - Tip

- LET OP! Bij het verwisselen van de messen de gebruiksaanwijzing in acht nemen
- DP-messen verpakkingseenheid 4 stuks
- Steekinzetstuk verpakkingseenheid 2 stuks
- Draairichting volgens DIN-EN 50144

## Strijkrees airFace Ø d=70/35°

| Producteigenschappen |        |        |          |     |          |              |     | Bestelinformatie    |          |   |               |   |  |
|----------------------|--------|--------|----------|-----|----------|--------------|-----|---------------------|----------|---|---------------|---|--|
| Ø D [mm]             | B [mm] | b [mm] | Ø d [mm] | Z   | DKN [mm] |              |     | Aantal messen [St.] | VE [St.] | V | Bestelnr. [L] | V | Bestelnr. [R]                                |
| 70                   | 43     | 61     | 25       | 2+2 | 8x3,3    | asymmetrisch | EBM | 8                   | 1        |   | 50186037      |   | 50186038 <span style="color:red">NEUW</span> |
| Toebehoren           |        |        |          |     |          |              |     | Afmeting [mm]       |          |   | VE [St.]      | V | Bestelnummer                                 |
| DP-messen            |        |        |          |     |          |              |     | Ø D=70 / 35°        |          |   | 4             |   | 186076                                       |

## Strijkrees airFace Ø d=80/35°

| Producteigenschappen |        |        |          |     |          |             |             | Bestelinformatie    |          |   |               |   |  |
|----------------------|--------|--------|----------|-----|----------|-------------|-------------|---------------------|----------|---|---------------|---|--|
| Ø D [mm]             | B [mm] | b [mm] | Ø d [mm] | Z   | DKN [mm] |             |             | Aantal messen [St.] | VE [St.] | V | Bestelnr. [L] | V | Bestelnr. [R]                                |
| 80                   | 43     | 53     | 30       | 2+2 | 8x3,3    | symmetrisch | Biesse Jade | 8                   | 1        |   | 50186031      |   | 50186031 <span style="color:red">NEUW</span> |
| Toebehoren           |        |        |          |     |          |             |             | Afmeting [mm]       |          |   | VE [St.]      | V | Bestelnummer                                 |
| DP-messen            |        |        |          |     |          |             |             | Ø D=80 / 35°        |          |   | 4             |   | 186077                                       |

## Strijkrees airFace Ø d=85/35°

| Producteigenschappen |        |        |          |     |          |              |     | Bestelinformatie    |          |   |               |   |  |
|----------------------|--------|--------|----------|-----|----------|--------------|-----|---------------------|----------|---|---------------|---|--|
| Ø D [mm]             | B [mm] | b [mm] | Ø d [mm] | Z   | DKN [mm] |              |     | Aantal messen [St.] | VE [St.] | V | Bestelnr. [L] | V | Bestelnr. [R]                                |
| 85                   | 48     | 50     | 30       | 3+3 | 8x3,3    | asymmetrisch | Ott | 15                  | 1        |   | 50186058      |   | 50186057 <span style="color:red">NEUW</span> |
| Toebehoren           |        |        |          |     |          |              |     | Afmeting [mm]       |          |   | VE [St.]      | V | Bestelnummer                                 |
| DP-messen            |        |        |          |     |          |              |     | Ø D=85 / 35°        |          |   | 4             |   | 186078                                       |

## Strijkfrees airFace Ø d=100/35

| Producteigenschappen |        |               |          |     |          |              |                       | Bestelinformatie    |  |          |          |               |              |               |  |
|----------------------|--------|---------------|----------|-----|----------|--------------|-----------------------|---------------------|--|----------|----------|---------------|--------------|---------------|--|
| Ø D [mm]             | B [mm] | b [mm]        | Ø d [mm] | Z   | DKN [mm] |              |                       | Aantal messen [St.] |  | VE [St.] | V        | Bestelnr. [L] | V            | Bestelnr. [R] |  |
| 100                  | 43     | 40.6          | 25       | 2+2 | 8x3,3    | asymmetrisch | Brandt 1110F, 1120 FC | 8                   |  | 1        |          | 50186071      |              | 50186072      |  |
| 100                  | 43     | 40.6          | 30       | 3+3 | 8x3,3    | asymmetrisch | Brandt                | 12                  |  | 1        |          | 50186065      |              | 50186066      |  |
| 100                  | 64     | 40.6          | 30       | 3+3 | 8x3,3    | asymmetrisch | Brandt, SCM           | 18                  |  | 1        |          | 50186073      |              | 50186074      |  |
| 100                  | 43     | 60.6          | 30       | 3+3 | 8x3,3    | asymmetrisch | SCM                   | 12                  |  | 1        |          | 50186063      |              | 50186064      |  |
| 100                  | 64     | 60.6          | 30       | 3+3 | 8x3,3    | asymmetrisch | SCM                   | 18                  |  | 1        |          | 50186062      |              | 50186061      |  |
| Toebehoren           |        | Afmeting      |          |     |          |              |                       |                     |  |          | VE [St.] | V             | Bestelnummer |               |  |
| DP-messen            |        | Ø D=100 / 35° |          |     |          |              |                       |                     |  |          | 4        |               | 185250       |               |  |

## Strijkfrees airFace Ø d=125/35°



| Producteigenschappen |        |               |          |     |          |              |            | Bestelinformatie    |  |          |          |               |              |               |  |
|----------------------|--------|---------------|----------|-----|----------|--------------|------------|---------------------|--|----------|----------|---------------|--------------|---------------|--|
| Ø D [mm]             | B [mm] | b [mm]        | Ø d [mm] | Z   | DKN [mm] |              |            | Aantal messen [St.] |  | VE [St.] | V        | Bestelnr. [L] | V            | Bestelnr. [R] |  |
| 125                  | 43     | 40            | 30       | 3+3 | 8x3,3    | symmetrisch  | Homag      | 12                  |  | 1        |          | 50186047      |              | 50186047      |  |
| 125                  | 64     | 40            | 30       | 3+3 | 8x3,3    | symmetrisch  | Homag      | 18                  |  | 1        |          | 50186048      |              | 50186048      |  |
| 125                  | 32,5   | 54            | 30       | 3+3 | 8x3,3    | asymmetrisch | Homag      | 9                   |  | 1        |          | 58186307      |              | 58186306      |  |
| 125                  | 43,2   | 54            | 30       | 3+3 | 8x3,3    | asymmetrisch | Homag      | 12                  |  | 1        |          | 50185971      |              | 50185970      |  |
| 125                  | 64,4   | 54            | 30       | 3+3 | 8x3,3    | asymmetrisch | Homag      | 18                  |  | 1        |          | 50185973      |              | 50185972      |  |
| 125                  | 43,2   | 72            | 30       | 3+3 | 8x3,3    | asymmetrisch | IMA 08.378 | 12                  |  | 1        |          | 50186051      |              | 50186052      |  |
| 125                  | 64,4   | 72            | 30       | 3+3 | 8x3,3    | asymmetrisch | IMA 08.378 | 18                  |  | 1        |          | 50186049      |              | 50186050      |  |
| Toebehoren           |        | Afmeting      |          |     |          |              |            |                     |  |          | VE [St.] | V             | Bestelnummer |               |  |
| DP-messen            |        | Ø D=125 / 35° |          |     |          |              |            |                     |  |          | 4        |               | 185974       |               |  |

## Strijkfrees airFace Ø d=125/43°

| Producteigenschappen                    |        |               |          |     |          |              |            | Bestelinformatie    |  |          |          |               |              |               |  |
|---|--------|---------------|----------|-----|----------|--------------|------------|---------------------|--|----------|----------|---------------|--------------|---------------|--|
| Ø D [mm]                                | B [mm] | b [mm]        | Ø d [mm] | Z   | DKN [mm] |              |            | Aantal messen [St.] |  | VE [St.] | V        | Bestelnr. [L] | V            | Bestelnr. [R] |  |
| 125                                     | 63     | 57            | 30       | 3+3 | 8x3,3    | asymmetrisch | IMA 08.379 | 21                  |  | 1        |          | 50186055      |              | 50186056      |  |
| Toebehoren                              |        | Afmeting      |          |     |          |              |            |                     |  |          | VE [St.] | V             | Bestelnummer |               |  |
| DP-messen                               |        | Ø D=125 / 43° |          |     |          |              |            |                     |  |          | 4        |               | 186075       |               |  |
| Reserveonderdelen/toebehoren            |        | Afmeting [mm] |          |     |          |              |            |                     |  |          | VE [St.] | V             | Bestelnummer |               |  |
| Momentschroevendraaier zonder inzetstuk |        | 5,0 Nm        |          |     |          |              |            |                     |  |          | 1        |               | 185292       |               |  |
| Steekinzetstuk torx                     |        | T20           |          |     |          |              |            |                     |  |          | 2        |               | 185293       |               |  |

# HW 1580 Zwenkfrezen

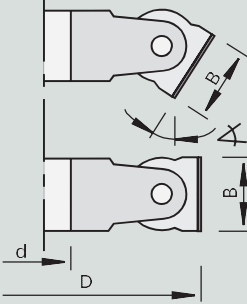
Met HW-omkeermes

|  |   |   |    |      |     |  |
|--|---|---|----|------|-----|--|
| <p>Product</p>  | <p>Tekening</p>  | <p>Machine</p>  <p>Toepassing</p>  <p>Uitvoering</p> <table border="1"> <tr> <td>HW</td> <td>TC05</td> </tr> <tr> <td>MAN</td> <td></td> </tr> </table> | HW | TC05 | MAN |  |
| HW   | TC05  |   |    |      |     |  |
| MAN  |   |   |    |      |     |  |

|  |   |  |  |
|--|---|--|--|
| <p>Machine / gebruiksaanwijzing</p> <ul style="list-style-type: none"> <li>Tafelfreesmachines</li> <li>Voor het afkanten, voegfrezen en sponningfrezen in massief hout en gefineerd en met kunststof bekleed plaatmateriaal op basis van hout met instelbare fase</li> </ul> | <p>Uitvoering</p> <ul style="list-style-type: none"> <li>Snijkanten asparallel</li> <li>Tandbezetting: HW TC05</li> </ul> | <p>Voordelen</p> <ul style="list-style-type: none"> <li>Vereenvoudigde instelling door getande ring</li> </ul> | <p>Informatie - Tip</p> <ul style="list-style-type: none"> <li>Toepassing tegenlopend</li> <li>Fase tot 90 graden zwenkbaar</li> <li>Fase per graad verstelbaar</li> </ul> |
|--|---|--|--|

| Producteigenschappen     |        |                  |   |        |                   | Bestelinformatie |               |              |              |              |
|--------------------------|--------|------------------|---|--------|-------------------|------------------|---------------|--------------|--------------|--------------|
| Ø D [mm]                 | B [mm] | Ø d [mm]         | Z |        | nmin-nmax [min-1] | VE [St.]         | V             | Bestelnummer |              |              |
| 167                      | 50     | 30               | 2 |        | 4600-7800         | 1                |               | 50663009     |              |              |
| Omkeermessen             |        |                  |   | B [mm] | H [mm]            | S [mm]           | Snijmateriaal | VE [St.]     | V            | Bestelnummer |
|                          |        |                  |   | 50     | 12                | 1.5              | TC05          | 10           |              | 50820050     |
| Toebehoren               |        | Afmeting [mm]    |   |        |                   |                  | VE [St.]      | V            | Bestelnummer |              |
| Draadstift               |        | M6x16 SW3        |   |        |                   |                  | 10            |              | 001617       |              |
| Schroevendraaier         |        | SW3x100          |   |        |                   |                  | 1             |              | 166090       |              |
| Haakse schroevendraaiers |        | SW6 DIN ISO 2936 |   |        |                   |                  | 1             |              | 009675       |              |
| Drukstuk                 |        | B=50             |   |        |                   |                  | 2             |              | 50930124     |              |

## DP 3565 Kanten-afrodfrees

Product

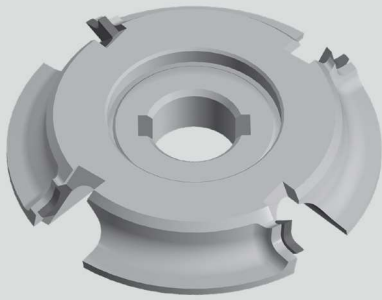

Tekening

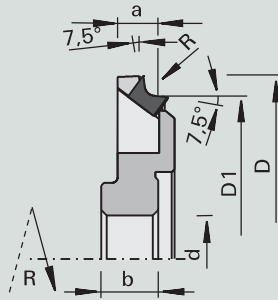

Machine



Toepassing



Uitvoering



Machine / gebruiksaanwijzing

- Kantenaanlijmmachines Ott
- Voor het afronden van kantfineer bij massief hout en fineer- en kunststofranden

Uitvoering

- Gepolijst spaanvlak
- Fijnstbewerkte vrijloopvlak
- Met ashoek
- n max = 24.000 min-1

Voordelen

- Optimale snedekwaliteit

Informatie - Tip

- Basismaten a en D1 constant
- Draairichting volgens DIN-EN 50144

Producteigenschappen

Bestelinformatie

| R [mm] | Ø D [mm] | Ø D1 [mm] | a [mm] | b [mm] | Ø d [mm] | Z | DKN [mm] | VE [St.] | V | Bestelnr. [L] | V | Bestelnr. [R] |
|--------|----------|-----------|--------|--------|----------|---|----------|----------|---|---------------|---|---------------|
| 2,0    | 69       | 61        | 9.72   | 10.5   | 16       | 4 | 5x2,3    | 1        |   | 50811738      |   | 50811737      |

## DP 3565-1 Kanten-afrodfrees

Product

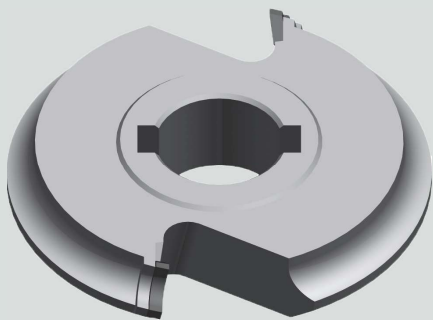

Tekening

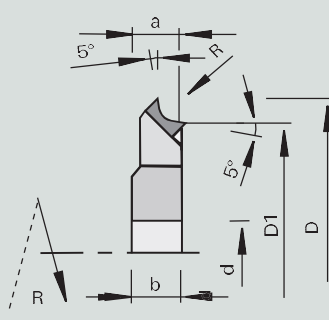

Machine



Toepassing



Uitvoering



Machine / gebruiksaanwijzing

- Kantenaanlijmmachines HOLZ-HER
- Voor het afronden van kantfineer bij massief hout en fineer- en kunststofranden

Uitvoering

- Met ashoek
- n max = 24.000 min-1

Voordelen

Informatie - Tip

- Basismaten a en D1 constant
- Draairichting volgens DIN-EN 50144

Producteigenschappen

Bestelinformatie

| R [mm] | Ø D [mm] | Ø D1 [mm] | a [mm] | b [mm] | Ø d [mm] | Z | DKN [mm] | VE [St.] | V | Bestelnr. [L] | V | Bestelnr. [R] |
|--------|----------|-----------|--------|--------|----------|---|----------|----------|---|---------------|---|---------------|
| 2,0    | 57       | 50        | 8.5    | 12.5   | 16       | 2 | 5x2,3    | 1        |   | 50811740      |   | 50811739      |

## DP 3565-2 Kanten-afrodfrees CM

Product

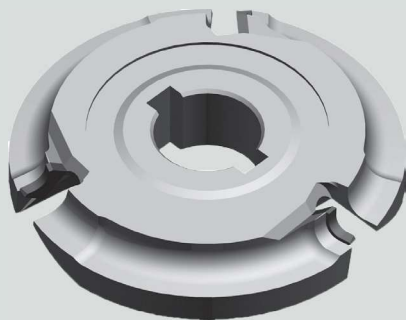

Tekening

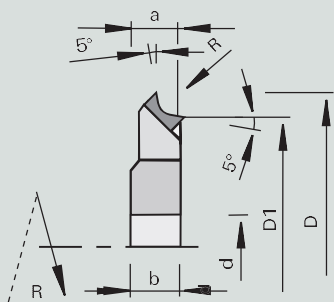

Machine



Toepassing



Uitvoering



Machine / gebruiksaanwijzing

- Kantenaanlijmmachines HOLZ-HER aggregaat 1832
- Voor het afronden van kantfinez bij massief hout en fineer- en kunststofranden

Uitvoering

- Met ashoek
- Gepolijst spaanvlak en zeer fijn bewerkt vrijloopvlak
- n max = 24.000 min-1

Voordelen

- Geoptimaliseerde spaanafvoer
- Geen vervuiling van de machine met spanen
- Geen functiestoringen door spanen
- Vermindering van het afzuigvermogen
- Geluidsarm

Informatie - Tip

- Basismaten a en D1 constant
- Draairichting volgens DIN-EN 50144

Producteigenschappen

Bestelinformatie

| R [mm] | Ø D [mm] | Ø D1 [mm] | a [mm] | b [mm] | Ø d [mm] | Z | DKN [mm] |  | VE [St.] | V | Bestelnummer         |
|--------|----------|-----------|--------|--------|----------|---|----------|--|----------|---|----------------------|
| 2,0    | 58,7     | 50        | 8,5    | 12     | 16       | 3 | 5x2,3    |  | 1        |   | 50811743             |
| 3,0    | 58,7     | 50        | 8,5    | 12     | 16       | 3 | 5x2,3    |  | 1        |   | 50182686 <b>NEUW</b> |



## HW 5540 Bossingfreesen - Silverline

Product



Tekening

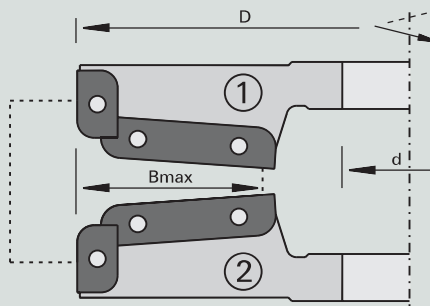

Machine



Toepassing



Uitvoering



Machine / gebruiksaanwijzing

- Tafelfreesmachine
- Voor het profileren van panelen in massief hout en houtbevattende plaatmaterialen

Uitvoering

- Body van staal
- Snijkanten asparallel
- Snijmateriaal: HW TC05

Voordelen

- Tot 12 verschillende profielen in dezelfde kop mogelijk
- Door hoogterstelling nog meer varianten mogelijk

Informatie - Tip

- Leveringsomvang: 1 vlakfreeskop met gemonteerde messen voor profiel B (62556021, 62556022)
- Alternatieve profielen niet inbegrepen

Producteigenschappen

Bestelinformatie

| Ø D [mm] | Bmax [mm] | Ø d [mm] | Z   | Freesnr. | nmin-nmax [min-1] | L |  | VE [St.] | V | Bestelnummer |
|----------|-----------|----------|-----|----------|-------------------|---|--|----------|---|--------------|
| 200      | 60        | 30       | 2+2 | 1        | 3800 - 6500       | L |  | 1        | o | 68255130     |
| 200      | 60        | 30       | 2+2 | 2        | 3800 - 6500       | R |  | 1        | o | 68255230     |
| 200      | 60        | 40       | 2+2 | 1        | 3800 - 6500       | L |  | 1        | o | 68255140     |
| 200      | 60        | 40       | 2+2 | 2        | 3800 - 6500       | R |  | 1        | o | 68255240     |
| 200      | 60        | 50       | 2+2 | 1        | 3800 - 6500       | L |  | 1        | o | 68255150     |
| 200      | 60        | 50       | 2+2 | 2        | 3800 - 6500       | R |  | 1        | o | 68255250     |

| Omkeermessen            | Afmeting [mm] | Geschikt voor                | L | VE [St.] | V | Bestelnummer |
|-------------------------|---------------|------------------------------|---|----------|---|--------------|
| Profiel-vlakmessen A1   | 60x12x1,5     | 68255130, 68255140, 68255150 | L | 6        | o | 62556011     |
| Profiel-vlakmessen A2   | 60x12x1,5     | 68255230, 68255240, 68255250 | R | 6        | o | 62556012     |
| Profiel-vlakmessen B1   | 60x12x1,5     | 68255130, 68255140, 68255150 | L | 6        | o | 62556021     |
| Profiel-vlakmessen B2   | 60x12x1,5     | 68255230, 68255240, 68255250 | R | 6        | o | 62556022     |
| Profiel-vlakmessen C1   | 60x12x1,5     | 68255130, 68255140, 68255150 | L | 6        | o | 62556031     |
| Profiel-vlakmessen C2   | 60x12x1,5     | 68255230, 68255240, 68255250 | R | 6        | o | 62556032     |
| Profiel-omtrekmessen T1 | 20x12x1,5     | 68255130, 68255140, 68255150 | L | 6        | o | 62556023     |
| Profiel-omtrekmessen T2 | 20x12x1,5     | 68255230, 68255240, 68255250 | R | 6        | o | 62556024     |
| Profiel-omtrekmessen V1 | 20x12x1,5     | 68255130, 68255140, 68255150 | L | 6        | o | 62556013     |
| Profiel-omtrekmessen V2 | 20x12x1,5     | 68255230, 68255240, 68255250 | R | 6        | o | 62556014     |

## 5540 Vlakmeskoppen Silverline - Tekening

Profielcombinaties

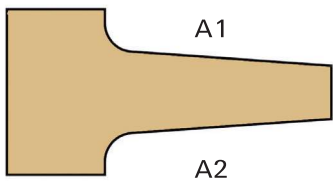

**A**

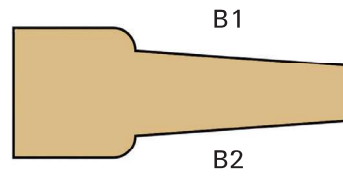

**B**

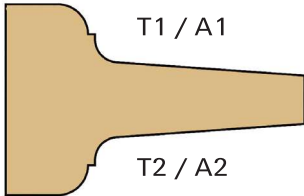

**A/T**

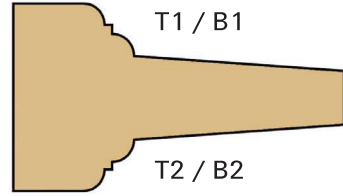

**BT**

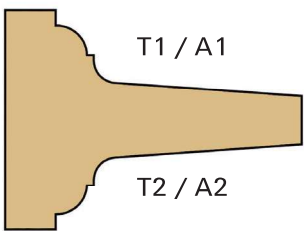

**A/T**

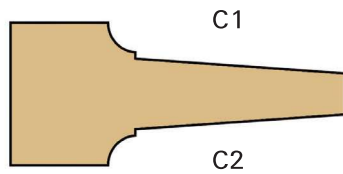

**C**

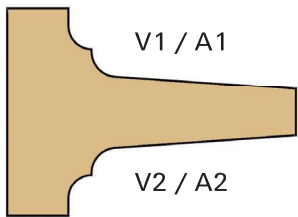

**A/V**

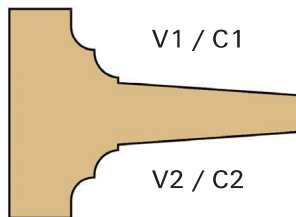

**CV**

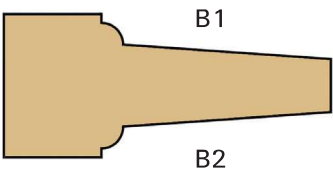

**B**

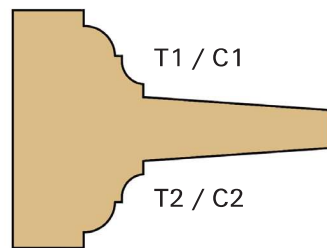

**CT**

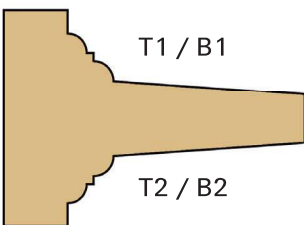

**B/T**

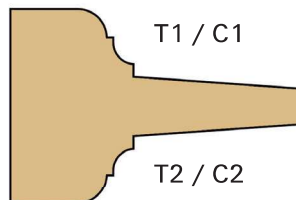

**CT**

## HW 1547 Universele Euro-Profiel frezen - Silverline voor messen nr. 40 en 50

Product



Tekening

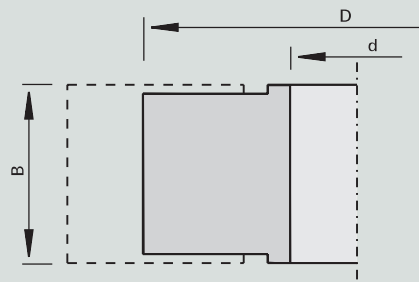

Machine



Toepassing



Uitvoering



STAHL

HW  
TCw25

MAN

Machine / gebruiksaanwijzing

- Tafelfreesmachines (handmatige toevoer)
- Voor het profiel aanbrengen van zachte en harde houtsoorten (massief hout onverlijmd)

Uitvoering

- Body van staal
- Compacte messen en afwijzerbevestiging
- Spaandiktebegrensd en terugslagarm
- Messen van SP-staal
- Frees B= 40 mm alleen mesbreedte van 40 mm gebruiken
- Frees B= 40/50 mm geschikt voor mesbreedtes van 40 mm en 50 mm

Voordelen

Informatie - Tip



- Profielmes met bijbehorende afwijzers altijd paarsgewijs gebruiken
- Max. profieldiepte 15 mm
- Mes- en afwijzer dikte 4 mm andere diktes niet toegestaan
- Mes en afwijzer niet bij de leveringsomvang inbegrepen, deze vindt u op onze homepage [www.stehle.nl](http://www.stehle.nl)

Producteigenschappen

Bestelinformatie

| Ø D [mm] | B [mm] | Ø d [mm] | Z   | nmin-nmax [min-1] | VE [St.] | V | Bestelnummer |
|----------|--------|----------|-----|-------------------|----------|---|--------------|
| 96       | 40     | 30       | 2   | 7800-10000        | 1        | o | 69563162     |
| 116      | 40/50  | 30       | 2   | 5000-8000         | 1        | o | 69563160     |
| 116      | 40/50  | 40       | 2+2 | 5000-8000         | 1        | o | 69563163     |
| 116      | 40/50  | 50       | 2   | 5000-8000         | 1        | o | 69563161     |

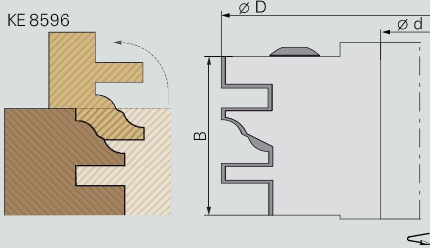
# HW 5567 Contraprofiel frezen

|  |  |  |   |   |
|--|--|--|---|---|
| <p>Product</p>  | <p>Tekening</p>  | <p>Machine</p>  | <p>Toepassing</p>  | <p>Uitvoering</p> <ul style="list-style-type: none"> <li>ALU</li> <li>HW TC06</li> <li>MAN</li> </ul> |
|--|--|--|---|---|

|   |  |  |   |
|---|--|--|---|
| <p>Machine / gebruiksaanwijzing</p> <ul style="list-style-type: none"> <li>Tafelfreesmachines</li> <li>Voor het frezen van langs- en contraprofielen bij deuren, meubels en sponningen in massief hout en plaatmateriaal op basis van hout</li> </ul> | <p>Uitvoering</p> <ul style="list-style-type: none"> <li>Body van hoogwaardige ALU-legering</li> <li>Snijkanen asparallel</li> <li>Tandbezetting: HW TC06</li> <li>Spaandiktebegrensd</li> </ul> | <p>Voordelen</p> <ul style="list-style-type: none"> <li>Freeskop voor het opspannen van verschillende profielmesses</li> <li>Eenvoudig verwisselen van messes</li> </ul> | <p>Informatie - Tip</p> <ul style="list-style-type: none"> <li>Contra-profiel-garnituur met profiel KE8596</li> <li>Alternatieve profielen niet inbegrepen</li> </ul> |
|---|--|--|---|

| Producteigenschappen        |        |          |               |                   |               | Bestelinformatie |              |              |
|-----------------------------|--------|----------|---------------|-------------------|---------------|------------------|--------------|--------------|
| Ø D [mm]                    | B [mm] | Ø d [mm] | Z             | nmin-nmax [min-1] |               | VE [St.]         | V            | Bestelnummer |
| 130                         | 40     | 30       | 2             | 6000-12000        |               | 1                |              | 50664637     |
| Omkeermesses                |        |          |               |                   | Snijmateriaal | VE [St.]         | V            | Bestelnummer |
| Profiel-omkeermesses KE7826 |        |          |               |                   | TC06          | 2                |              | 50687826     |
| Profiel-omkeermesses KE7828 |        |          |               |                   | TC06          | 6                | s            | 50687828     |
| Profiel-omkeermesses KE7824 |        |          |               |                   | TC06          | 6                | s            | 50687824     |
| Profiel-omkeermesses KE8598 |        |          |               |                   | TC06          | 6                | s            | 50688598     |
| Profiel-omkeermesses KE8596 |        |          |               |                   | TC06          | 6                | s            | 50688596     |
| Toebehoren                  |        |          | Afmeting [mm] |                   | VE [St.]      | V                | Bestelnummer |              |
| Drukstuk                    |        |          | B=36          |                   | 2             | #                | 50773906     |              |
| Draadstift                  |        |          | M6x16 SW3     |                   | 10            |                  | 001617       |              |
| Schroevendraaier            |        |          | SW3x100       |                   | 1             |                  | 166090       |              |

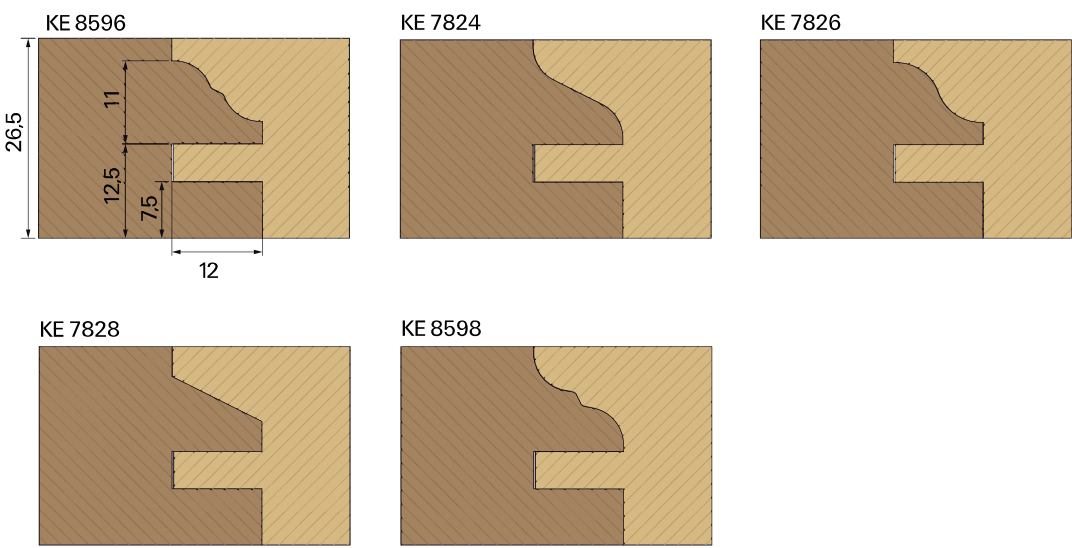

# HW 5554 Contraprofielgarnituur

Product



Tekening

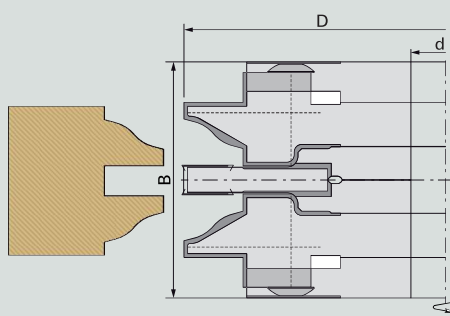

Machine



Toepassing



Uitvoering

- HW TC05
- HW TC06
- HW TCw30
- MAN

Machine / gebruiksaanwijzing

- Tafelfreesmachines
- Voor het frezen van profiel en contraprofiel in massief hout en plaatmateriaal op basis van hout

Uitvoering

- Snijkanten asparallel
- Tandbezetting: HW
- Gereedschapset waarin meerdere profielen mogelijk zijn

Voordelen

- Freeskop voor het opspannen van verschillende profielmessen
- Universeel bruikbaar, lage gereedschapkosten

Informatie - Tip

- Contraprofiel-garnituur met profiel A
- Alternatieve profielen niet inbegrepen

Producteigenschappen

Bestelinformatie

| Ø D [mm]               | B [mm] | Ø d [mm] | Z             | Profiel  | nmin-nmax [min-1] | VE [St.] | V Bestelnummer |               |          |                |
|------------------------|--------|----------|---------------|----------|-------------------|----------|----------------|---------------|----------|----------------|
| 160                    | 37-48  | 30       | 2             | A        | 4800-8200         | 1        | 50664655       |               |          |                |
| Omkeermessen           |        |          |               | Profiel  | B [mm]            | H [mm]   | S [mm]         | Snijmateriaal | VE [St.] | V Bestelnummer |
| Omkeermessen           |        |          |               |          | 7,5               | 12       | 1,5            | TC05          | 10       | 50820007       |
| Omkeermessen           |        |          |               |          | 14                | 14       | 2,0            | TCw30         | 10       | 50820014       |
| Toebehoren             |        |          | Afmeting [mm] | VE [St.] | V Bestelnummer    |          |                |               |          |                |
| Draadstift             |        |          | M6x16 SW3     | 10       | 001617            |          |                |               |          |                |
| Verzonken kopschroeven |        |          | M5x6 T20      | 10       | 176199            |          |                |               |          |                |
| Schroevendraaier       |        |          | SW3x100       | 1        | 166090            |          |                |               |          |                |
| Schroevendraaier       |        |          | T20x100       | 1        | 166092            |          |                |               |          |                |

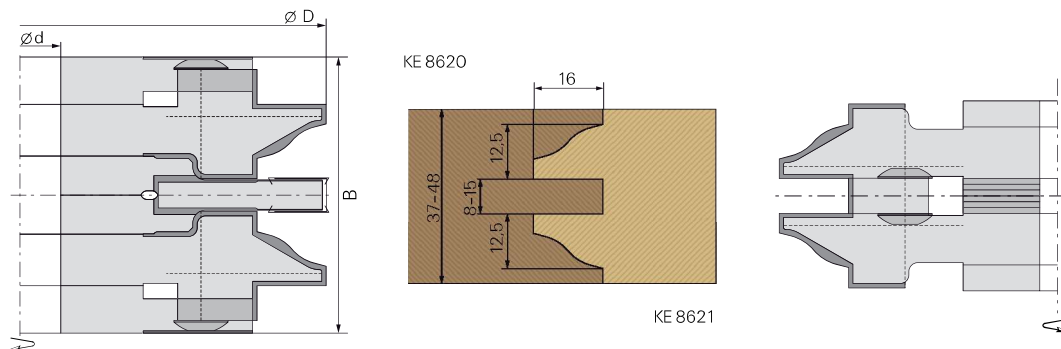

KE 8628

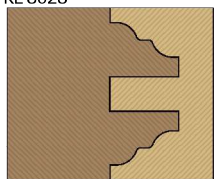

KE 8629

KE 8624

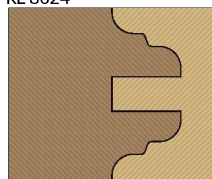

KE 8626

KE 8626

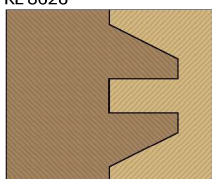





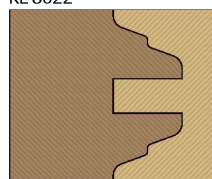

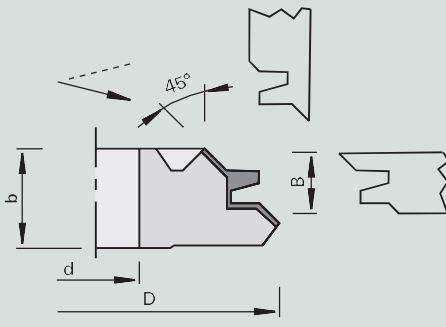

KE 8627

KE 8622



KE 8623

## HW 5556 Verstek-verlijmfrezen

|  |  |  |
|--|--|--|
| <p>Product</p>  | <p>Tekening</p>  | <p>Machine</p>   <p>Toepassing</p>   <p>Uitvoering</p>  <p>ALU</p>  <p>HW TCw25</p>  <p>MAN</p> |
|--|--|--|

|   |  |  |   |
|---|--|--|---|
| <p>Machine / gebruiksaanwijzing</p> <ul style="list-style-type: none"> <li>• Stationaire machines</li> <li>• Tafelfreesmachines</li> <li>• Voor het frezen van verstekverbindingen in massief hout en plaatmateriaal op basis van hout</li> </ul> | <p>Uitvoering</p> <ul style="list-style-type: none"> <li>• Body van hoogwaardige ALU-legering</li> <li>• Snijkanten asparallel</li> <li>• n = 4.600 - 7.800 (omw/min)</li> </ul> | <p>Voordelen</p> <ul style="list-style-type: none"> <li>• Constante profielnauwkeurigheid door omkeermessen</li> <li>• Profiel instelbaar door ingebouwde afstandsringen onder de sponning- en fasemessen</li> </ul> | <p>Informatie - Tip</p> <ul style="list-style-type: none"> <li>• Toepassing tegenlopend</li> <li>• Houtdikte ong. 15 mm tot maximaal 28 mm</li> </ul> |
|---|--|--|---|

| Producteigenschappen                          |        |        |               |               |                   | Bestelinformatie |                    |
|---|--------|--------|---------------|---------------|-------------------|------------------|--------------------|
| Ø D [mm]                                      | B [mm] | b [mm] | Ø d [mm]      | Z             | nmin-nmax [min-1] | VE [St.]         | V Bestelnummer     |
| 174   | 26     | 49     | 30            | 2+2           | 4600-7800         | 1                | 50664636           |
| Omkeermessen                                  |        |        | [mm]          | Snijmateriaal |                   | VE [St.]         | V Bestelnummer     |
| Sponning-fasemes                              |        |        | 16x34x5       | TCw30         |                   | 5                | 184275 <b>NEUW</b> |
| Verlijmingsprofiel omkeermessen HW in verstek |        |        | 39,5x12x1,5   | TCw20         |                   | 10               | 165916 <b>NEUW</b> |
| Toebehoren                                    |        |        | Afmeting [mm] |               |                   | VE [St.]         | V Bestelnummer     |
| Opspanstukken                                 |        |        | 12x8,5/M8L    |               |                   | 2                | 180357             |
| Schroef                                       |        |        | M8x26 SW4     |               |                   | 10               | 180340             |
| Schroef                                       |        |        | M5x10,8 T15   |               |                   | 10               | 180840             |
| Schroevendraaier                              |        |        | SW4x100       |               |                   | 1                | 166091             |
| Schroevendraaier                              |        |        | T15x100       |               |                   | 1                | 180470             |

# HW 1534-2 Verlijmprofielfrezen

Product



Tekening

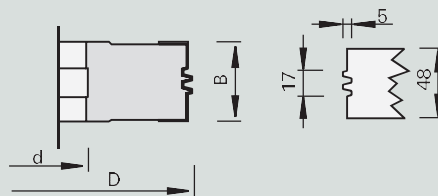

Machine



Toepassing



Uitvoering



Machine / gebruiksaanwijzing

- Stationaire machines
- Tafelfreesmachines
- Voor het frezen van breedteverbindingen in massief hout

Uitvoering

- Snijkanten asparallel
- Tandbezetting: HW TC05
- $n = 5.700 - 9.800$  (omw/min)

Voordelen

- Constante profielnauwkeurigheid door omkeermessen

Informatie - Tip

- Toepassing tegenlopend
- Passing van de verbindingen kan door zijdelijngs verschuiven van de omkeermessen via verschillende instellingen zelf bepaald worden (zie reserveonderdelen)
- Basisinstelling bij levering 0,3 mm basisspeling in de vingerlas

Producteigenschappen

Bestelinformatie

| Ø D [mm]                   | B [mm] | Ø d [mm]      | Ø dmax [mm] | Z            | H [mm] | Profiel |          | VE [St.]      | V            | Bestelnummer |              |
|----------------------------|--------|---------------|-------------|--------------|--------|---------|----------|---------------|--------------|--------------|--------------|
| 135                        | 40     | 30            | 50          | 2            | 9-38   | 470     |          | 1             | s            | 50663047     |              |
| 135                        | 50     | 30            | 50          | 2            | 17-48  | 471     |          | 1             | #            | 50663025     |              |
| 135                        | 60     | 30            | 50          | 2            | 25-58  | 472     |          | 1             | s            | 50663026     |              |
| Omkeermessen               |        |               |             | Profiel      | B [mm] | H [mm]  | S [mm]   | Snijmateriaal | VE [St.]     | V            | Bestelnummer |
| Profiel-omkeermessen KB450 |        |               |             | 470          | 40     | 23      | 2.0      | TC05          | 6            | s            | 50690450     |
| Profiel-omkeermessen KB374 |        |               |             | 471          | 50     | 23      | 2.0      | TC05          | 2            |              | 50820003     |
| Profiel-omkeermessen KB372 |        |               |             | 472          | 60     | 23      | 2.0      | TC05          | 4            |              | 50820004     |
| Toebehoren                 |        | Afmeting [mm] |             | Passend voor |        |         | VE [St.] | V             | Bestelnummer |              |              |
| Drukstukken                |        | 38x11x6       |             | 50663047     |        |         | 2        |               | 50005542     |              |              |
| Drukstukken                |        | 48x11x6       |             | 50663025     |        |         | 2        |               | 50591365     |              |              |
| Drukstukken                |        | 58x11x6       |             | 50663026     |        |         | 2        |               | 180434       |              |              |
| Opspanstukken              |        | 12x8,5/M8L    |             | Voor alle    |        |         | 2        |               | 180357       |              |              |
| Schroef                    |        | M8x26 SW4     |             | Voor alle    |        |         | 10       |               | 180340       |              |              |
| Schroevendraaier           |        | SW4x100       |             | Voor alle    |        |         | 1        |               | 166091       |              |              |
| Toebehoren                 |        | Afmeting [mm] |             |              |        |         | VE [St.] | V             | Bestelnummer |              |              |
| Instellingen               |        | 0,1 + 0,15    |             |              |        |         | 1        |               | 180435       |              |              |
| Instellingen               |        | 0,15 + 0,2    |             |              |        |         | 1        |               | 180436       |              |              |
| Instellingen               |        | 0,2 + 0,25    |             |              |        |         | 1        |               | 180437       |              |              |
| Instellingen               |        | 0,25 + 0,3    |             |              |        |         | 1        |               | 180438       |              |              |
| Instellingen               |        | 0,3 + 0,35    |             |              |        |         | 1        |               | 180439       |              |              |

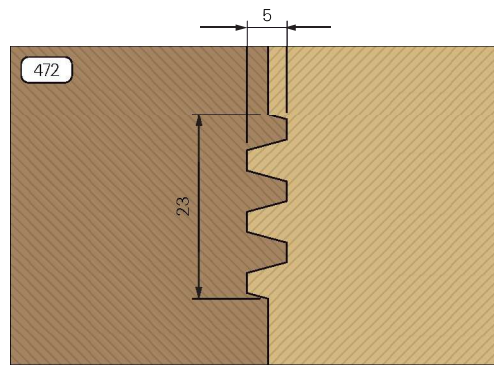
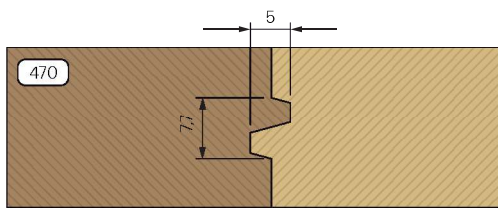
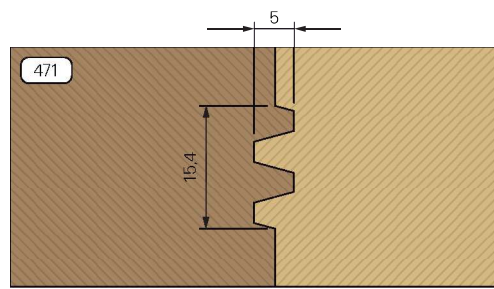
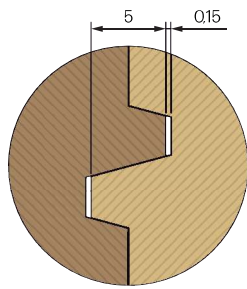



# HW 5570 Spiraal schaafkoppen

Met HW-omkeermes

Product



Tekening

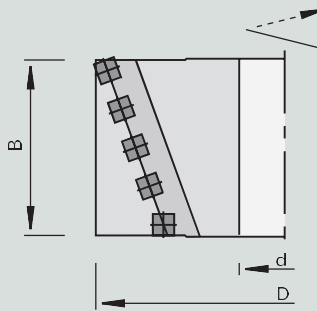

Machine



Toepassing



Uitvoering



Machine / gebruiksaanwijzing

- Tafelfreesmachine
- Stationaire freescentra
- Voor het gladmaken, voorschaven en naschaven van massief hout

Uitvoering

- Met vierzijdig snijdende convexe omkeermessen
- Spiraalvormig patroon van de omkeermessen en snijverdeling
- Body van gelegeerd aluminium

Voordelen

- Gemakkelijk verspanen, minimale snijdruk en geluidsarm



Informatie - Tip

- Voor afwerksnede
- Andere maten op aanvraag

Producteigenschappen

| Ø D [mm]                | B [mm] | Ø d [mm] | Z             | nmax [min-1] |        |        |        |               | VE [St.] | V | Bestelnummer |
|-------------------------|--------|----------|---------------|--------------|--------|--------|--------|---------------|----------|---|--------------|
| 125                     | 100    | 40       | 2+2           | 12000        |        |        |        |               | 1        | s | 50665050     |
| 125                     | 130    | 40       | 2+2           | 12000        |        |        |        |               | 1        | s | 50665101     |
| 125                     | 170    | 40       | 2+2           | 12000        |        |        |        |               | 1        | s | 50665102     |
| 125                     | 230    | 40       | 2+2           | 12000        |        |        |        |               | 1        | s | 50665103     |
| 125                     | 240    | 40       | 2+2           | 12000        |        |        |        |               | 1        | s | 50665104     |
| Omkeermessen            |        |          |               |              | B [mm] | H [mm] | S [mm] | Snijmateriaal | VE [St.] | V | Bestelnummer |
| Omkeermessen (gewelfd)  |        |          |               |              | 15     | 15     | 2.5    | TCw20         | 10       |   | 50820017     |
| Toebehoren              |        |          | Afmeting [mm] |              |        |        |        |               | VE [St.] | V | Bestelnummer |
| Verzonken kop-schroeven |        |          | M5x15,5 T20   |              |        |        |        |               | 10       |   | 182112       |
| Schroevendraaier        |        |          | T20x100       |              |        |        |        |               | 1        |   | 166092       |

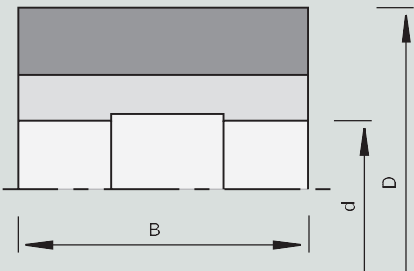
# HS 556-1 Schaafkoppen

|  |  |  |   |   |
|--|--|--|---|---|
| <p>Product</p>  | <p>Tekening</p>  | <p>Machine</p>  | <p>Toepassing</p>  | <p>Uitvoering</p> <ul style="list-style-type: none"> <li style="border: 1px solid black; padding: 2px; text-align: center;">HS</li> <li style="border: 1px solid black; padding: 2px; text-align: center;">HSSL</li> <li style="border: 1px solid black; padding: 2px; text-align: center;">HW</li> <li style="border: 1px solid black; padding: 2px; text-align: center;">MEC</li> </ul> |
|--|--|--|---|---|

|   |   |                  |   |
|---|---|------------------|---|
| <p>Machine / gebruiksaanwijzing</p> <ul style="list-style-type: none"> <li>• Meerzijdige schaafmachines</li> <li>• Voor het schaven van massief hout</li> </ul> | <p>Uitvoering</p> <ul style="list-style-type: none"> <li>• n-max = 9.000 (omw/min)</li> </ul> | <p>Voordelen</p> | <p>Informatie - Tip</p> <ul style="list-style-type: none"> <li>• Voorzien van HS-messen (18 %) 30 x 3 mm</li> <li>• Alternatief snijmateriaal: ST voor soorten zacht- en hardhout; HW voor hardhout en exotische houtsoorten</li> </ul> |
|---|---|------------------|---|

| Producteigenschappen     |        |          |                        | Bestelinformatie |   |              |
|--------------------------|--------|----------|------------------------|------------------|---|--------------|
| Ø D [mm]                 | B [mm] | Ø d [mm] | Z                      | VE [St.]         | V | Bestelnummer |
| 125                      | 80     | 40       | 4                      | 1                | o | 50561046     |
| 125                      | 100    | 40       | 4                      | 1                | o | 50561038     |
| 125                      | 130    | 40       | 4                      | 1                | o | 50561035     |
| 125                      | 150    | 40       | 4                      | 1                | o | 50561036     |
| 125                      | 180    | 40       | 4                      | 1                | o | 50561037     |
| 125                      | 240    | 40       | 4                      | 1                | o | 50561054     |
| Toebehoren               |        |          | Afmeting [mm]          | VE [St.]         | V | Bestelnummer |
| Drukstuk                 |        |          | B=80                   | 2                | o | 179205       |
| Drukstuk                 |        |          | B=100                  | 2                | o | 181191       |
| Drukstuk                 |        |          | B=130                  | 2                | o | 179198       |
| Drukstuk                 |        |          | B=150                  | 2                | o | 179199       |
| Drukstuk                 |        |          | B=180                  | 2                | o | 179200       |
| Draadstift               |        |          | M10x25 DIN EN ISO 4028 | 10               |   | 168108       |
| Haakse schroevendraaiers |        |          | SW5 DIN ISO 2936       | 1                |   | 009674       |
| Drukstuk                 |        |          | B=240                  | 2                | o | 50562677     |

# HS 520-1 Hydro-schaafkoppen

Product



Tekening

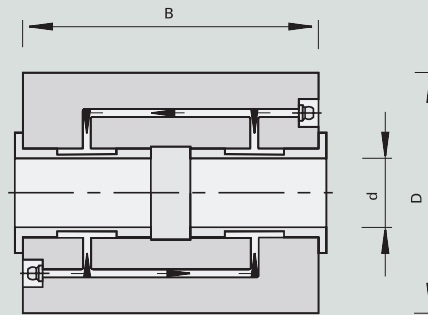

Machine



Toepassing



Uitvoering

- HS
- HSL
- HW
- MEC

Machine / gebruiksaanwijzing

- Hydro-profielfreesmachines
- Voor het schaven van massief hout

Uitvoering

Voordelen

- Hoge rondloopprecisie en rustige loop door spelingsvrije centering via Hydro-opspanning, systeem Weinig
- Hoge aanvoersnelheid bij uitstekende snijkwaliteit

Informatie - Tip

- Voorzien van HS-messen 30 x 3 mm
- Alternatief snijmateriaal: ST voor soorten zacht- en hardhout; HW voor hardhout en exotische houtsoorten
- Vetrnippels op de diameter op aanvraag

Producteigenschappen

Bestelinformatie

| Ø D [mm] | B [mm] | Ø d [mm] | Z  | n <sub>max</sub> [min <sup>-1</sup> ] | VE [St.] | V | Bestelnummer |
|----------|--------|----------|----|---------------------------------------|----------|---|--------------|
| 143      | 60     | 40       | 4  | 8500                                  | 1        | s | 58562686     |
| 143      | 130    | 40       | 4  | 8500                                  | 1        | s | 58562689     |
| 143      | 230    | 40       | 4  | 8500                                  | 1        | s | 58562990     |
| 163      | 60     | 50       | 4  | 6000                                  | 1        | s | 58562687     |
| 163      | 100    | 50       | 4  | 6000                                  | 1        | s | 58562691     |
| 163      | 130    | 50       | 4  | 6000                                  | 1        | s | 58562741     |
| 163      | 130    | 50       | 4  | 6000                                  | 1        | s | 58562693     |
| 163      | 180    | 50       | 4  | 6000                                  | 1        | s | 58562700     |
| 163      | 230    | 50       | 4  | 6000                                  | 1        | s | 58562695     |
| 163      | 260    | 50       | 4  | 6000                                  | 1        | s | 58562697     |
| 163      | 310    | 50       | 4  | 6000                                  | 1        | s | 58562701     |
| 163      | 60     | 50       | 6  | 6000                                  | 1        | s | 58562688     |
| 163      | 100    | 50       | 6  | 6000                                  | 1        | s | 58562692     |
| 163      | 130    | 50       | 6  | 6000                                  | 1        | s | 58562742     |
| 163      | 150    | 50       | 6  | 6000                                  | 1        | s | 58562694     |
| 163      | 180    | 50       | 6  | 6000                                  | 1        | s | 58562702     |
| 163      | 230    | 50       | 6  | 6000                                  | 1        | s | 58562696     |
| 163      | 260    | 50       | 6  | 6000                                  | 1        | s | 58562698     |
| 163      | 310    | 50       | 6  | 6000                                  | 1        | s | 58562703     |
| 163      | 60     | 50       | 8  | 6000                                  | 1        | s | 58562738     |
| 163      | 100    | 50       | 8  | 6000                                  | 1        | s | 58562740     |
| 163      | 130    | 50       | 8  | 6000                                  | 1        | s | 58562739     |
| 163      | 150    | 50       | 8  | 6000                                  | 1        | s | 58562743     |
| 163      | 180    | 50       | 8  | 6000                                  | 1        | s | 58562750     |
| 163      | 230    | 50       | 8  | 6000                                  | 1        | s | 58562744     |
| 163      | 260    | 50       | 8  | 6000                                  | 1        | s | 58562745     |
| 163      | 310    | 50       | 8  | 6000                                  | 1        | s | 58562751     |
| 203      | 100    | 50       | 12 | 6000                                  | 1        | s | 58562752     |
| 203      | 150    | 50       | 12 | 6000                                  | 1        | s | 58562753     |
| 203      | 230    | 50       | 12 | 6000                                  | 1        | s | 58562754     |
| 203      | 260    | 50       | 12 | 6000                                  | 1        | s | 58562755     |
| 203      | 310    | 50       | 12 | 6000                                  | 1        | s | 58562756     |
| 203      | 330    | 50       | 12 | 6000                                  | 1        | s | 58562757     |

Toebehoren

Afmeting [mm]

| Toebehoren       | Afmeting [mm]          | VE [St.] | V | Bestelnummer |
|------------------|------------------------|----------|---|--------------|
| Draadstift       | M12x25 DIN EN ISO 4028 | 10       |   | 181466       |
| Schroevendraaier | SW6x200                | 1        |   | 167817       |
| Vetspuiten       |                        | 1        |   | 163706       |
| Vetpatronen      |                        | 1        |   | 163707       |

# HS 569 Schaafmes, HSS - 18%

Product



Tekening

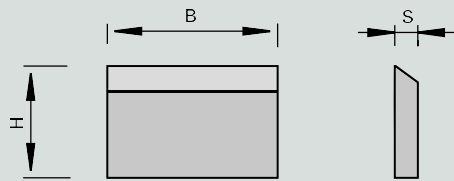

Machine



Toepassing



Uitvoering



3-0-1

HS 18%



- |   |   |   |  |
|---|---|---|--|
| <p><b>Machine / gebruiksaanwijzing</b></p> <ul style="list-style-type: none"> <li>• Voor toepassing bij schaafmes-koppen</li> <li>• Eveneens geschikt voor thermoplastische grondstoffen als PE, PP, PVC</li> </ul> | <p><b>Uitvoering</b></p> <ul style="list-style-type: none"> <li>• Snijmateriaal High performance snelstaal voor de bewerking van zacht hout</li> <li>• Wighoek 40°</li> </ul> | <p><b>Voordelen</b></p> <ul style="list-style-type: none"> <li>• HSS-18% voor hoge standtijden</li> </ul> | <p><b>Informatie - Tip</b></p> <ul style="list-style-type: none"> <li>• Uit veiligheidsoverwegingen als messen en steunplaten met hetzelfde gewicht (verpakkingseenheid VE) tegenover elkaar monteren.</li> <li>• Verpakkingseenheid 2 stuk</li> </ul> |
|---|---|---|--|

| Producteigenschappen |        |        | Bestelinformatie |   |              |  |
|----------------------|--------|--------|------------------|---|--------------|--|
| B [mm]               | H [mm] | S [mm] | VE [St.]         | V | Bestelnummer |  |
| 60                   | 30     | 3      | 2                | s | 58400131     |  |
| 80                   | 30     | 3      | 2                | s | 58400132     |  |
| 100                  | 30     | 3      | 2                |   | 58400133     |  |
| 120                  | 30     | 3      | 2                | s | 58400134     |  |
| 130                  | 30     | 3      | 2                |   | 58400135     |  |
| 150                  | 30     | 3      | 2                |   | 58400136     |  |
| 160                  | 30     | 3      | 2                |   | 58400137     |  |
| 170                  | 30     | 3      | 2                |   | 58400161     |  |
| 180                  | 30     | 3      | 2                |   | 58400138     |  |
| 180                  | 35     | 3      | 2                | s | 58400201     |  |
| 210                  | 30     | 3      | 2                | s | 58400162     |  |
| 230                  | 30     | 3      | 2                |   | 58400139     |  |
| 240                  | 30     | 3      | 2                |   | 58400206     |  |
| 260                  | 30     | 3      | 2                |   | 58400163     |  |
| 300                  | 30     | 3      | 2                |   | 58400140     |  |
| 300                  | 35     | 3      | 2                |   | 58400202     |  |
| 310                  | 30     | 3      | 2                |   | 58400147     |  |
| 310                  | 35     | 3      | 2                | s | 58400187     |  |
| 320                  | 30     | 3      | 2                |   | 58400205     |  |
| 330                  | 30     | 3      | 2                | s | 58400141     |  |
| 350                  | 30     | 3      | 2                |   | 58400198     |  |
| 350                  | 35     | 3      | 2                | s | 58400188     |  |
| 400                  | 30     | 3      | 2                |   | 58400170     |  |
| 400                  | 35     | 3      | 2                | s | 58400171     |  |
| 410                  | 30     | 3      | 2                |   | 58400149     |  |
| 410                  | 35     | 3      | 2                |   | 58400158     |  |
| 420                  | 30     | 3      | 2                |   | 58400142     |  |
| 420                  | 35     | 3      | 2                | s | 58400190     |  |
| 450                  | 30     | 3      | 2                |   | 58400150     |  |
| 460                  | 30     | 3      | 2                | s | 58400151     |  |
| 460                  | 35     | 3      | 2                | s | 58400192     |  |
| 500                  | 30     | 3      | 2                |   | 58400143     |  |
| 500                  | 35     | 3      | 2                |   | 58400196     |  |
| 510                  | 30     | 3      | 2                |   | 58400152     |  |
| 510                  | 35     | 3      | 2                |   | 58400159     |  |
| 520                  | 30     | 3      | 2                |   | 58400184     |  |
| 530                  | 30     | 3      | 2                |   | 58400144     |  |
| 530                  | 35     | 3      | 2                |   | 58400166     |  |
| 600                  | 30     | 3      | 2                | s | 58400165     |  |
| 600                  | 35     | 3      | 2                |   | 58400193     |  |
| 610                  | 30     | 3      | 2                |   | 58400153     |  |
| 610                  | 35     | 3      | 2                |   | 58400160     |  |

| Producteigenschappen |        |        |  | Bestelinformatie |   |              |
|----------------------|--------|--------|--|------------------|---|--------------|
| B [mm]               | H [mm] | S [mm] |  | VE [St.]         | V | Bestelnummer |
| 630                  | 30     | 3      |  | 2                |   | 58400145     |
| 630                  | 35     | 3      |  | 2                |   | 58400194     |
| 635                  | 35     | 3      |  | 2                | s | 58400195     |
| 640                  | 30     | 3      |  | 2                |   | 58400154     |
| 640                  | 35     | 3      |  | 2                |   | 58400167     |
| 710                  | 30     | 3      |  | 2                | s | 58400155     |
| 710                  | 35     | 3      |  | 2                |   | 58400179     |
| 810                  | 30     | 3      |  | 2                |   | 58400156     |
| 810                  | 35     | 3      |  | 2                | s | 58400164     |
| 840                  | 30     | 3      |  | 2                |   | 58400157     |
| 1000                 | 30     | 3      |  | 2                | s | 58400185     |
| 1000                 | 35     | 3      |  | 2                |   | 58400168     |
| 1040                 | 25     | 3      |  | 2                | s | 58400183     |
| 1050                 | 30     | 3      |  | 2                |   | 58400174     |
| 1050                 | 35     | 3      |  | 2                |   | 58400175     |

## HW 569 Schaafmes HW belegd

Product



Tekening

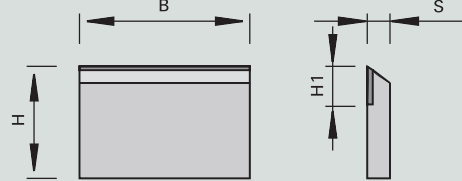

Machine



Toepassing



Uitvoering





- |  |   |                  |  |
|--|---|------------------|--|
| <p>Machine / gebruiksaanwijzing</p> <ul style="list-style-type: none"> <li>• Voor toepassing in schaafoorkoppen</li> </ul> | <p>Uitvoering</p> <ul style="list-style-type: none"> <li>• Snijmateriaal HW voor de bewerking van hardhout</li> </ul> | <p>Voordelen</p> | <p>Informatie - Tip</p> <ul style="list-style-type: none"> <li>• Verpakkingseenheid 2 stuks</li> </ul> |
|--|---|------------------|--|

| Producteigenschappen |        |        |         | Bestelinformatie |   |              |
|----------------------|--------|--------|---------|------------------|---|--------------|
| B [mm]               | H [mm] | S [mm] | H1 [mm] | VE [St.]         | V | Bestelnummer |
| 60                   | 30     | 3.0    | 11      | 2                | s | 50400021     |
| 100                  | 30     | 3.0    | 11      | 2                | s | 50400023     |
| 120                  | 30     | 3.0    | 11      | 2                | s | 50400024     |
| 130                  | 30     | 3.0    | 11      | 2                | s | 50400025     |
| 150                  | 30     | 3.0    | 11      | 2                | s | 50400026     |
| 160                  | 30     | 3.0    | 11      | 2                | s | 50400036     |
| 170                  | 30     | 3.0    | 11      | 2                | s | 50400027     |
| 180                  | 30     | 3.0    | 11      | 2                | s | 50400028     |
| 210                  | 30     | 3.0    | 11      | 2                | s | 50400029     |
| 230                  | 30     | 3.0    | 11      | 2                | s | 50400030     |
| 260                  | 30     | 3.0    | 11      | 2                | s | 50400031     |
| 310                  | 30     | 3.0    | 11      | 2                | s | 50400032     |
| 310                  | 35     | 3.0    | 11      | 2                | s | 50400073     |
| 400                  | 35     | 3.0    | 11      | 2                | s | 50400077     |
| 410                  | 30     | 3.0    | 11      | 2                | s | 50400033     |
| 410                  | 35     | 3.0    | 11      | 2                | s | 50400074     |
| 460                  | 30     | 3.0    | 11      | 2                | s | 50400078     |
| 500                  | 30     | 3.0    | 11      | 2                | s | 50400079     |
| 510                  | 30     | 3.0    | 11      | 2                | s | 50400034     |
| 510                  | 35     | 3.0    | 11      | 2                | s | 50400075     |
| 600                  | 30     | 3.0    | 11      | 2                | s | 50400080     |
| 610                  | 30     | 3.0    | 11      | 2                | s | 50400035     |
| 640                  | 30     | 3.0    | 11      | 2                | s | 50400083     |
| 810                  | 30     | 3.0    | 11      | 2                | s | 50400063     |

## HW 125 Rugvertande profielfrees

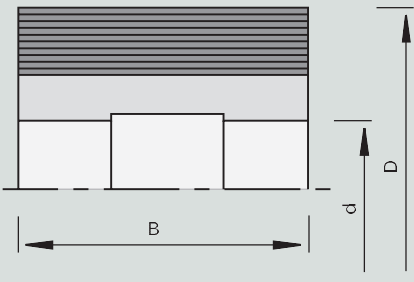
Product Tekening Machine Toepassing Uitvoering

**HS**

**MEC**

- |  |  |  |  |
|--|--|--|--|
| <p><b>Machine / gebruiksaanwijzing</b></p> <ul style="list-style-type: none"> <li>• Tafelfreesmachine</li> <li>• Voor het profileren van massief hout</li> </ul> | <p><b>Uitvoering</b></p> <ul style="list-style-type: none"> <li>• Spaanhoek 25 graden</li> <li>• Wordt zonder messen geleverd</li> </ul> | <p><b>Voordelen</b></p> <ul style="list-style-type: none"> <li>• Hoogste profielnauwkeurigheid en oppervlaktekwaliteit door slijpen van de messen in de messenkop</li> </ul> | <p><b>Informatie - Tip</b></p> <ul style="list-style-type: none"> <li>• Vormgesloten messenopspanning door zeer nauwkeurige vertanding 60 graden, verdeling 1,6 mm</li> <li>• Messen nastelbaar</li> <li>• Profieldiepte en buitendiameter zie tabel</li> <li>• Voor blankets met rugvertanding met <math>d = 8, 10\text{mm}</math></li> <li>• Inhoud van de verpakking: freeskop met drukstukken</li> </ul> |
|--|--|--|--|

| Producteigenschappen |        |                        |   | Bestelinformatie |   |              |
|----------------------|--------|------------------------|---|------------------|---|--------------|
| Ø D [mm]             | B [mm] | Ø d [mm]               | Z | VE [St.]         | V | Bestelnummer |
| 122                  | 40     | 40                     | 4 | 1                | s | 50822780     |
| 122                  | 60     | 40                     | 4 | 1                | s | 50822781     |
| 122                  | 80     | 40                     | 4 | 1                | s | 50822782     |
| 122                  | 100    | 40                     | 4 | 1                | s | 50822783     |
| 122                  | 130    | 40                     | 4 | 1                | s | 50822784     |
| 122                  | 150    | 40                     | 4 | 1                | s | 50822785     |
| 122                  | 180    | 40                     | 4 | 1                | s | 50822786     |
| 122                  | 230    | 40                     | 4 | 1                | s | 50822787     |
| 137                  | 60     | 50                     | 4 | 1                | s | 50822790     |
| 137                  | 80     | 50                     | 4 | 1                | s | 50822791     |
| 137                  | 100    | 50                     | 4 | 1                | s | 50822792     |
| 137                  | 130    | 50                     | 4 | 1                | s | 50822793     |
| 137                  | 150    | 50                     | 4 | 1                | s | 50822794     |
| 137                  | 180    | 50                     | 4 | 1                | s | 50822795     |
| 137                  | 230    | 50                     | 4 | 1                | s | 50822798     |
| Toebehoren           |        | Afmeting [mm]          |   | VE [St.]         | V | Bestelnummer |
| Drukstuk             |        | B=40                   |   | 2                | o | 179221       |
| Drukstuk             |        | B=230                  |   | 2                | o | 179228       |
| Drukstuk             |        | B=180                  |   | 2                | o | 179227       |
| Drukstuk             |        | B=150                  |   | 2                | o | 179226       |
| Drukstuk             |        | B=130                  |   | 2                | o | 179225       |
| Drukstuk             |        | B=100                  |   | 2                | o | 179224       |
| Drukstuk             |        | B=80                   |   | 2                | o | 179223       |
| Drukstuk             |        | B=60                   |   | 2                | o | 179222       |
| Blindstukken         |        | B=40                   |   | 2                | o | 179229       |
| Blindstukken         |        | B=230                  |   | 2                | o | 179236       |
| Blindstukken         |        | B=180                  |   | 2                | o | 179235       |
| Blindstukken         |        | B=150                  |   | 2                | o | 179234       |
| Blindstukken         |        | B=130                  |   | 2                | o | 179233       |
| Blindstukken         |        | B=100                  |   | 2                | o | 179232       |
| Blindstukken         |        | B=80                   |   | 2                | o | 179231       |
| Blindstukken         |        | B=60                   |   | 2                | o | 179230       |
| Schroevendraaier     |        | SW5x150                |   | 1                |   | 168703       |
| Draadstift           |        | M10x20 DIN EN ISO 4028 |   | 10               |   | 815807       |

## Maximale buitendiameter

|                      | HS  | HW  | ST  | HS  | HW  | HS  | ST  |
|----------------------|-----|-----|-----|-----|-----|-----|-----|
| Meshoogte H [mm]     | 50  | 50  | 55  | 60  | 60  | 70  | 70  |
| Mesdikte S [mm]      | 8   | 10  | 10  | 8   | 10  | 8   | 10  |
| Profieldiepte T [mm] | 12  | 10  | 15  | 20  | 18  | 30  | 27  |
| Dmax bij D=122       | 161 | 161 | 171 | 181 | 181 | 201 | 201 |
| Dmax bij D=137       | 176 | 176 | 186 | 196 | 196 | 216 | 216 |

## Maximale toerental

|                          | 50   | 55   | 60   | 70   |  |  |  |
|--------------------------|------|------|------|------|--|--|--|
| Meshoogte H [mm]         |      |      |      |      |  |  |  |
| Dmax bij D=122           | 161  | 171  | 181  | 201  |  |  |  |
| Max. toerental (omw/min) | 9000 | 8400 | 8000 | 7200 |  |  |  |
|                          |      |      |      |      |  |  |  |
| Dmax bij D=137           | 176  | 186  | 196  | 216  |  |  |  |
| Max. toerental (omw/min) | 8200 | 7700 | 7300 | 6600 |  |  |  |

# HW 521-1 Hydro-profielschaafkoppen

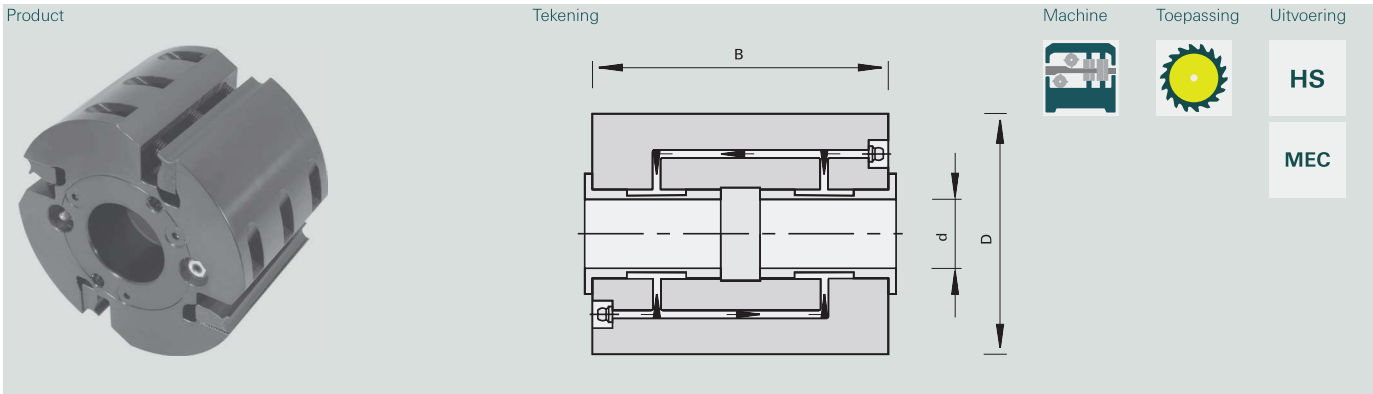

**Machine / gebruiksaanwijzing**

- Hydro-Profielfreesmachines
- Voor het profileren van massief hout

**Uitvoering**

- Body uit staal

**Voordelen**

- Hoge aanvoersnelheid bij uitstekende snijkwaliteit zonder tekening van mesaanzet
- Spelingvrije centrering door tweekamer-Hydro-opspanning, systeem Weinig
- Hoge rondloopprecisie en trillingsarme loop
- Spelingvrije mesbevestiging door zeer nauwkeurige vertanding 60 graden verdeling 1,6 mm

**Informatie - Tip**

- Messen nastelbaar
- Profieldiepte en buitendiameter zie tabel
- Voor blankets met rugvertanding met d = 8, 10mm
- Inhoud van de verpakking: schaafkop met drukstuk

**Producteigenschappen**

**Bestelinformatie**

| Ø D [mm] | B [mm] | Ø d [mm] | Z | VE [St.] | V | Bestelnummer |
|----------|--------|----------|---|----------|---|--------------|
| 137      | 60     | 40       | 4 | 1        | o | 58562920     |
| 137      | 100    | 40       | 4 | 1        | o | 58562921     |
| 137      | 130    | 40       | 4 | 1        | o | 58562922     |
| 137      | 150    | 40       | 4 | 1        | o | 58562923     |
| 137      | 180    | 40       | 4 | 1        | o | 58562924     |
| 137      | 230    | 40       | 4 | 1        | o | 58562925     |
| 150      | 60     | 50       | 4 | 1        | o | 58562926     |
| 150      | 60     | 50       | 6 | 1        | o | 58562934     |
| 150      | 100    | 50       | 4 | 1        | o | 58562927     |
| 150      | 100    | 50       | 6 | 1        | o | 58562935     |
| 150      | 130    | 50       | 4 | 1        | o | 58562928     |
| 150      | 130    | 50       | 6 | 1        | o | 58562936     |
| 150      | 150    | 50       | 4 | 1        | o | 58562929     |
| 150      | 150    | 50       | 6 | 1        | o | 58562937     |
| 150      | 180    | 50       | 4 | 1        | o | 58562930     |
| 150      | 180    | 50       | 6 | 1        | o | 58562938     |
| 150      | 230    | 50       | 4 | 1        | o | 58562931     |
| 150      | 230    | 50       | 6 | 1        | o | 58562939     |
| 150      | 260    | 50       | 4 | 1        | o | 58562932     |
| 150      | 260    | 50       | 6 | 1        | o | 58562940     |
| 150      | 310    | 50       | 4 | 1        | o | 58562933     |
| 150      | 310    | 50       | 6 | 1        | o | 58562941     |
| 163      | 60     | 50       | 8 | 1        | o | 58562942     |
| 163      | 100    | 50       | 8 | 1        | o | 58562943     |
| 163      | 130    | 50       | 8 | 1        | o | 58562944     |
| 163      | 150    | 50       | 8 | 1        | o | 58562945     |
| 163      | 180    | 50       | 8 | 1        | o | 58562946     |
| 163      | 230    | 50       | 8 | 1        | o | 58562947     |
| 163      | 260    | 50       | 8 | 1        | o | 58562948     |
| 163      | 310    | 50       | 8 | 1        | o | 58562949     |

**Toebehooren**

**Afmeting [mm]**

**VE [St.]**

**V Bestelnummer**

|                  |                        |    |        |
|------------------|------------------------|----|--------|
| Draadstift       | M12x25 DIN EN ISO 4028 | 10 | 181466 |
| Schroevendraaier | SW6x200                | 1  | 167817 |
| Vetspuiten       |                        | 1  | 163706 |
| Vetpatronen      |                        | 1  | 163707 |



## Maximale buitendiameter

|                      | HS  | HW  | ST  | HS  | HW  | HS  | ST  |
|----------------------|-----|-----|-----|-----|-----|-----|-----|
| Meshoogte H [mm]     | 50  | 50  | 55  | 60  | 60  | 70  | 70  |
| Mesdikte S [mm]      | 8   | 10  | 10  | 8   | 10  | 8   | 10  |
| Profieldiepte T [mm] | 12  | 10  | 15  | 20  | 18  | 30  | 27  |
| Dmax bij D=137       | 174 | 174 | 184 | 194 | 194 | 214 | 214 |
| Dmax bij D=150       | 189 | 189 | 199 | 209 | 209 | 229 | 229 |
| Dmax bij D=163       | 202 | 202 | 212 | 222 | 222 | 242 | 242 |

## Maximale toerental

|                          | 50   | 55   | 60   | 70   |  |  |  |
|--------------------------|------|------|------|------|--|--|--|
| Meshoogte H [mm]         | 50   | 55   | 60   | 70   |  |  |  |
| Dmax bij D=137           | 174  | 184  | 194  | 214  |  |  |  |
| Max. toerental (omw/min) | 8300 | 7800 | 7400 | 6700 |  |  |  |
| Dmax bij D=150           | 189  | 199  | 209  | 229  |  |  |  |
| Max. toerental (omw/min) | 7700 | 7300 | 6900 | 6300 |  |  |  |
| Dmax bij D=163           | 202  | 212  | 222  | 242  |  |  |  |
| Max. toerental (omw/min) | 7200 | 6800 | 6500 | 6000 |  |  |  |
| Dmax bij D=215           | 254  | 264  | 274  | 294  |  |  |  |
| Max. toerental (omw/min) | 5700 | 5400 | 5200 | 4900 |  |  |  |

# HS 525 Blankets met rugvertanding HS

Product



Tekening

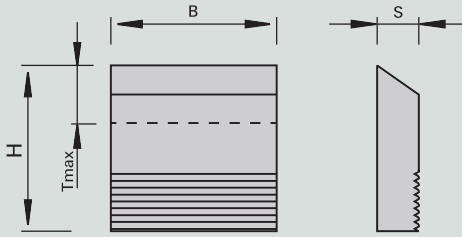

Machine



Toepassing



Uitvoering



**HS**



Machine / gebruiksaanwijzing

- Voor toepassing in rugvertande profiel-schaafkoppen

Uitvoering

- Snijmateriaal HS voor de bewerking van zacht hout

Voordelen

Informatie - Tip

- Tmax. = maximale profieldiepte
- Verpakkingseenheid 2 stuks

| Producteigenschappen |        |        |           | Bestelinformatie |   |              |
|----------------------|--------|--------|-----------|------------------|---|--------------|
| B [mm]               | H [mm] | S [mm] | Tmax [mm] | VE [St.]         | V | Bestelnummer |
| 40                   | 40     | 8.0    | -         | 2                | o | 50822701     |
| 40                   | 50     | 8.0    | 12        | 2                | o | 50822712     |
| 40                   | 60     | 8.0    | 20        | 2                |   | 50822713     |
| 40                   | 70     | 8.0    | 30        | 2                | o | 50822737     |
| 50                   | 40     | 8.0    | -         | 2                | o | 50822702     |
| 50                   | 50     | 8.0    | 12        | 2                | s | 50822711     |
| 60                   | 40     | 8.0    | 12        | 2                | o | 50822703     |
| 60                   | 50     | 8.0    | 20        | 2                | s | 50822714     |
| 60                   | 60     | 8.0    | 20        | 2                |   | 50822715     |
| 60                   | 70     | 8.0    | 30        | 2                | o | 50822738     |
| 80                   | 40     | 8.0    | -         | 2                | o | 50822704     |
| 80                   | 50     | 8.0    | 12        | 2                | o | 50822716     |
| 80                   | 60     | 8.0    | 20        | 2                | o | 50822717     |
| 80                   | 70     | 8.0    | 30        | 2                |   | 50822739     |
| 100                  | 40     | 8.0    | -         | 2                | o | 50822705     |
| 100                  | 50     | 8.0    | 12        | 2                | s | 50822718     |
| 100                  | 60     | 8.0    | 20        | 2                | s | 50822719     |
| 100                  | 70     | 8.0    | 30        | 2                | o | 50822740     |
| 130                  | 40     | 8.0    | -         | 2                | o | 50822706     |
| 130                  | 50     | 8.0    | 12        | 2                | s | 50822720     |
| 130                  | 60     | 8.0    | 20        | 2                | o | 50822721     |
| 130                  | 70     | 8.0    | 30        | 2                | s | 50822741     |
| 150                  | 40     | 8.0    | -         | 2                | o | 50822707     |
| 150                  | 50     | 8.0    | 12        | 2                | o | 50822722     |
| 150                  | 60     | 8.0    | 20        | 2                | o | 50822723     |
| 150                  | 70     | 8.0    | 30        | 2                | o | 50822742     |
| 180                  | 40     | 8.0    | -         | 2                | o | 50822708     |
| 180                  | 50     | 8.0    | 12        | 2                | s | 50822724     |
| 180                  | 60     | 8.0    | 20        | 2                | s | 50822725     |
| 180                  | 70     | 8.0    | 30        | 2                | o | 50822743     |
| 230                  | 40     | 8.0    | 12        | 2                |   | 50822709     |
| 230                  | 50     | 8.0    | 12        | 2                | o | 50822733     |
| 230                  | 60     | 8.0    | 20        | 2                | s | 50822735     |
| 230                  | 70     | 8.0    | 30        | 2                | o | 50822744     |
| 260                  | 40     | 8.0    | -         | 2                | o | 50822710     |
| 260                  | 50     | 8.0    | 12        | 2                | o | 50822734     |
| 260                  | 60     | 8.0    | 20        | 2                | o | 50822736     |
| 260                  | 70     | 8.0    | 30        | 2                | o | 50822745     |
| 650                  | 40     | 8.0    | -         | 2                | # | 50822751     |
| 650                  | 50     | 8.0    | 12        | 2                | s | 50822752     |
| 650                  | 60     | 8.0    | 20        | 2                |   | 50822753     |
| 650                  | 70     | 8.0    | 30        | 2                |   | 50822754     |

# HS 464 HS stokkenfreesen

Product



Tekening

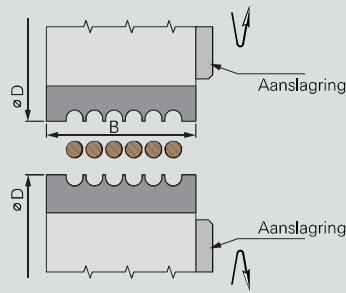

Machine



Toepassing



Uitvoering

HS

MEC

Machine / gebruiksaanwijzing

- Meer-assige freesautomaten
- Voor de productie van gladde ronde stokken van 2 tot 16 mm en van geribde pluggen van 6,1 tot 16,1 mm uit massief hout

Uitvoering

- Body uit staal
- Z=2 of Z=4 uitgevoerd

Voordelen

- Snel verwisselen van messen
- Zelfcenterende meszitting

Informatie - Tip

- Afstelplaat voor de mesinstelling in axiale richting
- Andere profielen op aanvraag

Producteigenschappen

Bestelinformatie

| Ø D [mm] | B [mm] | Ø d [mm] | Ø dmax [mm] | Z | nmax [min <sup>-1</sup> ] |  |  |  | VE [St.] | V | Bestelnummer |
|----------|--------|----------|-------------|---|---------------------------|--|--|--|----------|---|--------------|
| 102      | 50     | 35       | 40          | 2 | 6000                      |  |  |  | 1        | s | 50389261     |
| 102      | 75     | 35       | 40          | 2 | 6000                      |  |  |  | 1        | s | 50389262     |
| 102      | 100    | 35       | 40          | 2 | 6000                      |  |  |  | 1        | s | 50389263     |
| 102      | 50     | 40       | 40          | 2 | 6000                      |  |  |  | 1        | s | 50389264     |
| 102      | 75     | 40       | 40          | 2 | 6000                      |  |  |  | 1        | s | 50389265     |
| 102      | 100    | 40       | 40          | 2 | 6000                      |  |  |  | 1        | s | 50389266     |
| 102      | 125    | 40       | 40          | 2 | 6000                      |  |  |  | 1        | s | 50389267     |
| 102      | 150    | 40       | 40          | 2 | 6000                      |  |  |  | 1        | s | 50389268     |
| 102      | 50     | 35       | 40          | 4 | 6000                      |  |  |  | 1        | s | 50389269     |
| 102      | 75     | 35       | 40          | 4 | 6000                      |  |  |  | 1        | s | 50389270     |
| 102      | 100    | 35       | 40          | 4 | 6000                      |  |  |  | 1        | s | 50389271     |
| 102      | 50     | 40       | 40          | 4 | 6000                      |  |  |  | 1        | s | 50389272     |
| 102      | 75     | 40       | 40          | 4 | 6000                      |  |  |  | 1        | s | 50389273     |
| 102      | 100    | 40       | 40          | 4 | 6000                      |  |  |  | 1        | s | 50389274     |
| 102      | 125    | 40       | 40          | 4 | 6000                      |  |  |  | 1        | s | 50389275     |
| 102      | 150    | 40       | 40          | 4 | 6000                      |  |  |  | 1        | s | 50389276     |

Toebehoren

Afmeting [mm]

VE [St.]

V Bestelnummer

|                          |               |    |   |          |
|--------------------------|---------------|----|---|----------|
| Cilinderschroeven        | M8x30         | 10 | s | 180005   |
| Haakse schroevendraaiers | SW6x100       | 1  | o | 180383   |
| Onderlegingen            | B=8,4 DIN 125 | 10 | s | 50945505 |

# HS 464 HS segmenten voor gladde ronde stokken

Voor gladde ronde stokken

Product



Tekening

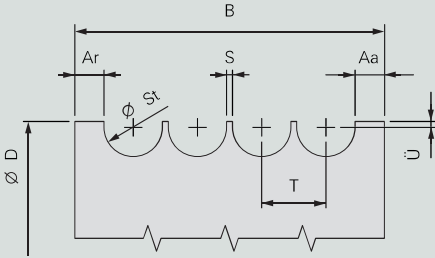

Machine



Toepassing



Uitvoering

1

**HS**

Machine / gebruiksaanwijzing

Uitvoering

Voordelen

Informatie - Tip

- Bij kleinere hoeveelheden + 50 % toeslag
- Tussenmaten + 25% toeslag op de volgende lagere maat
- Bij bestelling absoluut machinetype opgeven!
- Prijs per stuk bij gelijktijdige aankoop van 8 dezelfde messen

| MESSEN |                       |              |        |        |        |        |        |        |        |        |        |        |        |        |        |        |
|--------|-----------------------|--------------|--------|--------|--------|--------|--------|--------|--------|--------|--------|--------|--------|--------|--------|--------|
|        | St= staaf-Ø           | 2            | 3      | 4      | 5      | 6      | 7      | 8      | 9      | 10     | 11     | 12     | 13     | 14     | 15     | 16     |
|        | S= tussenstuk-breedte | 1            | 1      | 1      | 1      | 1      | 1      | 1      | 1      | 1,5    | 1,5    | 1,5    | 1,5    | 1,5    | 1,5    | 1,5    |
|        | T= verdeling          | 3            | 4      | 5      | 6      | 7      | 8      | 9      | 10     | 11     | 12,5   | 13,5   | 14,5   | 15,5   | 16,5   | 17,5   |
|        | D = diameter          | 127          | 127    | 127    | 127    | 127    | 127    | 135    | 135    | 135    | 135    | 135    | 135    | 135    | 135    | 135    |
| B=50   | Aantal staven         | 12           | 9      | 8      | 7      | 6      | 5      | 4      | 4      | 3      | 3      | 3      | 3      | 2      | 2      | 2      |
|        | Bestelnummer          | 50... 389200 | 389201 | 389202 | 389203 | 389204 | 389205 | 389206 | 389207 | 389208 | 389209 | 389210 | 389211 | 389212 | 389213 | 389214 |
| B=75   | Aantal staven         |              | 16     | 13     | 11     | 9      | 8      | 7      | 6      | 6      | 5      | 5      | 4      | 4      | 4      | 4      |
|        | Bestelnummer          | 50...        | 389215 | 389216 | 389217 | 389218 | 389219 | 389220 | 389221 | 389222 | 389223 | 389224 | 389225 | 389226 | 389227 | 389228 |
| B=100  | Aantal staven         |              |        | 18     | 15     | 13     | 11     | 10     | 9      | 8      | 7      | 6      | 6      | 6      | 5      | 5      |
|        | Bestelnummer          | 50...        |        | 389229 | 389230 | 389231 | 389232 | 389233 | 389234 | 389235 | 389236 | 389237 | 389238 | 389239 | 389240 | 389241 |
| B=125  | Aantal staven         |              |        |        | 16     | 14     | 13     | 11     | 10     | 9      | 8      | 8      | 7      | 7      | 7      |        |
|        | Bestelnummer          | 50...        |        |        | 389242 | 389243 | 389244 | 389245 | 389246 | 389247 | 389248 | 389249 | 389250 | 389251 | 389252 |        |
| B=150  | Aantal staven         |              |        |        |        |        |        | 14     | 13     | 11     | 10     | 9      | 9      | 8      | 8      |        |
|        | Bestelnummer          | 50...        |        |        |        |        |        | 389253 | 389254 | 389255 | 389256 | 389257 | 389258 | 389259 | 389260 |        |

# HS 464 HS segmenten voor geribde ronde stokken

Voor geribde ronde stokken

Product

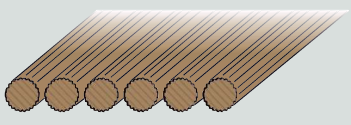

Tekening

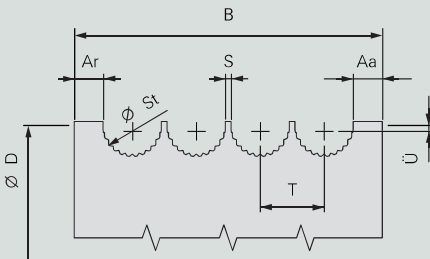

Machine

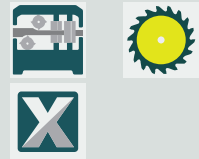

Toepassing



Uitvoering

1

**HS**

Machine / gebruiksaanwijzing

Uitvoering

Voordelen

Informatie - Tip

- Bij kleinere hoeveelheden + 50 % toeslag
- Tussenmaten + 25% toeslag op de volgende lagere maat
- Bij bestelling absoluut machinetype opgeven!
- Prijs per stuk bij gelijktijdige aankoop van 8 dezelfde messen

| MESSEN                |                    |        |        |        |        |        |        |        |        |        |        |
|-----------------------|--------------------|--------|--------|--------|--------|--------|--------|--------|--------|--------|--------|
| St= staaf-Ø           |                    | 6,1    | 7,1    | 8,1    | 10,1   | 11,1   | 12,1   | 13,1   | 14,1   | 15,1   | 16,1   |
| Aantal ribbels        |                    | 16     | 16     | 20     | 22     | 22     | 22     | 22     | 22     | 22     | 22     |
| S= tussenstuk-breedte |                    | 1      | 1      | 1      | 1      | 1,5    | 1,5    | 1,5    | 1,5    | 1,5    | 1,5    |
| T= verdeling          |                    | 7,1    | 8,1    | 9,1    | 11,1   | 12,6   | 13,6   | 14,6   | 15,6   | 16,6   | 17,6   |
| D = diameter          |                    | 127    | 127    | 135    | 135    | 135    | 135    | 135    | 135    | 135    | 135    |
| B=50                  | Aantal staven      | 6      | 5      | 4      | 3      | 3      | 3      | 3      | 2      | 2      | 2      |
|                       | Bestelnummer 50... | 389300 | 389301 | 389302 | 389303 | 389304 | 389305 | 389306 | 389307 | 389308 | 389309 |
| B=75                  | Aantal staven      | 9      | 8      | 7      | 6      | 5      | 5      | 4      | 4      | 4      | 3      |
|                       | Bestelnummer 50... | 389310 | 389311 | 389312 | 389313 | 389314 | 389315 | 389316 | 389317 | 389318 | 389319 |
| B=100                 | Aantal staven      | 12     | 11     | 10     | 8      | 7      | 6      | 6      | 5      | 5      | 5      |
|                       | Bestelnummer 50... | 389320 | 389321 | 389322 | 389323 | 389324 | 389325 | 389326 | 389327 | 389328 | 389329 |
| B=125                 | Aantal staven      | 16     | 14     | 13     | 10     | 9      | 8      | 8      | 7      | 7      | 6      |
|                       | Bestelnummer 50... | 389330 | 389331 | 389332 | 389333 | 389334 | 389335 | 389336 | 389337 | 389338 | 389339 |
| B=150                 | Aantal staven      |        |        |        | 12     | 11     | 10     | 9      | 9      | 8      | 8      |
|                       | Bestelnummer 50... |        |        |        | 389340 | 389341 | 389342 | 389343 | 389344 | 389345 | 389346 |

# HS 4000 Groef- en veergereedschappen

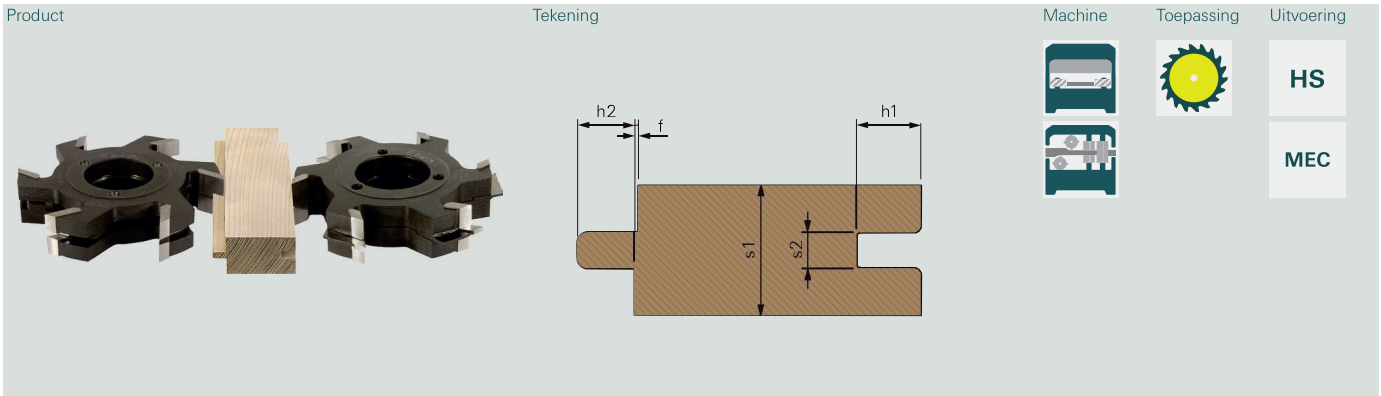

- |  |   |                         |  |
|--|---|-------------------------|--|
| <p><b>Machine / gebruiksaanwijzing</b></p> <ul style="list-style-type: none"> <li>• Tafelfreesmachine</li> <li>• Formaatbewerkingsmachines</li> <li>• Voor het maken van groef-/ en veerverbindingen, met en zonder onder strijken mbt. Fase in zacht en hardhout</li> </ul> | <p><b>Uitvoering</b></p> <ul style="list-style-type: none"> <li>• Body uit staal</li> <li>• Verstelbaar door tussenringen</li> <li>• Hoogste nauwkeurigheid doordat alle delen planparallel zijn</li> <li>• 3 meeneemgaten op steek 75 mm als verdraaiblokkering</li> </ul> | <p><b>Voordelen</b></p> | <p><b>Informatie - Tip</b></p> <ul style="list-style-type: none"> <li>• Bij bestelling draairichting, aanvoerrichting en zichtzijde volgens schema I, II, III of IV opgeven</li> <li>• Zonder bestelinformatie leveren we volgens schema I</li> <li>• Desgewenst tegen meerprijs ook leverbaar met HW-bezetting</li> </ul> |
|--|---|-------------------------|--|

| Producteigenschappen |          |        |          |                                       |                     |                     |        |     | Bestelinformatie |   |              |
|----------------------|----------|--------|----------|---------------------------------------|---------------------|---------------------|--------|-----|------------------|---|--------------|
| Profiel              | Ø D [mm] | B [mm] | Ø d [mm] | n <sub>max</sub> [min <sup>-1</sup> ] | s <sub>1</sub> [mm] | s <sub>2</sub> [mm] | f [mm] | Z   | VE [St.]         | V | Bestelnummer |
| 501/502              | 180      | 35     | 40       | 8000                                  | 12-36               | 4,5-7,5             | 0,5    | 6   | 1                | s | 58532354     |
| 505/506              | 180      | 35     | 40       | 8000                                  | 15-27               | 4,5-7,5             | 0,5    | 6   | 1                | s | 58532358     |
| 512/513              | 180      | 35     | 40       | 8000                                  | 12-27               | 4,5-7,5             |        | 6+3 | 1                | s | 58532361     |
| 503/502              | 180      | 35     | 40       | 8000                                  | 12-36               | 4,5-7,5             |        | 6   | 1                | s | 58532382     |
| 529/530              | 180      | 35     | 40       | 8000                                  | 15-27               | 4,5-7,5             | 0,5    | 6   | 1                | s | 58532384     |
| 507/508              | 180      | 35     | 40       | 8000                                  | 15-27               | 4,5-7,5             |        | 6   | 1                | s | 58532387     |
| 525/526              | 180      | 35     | 40       | 8000                                  | 12-27               | 4,5-7,5             |        | 6+3 | 1                | s | 58532390     |
| 541/540              | 180      | 35     | 40       | 8000                                  | 14-19               | 4,5-7,5             |        | 6+3 | 1                | s | 58532391     |

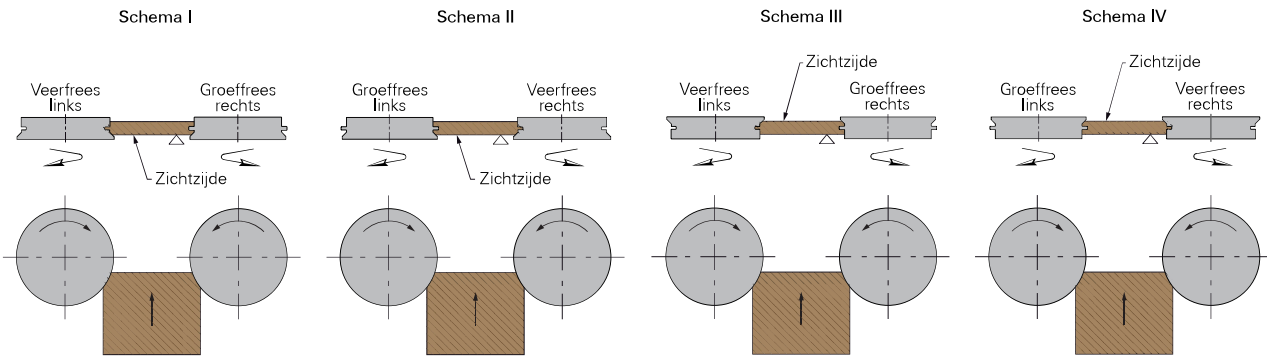

# 4000 Groef- en veergereedschappen

Weergave schema I

Veerfrees

Profiel 501

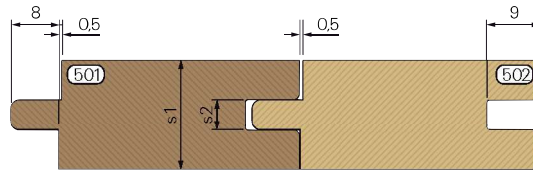

Groeffrees

Profiel 502

Profiel 503

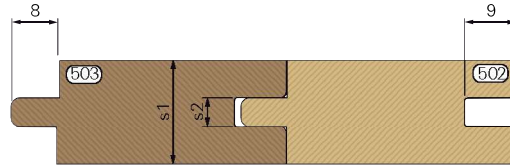

Profiel 502

Profiel 505

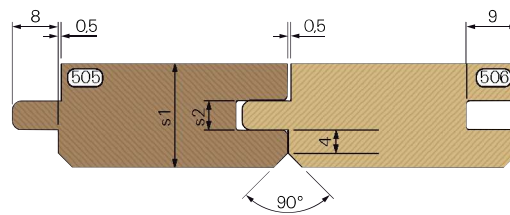

Profiel 506

Profiel 507

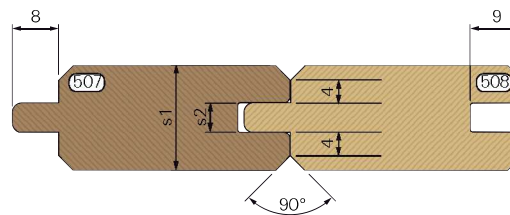

Profiel 508

Profiel 512

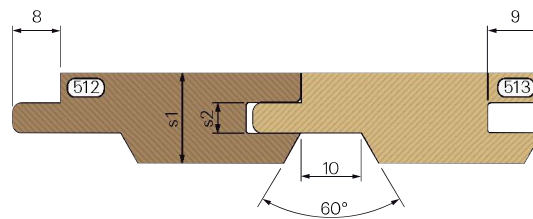

Profiel 513

Profiel 525

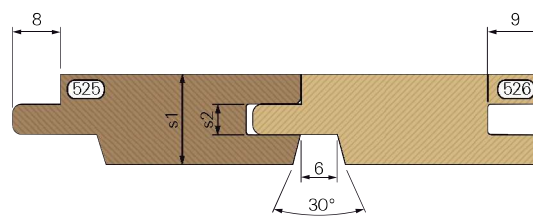

Profiel 526

Profiel 529

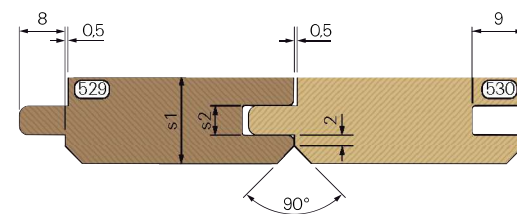



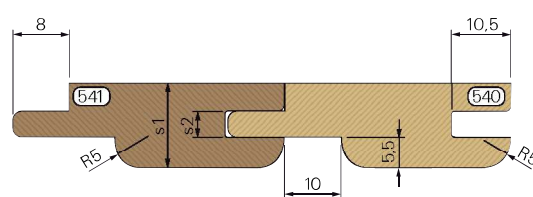

Profiel 530

Profiel 541

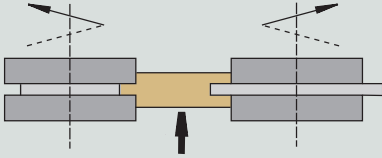

Profiel 540

## HW 4010 Groef- en veergereedschap HW - Silverline

|  |  |  |
|--|--|--|
| <p>Product</p>  | <p>Tekening</p>  | <p>Machine</p>   <p>Toepassing</p>  <p>Uitvoering</p> <p>MAN</p> <p>MEC</p> |
|--|--|--|

|  |  |   |                         |
|--|--|---|-------------------------|
| <p>Machine / gebruiksaanwijzing</p> <ul style="list-style-type: none"> <li>• Tafelfreesmachine</li> <li>• Formaatbewerkingsmachines</li> </ul> | <p>Uitvoering</p> <ul style="list-style-type: none"> <li>• Body van staal</li> <li>• Gemonteerd op een schroefbus</li> </ul> | <p>Voordelen</p> <ul style="list-style-type: none"> <li>• Uitstekende snijresultaten</li> <li>• Eenvoudig onderhoud</li> <li>• Bij vervangen van messen constante buitendiameter</li> </ul> | <p>Informatie - Tip</p> |
|--|--|---|-------------------------|

| Producteigenschappen |          |        |          |                          |   | Bestelinformatie      |          |     |              |
|----------------------|----------|--------|----------|--------------------------|---|-----------------------|----------|-----|--------------|
| Profiel              | Ø D [mm] | B [mm] | Ø d [mm] | n <sub>max</sub> [min-1] | Z | Freesnr.              | VE [St.] | V   | Bestelnummer |
| A                    | 140      | 13-33  | 30       | 8000                     | 2 | 1, 2, 3, 4, 5         | ☉        | 1 s | 68303301     |
| A                    | 140      | 13-33  | 40       | 8000                     | 2 | 1, 2, 3, 4, 5         | ☉        | 1 s | 68303401     |
| A                    | 140      | 13-33  | 50       | 8000                     | 2 | 1, 2, 3, 4, 5         | ☉        | 1 s | 68303501     |
| B                    | 140      | 13-33  | 30       | 8000                     | 2 | 1, 3, 4, 5, 6         | ☉        | 1 s | 68303302     |
| B                    | 140      | 13-33  | 40       | 8000                     | 2 | 1, 3, 4, 5, 6         | ☉        | 1 s | 68303402     |
| B                    | 140      | 13-33  | 50       | 8000                     | 2 | 1, 3, 4, 5, 6         | ☉        | 1 s | 68303502     |
| C                    | 140      | 13-40  | 30       | 8000                     | 2 | 1, 3, 4, 5, 6, 15, 16 | ☉        | 1 s | 68303303     |
| C                    | 140      | 13-40  | 40       | 8000                     | 2 | 1, 3, 4, 5, 6, 15, 16 | ☉        | 1 s | 68303403     |
| C                    | 140      | 13-40  | 50       | 8000                     | 2 | 1, 3, 4, 5, 6, 15, 16 | ☉        | 1 s | 68303503     |
| D                    | 140      | 13-36  | 30       | 8000                     | 2 | 1, 2, 3, 4, 5, 15, 16 | ☉        | 1 s | 68303304     |
| D                    | 140      | 13-36  | 40       | 8000                     | 2 | 1, 2, 3, 4, 5, 15, 16 | ☉        | 1 s | 68303404     |
| D                    | 140      | 13-36  | 50       | 8000                     | 2 | 1, 2, 3, 4, 5, 15, 16 | ☉        | 1 s | 68303504     |
| E                    | 140      | 13-36  | 30       | 8000                     | 2 | 1, 3, 4, 9, 10        | ☉        | 1 s | 68303305     |
| E                    | 140      | 13-36  | 40       | 8000                     | 2 | 1, 3, 4, 9, 10        | ☉        | 1 s | 68303405     |
| E                    | 140      | 13-36  | 50       | 8000                     | 2 | 1, 3, 4, 9, 10        | ☉        | 1 s | 68303505     |
| F                    | 140      | 13-36  | 30       | 8000                     | 2 | 1, 3, 4, 7, 8         | ☉        | 1 s | 68303306     |
| F                    | 140      | 13-36  | 40       | 8000                     | 2 | 1, 3, 4, 7, 8         | ☉        | 1 s | 68303406     |
| F                    | 140      | 13-36  | 50       | 8000                     | 2 | 1, 3, 4, 7, 8         | ☉        | 1 s | 68303506     |
| G                    | 140      | 13-36  | 30       | 8000                     | 2 | 3, 9, 11, 12, 14      | ☉        | 1 s | 68303307     |
| G                    | 140      | 13-36  | 40       | 8000                     | 2 | 3, 9, 11, 12, 14      | ☉        | 1 s | 68303407     |
| G                    | 140      | 13-36  | 50       | 8000                     | 2 | 3, 9, 11, 12, 14      | ☉        | 1 s | 68303507     |
| H                    | 140      | 13-36  | 30       | 8000                     | 2 | 3, 7, 11, 12, 13      | ☉        | 1 s | 68303308     |
| H                    | 140      | 13-36  | 40       | 8000                     | 2 | 3, 7, 11, 12, 13      | ☉        | 1 s | 68303408     |
| H                    | 140      | 13-36  | 50       | 8000                     | 2 | 3, 7, 11, 12, 13      | ☉        | 1 s | 68303508     |



| Producteigenschaften |          |        |               |              |   | Bestelinformatie      |  |          |   |              |
|----------------------|----------|--------|---------------|--------------|---|-----------------------|--|----------|---|--------------|
| Profiel              | Ø D [mm] | B [mm] | Ø d [mm]      | nmax [min-1] | Z | Freesnr.              |  | VE [St.] | V | Bestelnummer |
| A                    | 180      | 13-33  | 30            | 8000         | 4 | 1, 2, 3, 4, 5         |  | 1        | s | 68302301     |
| A                    | 180      | 13-33  | 40            | 8000         | 4 | 1, 2, 3, 4, 5         |  | 1        | s | 68302401     |
| A                    | 180      | 13-33  | 50            | 8000         | 4 | 1, 2, 3, 4, 5         |  | 1        | s | 68302501     |
| B                    | 180      | 13-33  | 30            | 8000         | 4 | 1, 3, 4, 5, 6         |  | 1        | s | 68302302     |
| B                    | 180      | 13-33  | 40            | 8000         | 4 | 1, 3, 4, 5, 6         |  | 1        | s | 68302402     |
| B                    | 180      | 13-33  | 50            | 8000         | 4 | 1, 3, 4, 5, 6         |  | 1        | s | 68302502     |
| C                    | 180      | 13-40  | 30            | 8000         | 4 | 1, 3, 4, 5, 6, 15, 16 |  | 1        | s | 68302303     |
| C                    | 180      | 13-40  | 40            | 8000         | 4 | 1, 3, 4, 5, 6, 15, 16 |  | 1        | s | 68302403     |
| C                    | 180      | 13-40  | 50            | 8000         | 4 | 1, 3, 4, 5, 6, 15, 16 |  | 1        | s | 68302503     |
| D                    | 180      | 13-36  | 30            | 8000         | 4 | 1, 2, 3, 4, 5, 15, 16 |  | 1        | s | 68302304     |
| D                    | 180      | 13-36  | 40            | 8000         | 4 | 1, 2, 3, 4, 5, 15, 16 |  | 1        | s | 68302404     |
| D                    | 180      | 13-36  | 50            | 8000         | 4 | 1, 2, 3, 4, 5, 15, 16 |  | 1        | s | 68302504     |
| E                    | 180      | 13-36  | 30            | 8000         | 4 | 1, 3, 4, 9, 10        |  | 1        | s | 68302305     |
| E                    | 180      | 13-36  | 40            | 8000         | 4 | 1, 3, 4, 9, 10        |  | 1        | s | 68302405     |
| E                    | 180      | 13-36  | 50            | 8000         | 4 | 1, 3, 4, 9, 10        |  | 1        | s | 68302505     |
| F                    | 180      | 13-36  | 30            | 8000         | 4 | 1, 3, 4, 7, 8         |  | 1        | s | 68302306     |
| F                    | 180      | 13-36  | 40            | 8000         | 4 | 1, 3, 4, 7, 8         |  | 1        | s | 68302406     |
| F                    | 180      | 13-36  | 50            | 8000         | 4 | 1, 3, 4, 7, 8         |  | 1        | s | 68302506     |
| G                    | 180      | 13-36  | 30            | 8000         | 4 | 3, 9, 11, 12, 14      |  | 1        | s | 68302307     |
| G                    | 180      | 13-36  | 40            | 8000         | 4 | 3, 9, 11, 12, 14      |  | 1        | s | 68302407     |
| G                    | 180      | 13-36  | 50            | 8000         | 4 | 3, 9, 11, 12, 14      |  | 1        | s | 68302507     |
| H                    | 180      | 13-36  | 30            | 8000         | 4 | 3, 7, 11, 12, 13      |  | 1        | s | 68302308     |
| H                    | 180      | 13-36  | 40            | 8000         | 4 | 3, 7, 11, 12, 13      |  | 1        | s | 68302408     |
| H                    | 180      | 13-36  | 50            | 8000         | 4 | 3, 7, 11, 12, 13      |  | 1        | s | 68302508     |
| Omkeermessen         |          |        | Afmeting [mm] |              |   |                       |  | VE [St.] | V | Bestelnummer |
| Fasemes              |          |        | 16x22x5,0     |              |   | Voor alle             |  | 10       |   | 183668       |
| Groefmes             |          |        | B=4           |              |   | Voor alle             |  | 2        | o | 68002122     |
| Omkeermessen         |          |        | 12x12x1,5     |              |   | Voor alle             |  | 10       |   | 50820012     |
| Omkeermessen         |          |        | 15x12x1,5     |              |   | Voor alle             |  | 10       |   | 50820015     |
| Omkeermessen         |          |        | 20x12x1,5     |              |   | Voor alle             |  | 10       |   | 50820020     |
| Voorsnijder          |          |        | 14x14x2       |              |   | Voor alle             |  | 10       |   | 50820014     |

# 4010 Groef- en veergereedschap HW - Silverline

Uitlevering volgens schema I

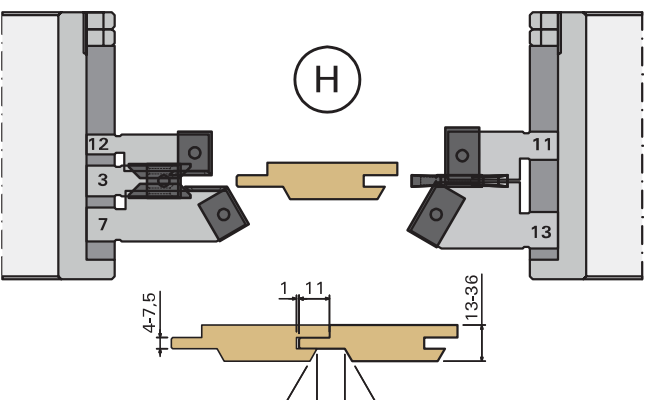
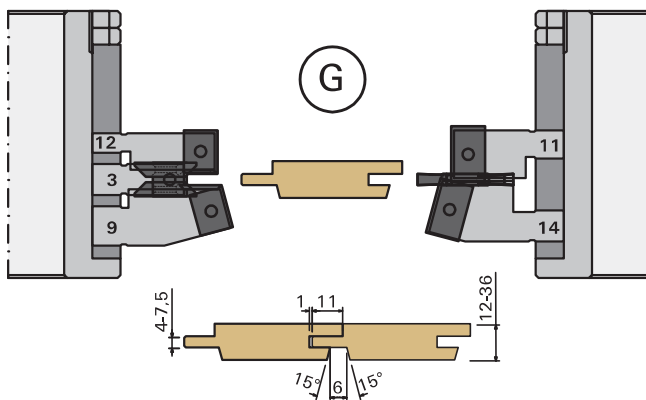
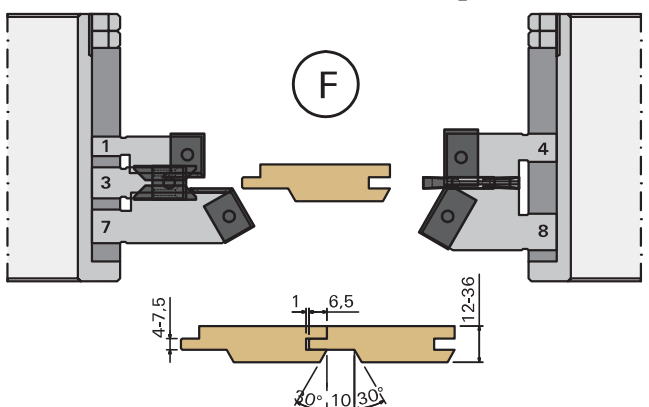
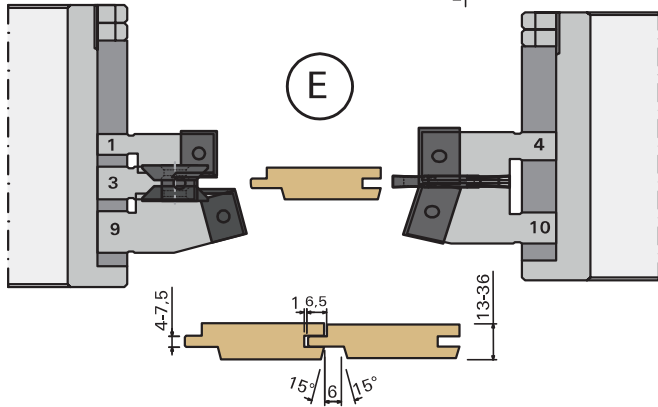
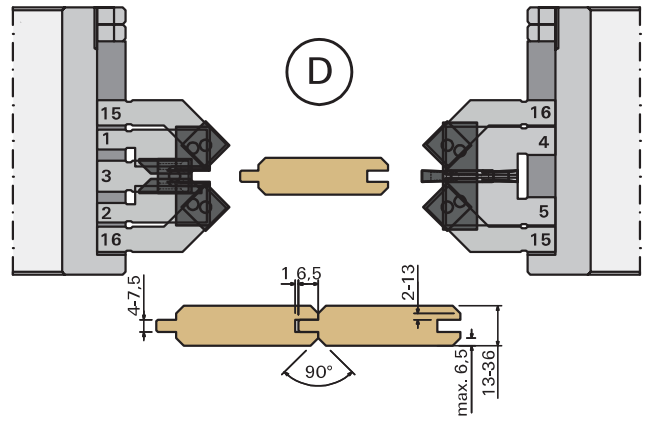
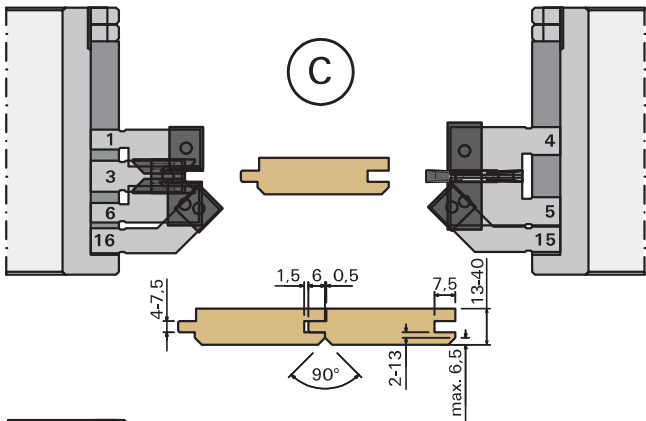
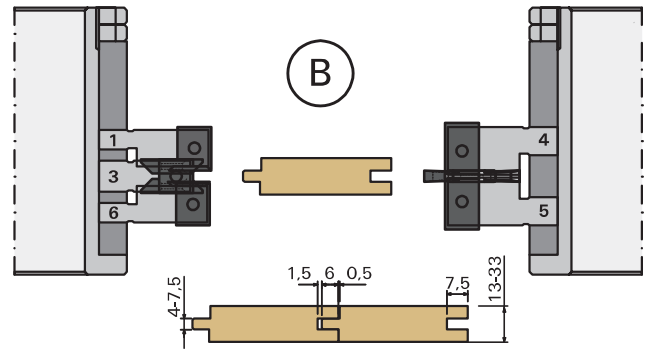
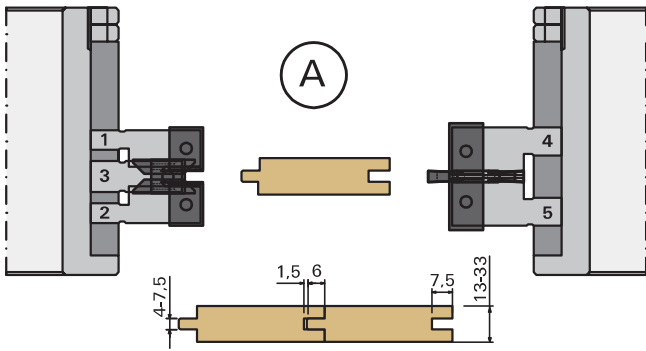

# CNC-FREESGEREED- SCHAP

## Inhoud

|                                       |      |
|---------------------------------------|------|
| HW-omkeermessen bovenfreesgereedschap | 3-1  |
| VHW-schrob/afwerkfrezen               | 3-6  |
| VHW-schrob/afwerkfrezen voor deuren   | 3-11 |
| DP-bovenfrees recht                   | 3-13 |
| Vlak-sponning bovenfrees              | 3-26 |
| Groef- en sponningfrezen              | 3-28 |
| Voeg-fase bovenfrees                  | 3-30 |
| Profiel-bovenfrees                    | 3-34 |

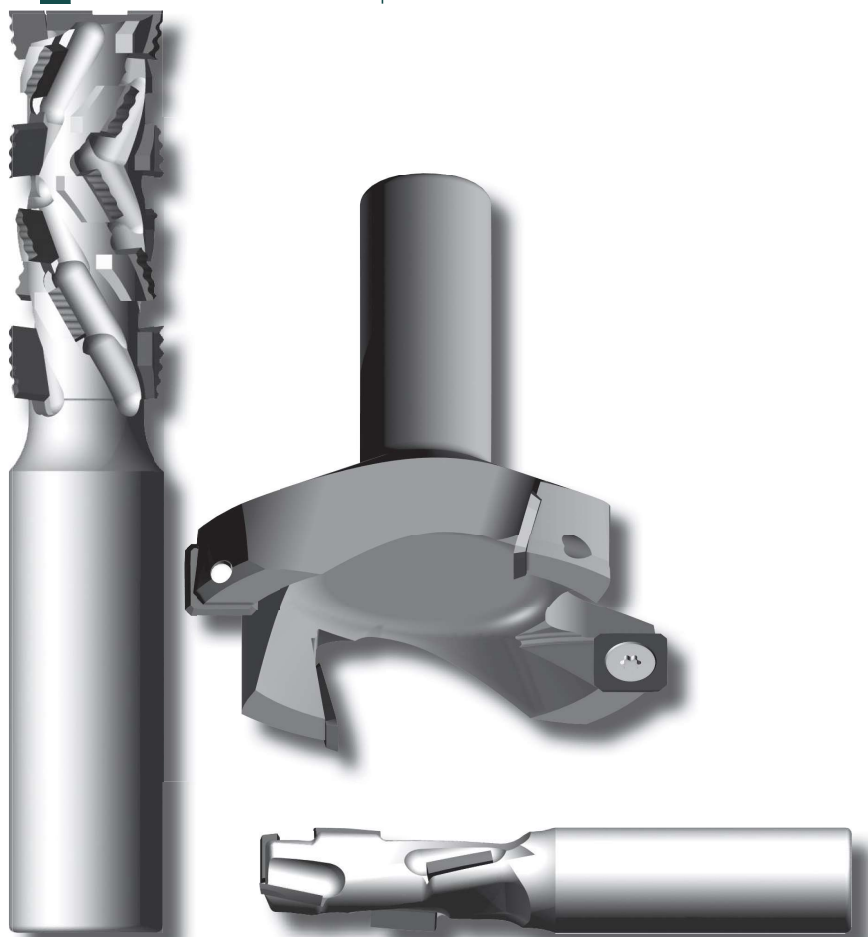

# HW 2231 Schachtfrees

Met HW-omkeermessen

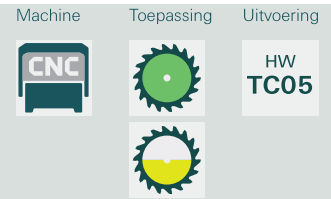
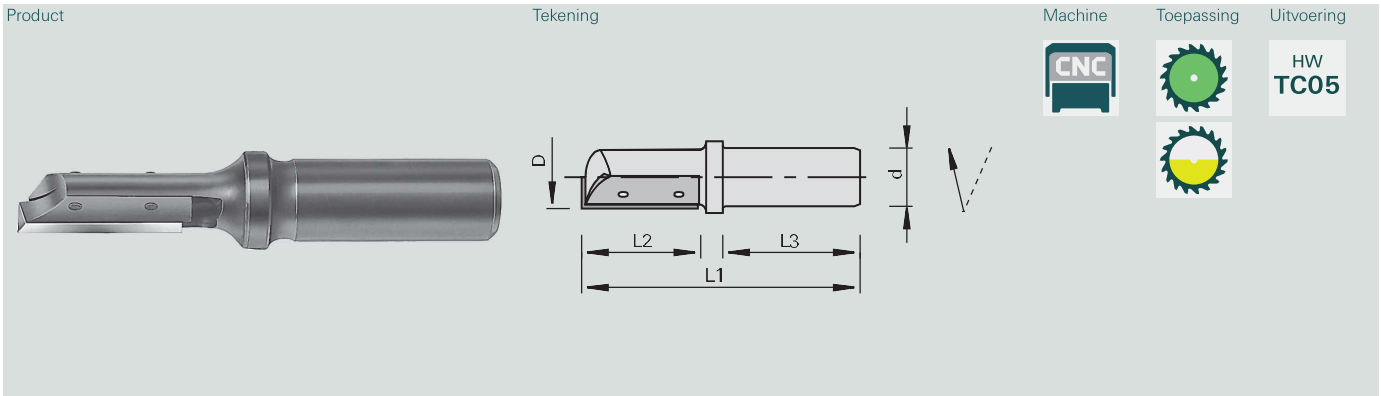

- |  |  |                         |  |
|--|--|-------------------------|--|
| <p><b>Machine / gebruiksaanwijzing</b></p> <ul style="list-style-type: none"> <li>• CNC-freesmachines</li> <li>• Voor het voegfrezen, sponningfrezen en groeffrezen in massief hout en plaatmateriaal op basis van hout</li> <li>• Voor het frezen van uitsparingen en contouren</li> <li>• Voor het inboren bij gelijktijdige aanzet in z-as en x- of y-as</li> </ul> | <p><b>Uitvoering</b></p> <ul style="list-style-type: none"> <li>• Snijkant asparallel en onder-snijdend</li> <li>• Tandbezetting: HW TC05</li> </ul> | <p><b>Voordelen</b></p> | <p><b>Informatie - Tip</b></p> <ul style="list-style-type: none"> <li>• Gereedschaphouder: ps-System, TRIBOS, spantangopspanning, adapter</li> </ul> |
|--|--|-------------------------|--|

| Producteigenschappen |         |               |         |                    | Bestelinformatie |        |        |               |          |              |              |
|----------------------|---------|---------------|---------|--------------------|------------------|--------|--------|---------------|----------|--------------|--------------|
| Ø D [mm]             | L2 [mm] | Ø d [mm]      | L1 [mm] | Z                  |                  |        |        | VE [St.]      | V        | Bestelnummer |              |
| 8.0                  | 20      | 12            | 70      | 1                  |                  |        |        | 1             |          | 50811001     |              |
| 10                   | 25      | 10            | 75      | 1                  |                  |        |        | 1             |          | 50811900     |              |
| 10                   | 25      | 12            | 75      | 1                  |                  |        |        | 1             |          | 50811002     |              |
| 12                   | 30      | 12            | 80      | 1                  |                  |        |        | 1             |          | 50811003     |              |
| Omkeermessen         |         |               |         |                    | B [mm]           | H [mm] | S [mm] | Snijmateriaal | VE [St.] | V            | Bestelnummer |
| Voor Ø D = 8         |         |               |         |                    | 20               | 4.1    | 1.1    | TC05          | 10       |              | 50450150     |
| Voor Ø D = 10        |         |               |         |                    | 25               | 5.5    | 1.1    | TC05          | 10       |              | 50450152     |
| Voor Ø D = 12+14     |         |               |         |                    | 30               | 5.5    | 1.1    | TC05          | 10       |              | 50450153     |
| Toebehoren           |         | Afmeting [mm] |         | Passend voor       |                  |        |        | VE [St.]      | V        | Bestelnummer |              |
| Drukstuk             |         | B=20          |         | 50811001           |                  |        |        | 2             | o        | 175722       |              |
| Drukstuk             |         | B=30          |         | 50811003           |                  |        |        | 2             | o        | 175726       |              |
| Drukstuk             |         | B=25          |         | 50811002, 50811900 |                  |        |        | 2             | o        | 175724       |              |
| Cilinderkopschroeven |         | M2,5x3 T8     |         | 50811001           |                  |        |        | 10            |          | 168237       |              |
| Cilinderkopschroeven |         | M3x5,5 T8     |         | 50811003           |                  |        |        | 10            |          | 168239       |              |
| Cilinderkopschroeven |         | M2,5x4 T8     |         | 50811002, 50811900 |                  |        |        | 10            |          | 168238       |              |
| Schroevendraaier     |         | T8            |         | Voor alle          |                  |        |        | 1             |          | 166499       |              |

# HW 2233 Schachtfrees Met HW-omkeermessen

Product

Tekening

Machine

Toepassing

Uitvoering

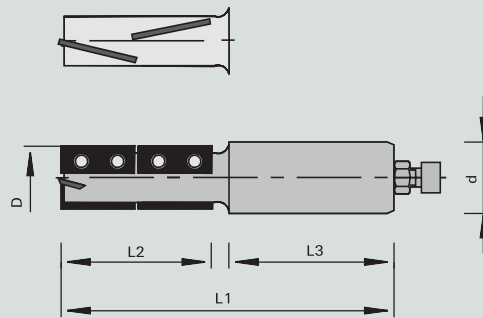

HW  
TC05

Machine / gebruiksaanwijzing

- CNC-freesmachines
- Voor het voegfreen, groeffreen, sponningfreen en kantenbewerken van beplakt plaatmateriaal op basis van hout en massief hout
- Voor het inboren bij gelijktijdige aanzet in z-as en x- of y-as

Uitvoering

- Verzet aangebrachte HW-omkeermessen met afwisselende ashoek
- Boorsnede: 4-zijdig HW omkeermes
- Tandbezetting: HW TC05

Voordelen

- 4x langere standtijd door omkeren en onderling verwisselen van de bovenste en onderste omkeermessen

Informatie - Tip

- Gereedschaphouder: ps-System, TRIBOS, spantangopspanning
- Met aanslagschroef

Producteigenschappen

Bestelinformatie

| Ø D [mm]         | L2 [mm] | Ø d [mm] | L3 [mm] | L1 [mm]       | Z   |        |        |        | VE [St.]      | V | Bestelnr. [L] | V | Bestelnr. [R] |
|------------------|---------|----------|---------|---------------|-----|--------|--------|--------|---------------|---|---------------|---|---------------|
| 20               | 53      | 25       | 55      | 125           | 2+2 |        |        |        | 1             | o | 50811901      |   | 50811902      |
| Omkeermessen     |         |          |         |               |     | B [mm] | H [mm] | S [mm] | Snijmateriaal |   | VE [St.]      | V | Bestelnummer  |
| Omkeermessen     |         |          |         |               |     | 29,5   | 7,0    | 1,5    | TC05          |   | 10            |   | 50825001      |
| Boorsnede        |         |          |         |               |     | 9      | 9,0    | 1,5    | TC05          |   | 10            |   | 50825003      |
| Toebehoren       |         |          |         | Afmeting [mm] |     |        |        |        |               |   | VE [St.]      | V | Bestelnummer  |
| Rondkopschroeven |         |          |         | M3x4 T9       |     |        |        |        |               |   | 10            |   | 180449        |
| Schroevendraaier |         |          |         | T9x60         |     |        |        |        |               |   | 1             |   | 173796        |

**HW**

## 2235 Schachtfrees

Met HW-omkeermessen

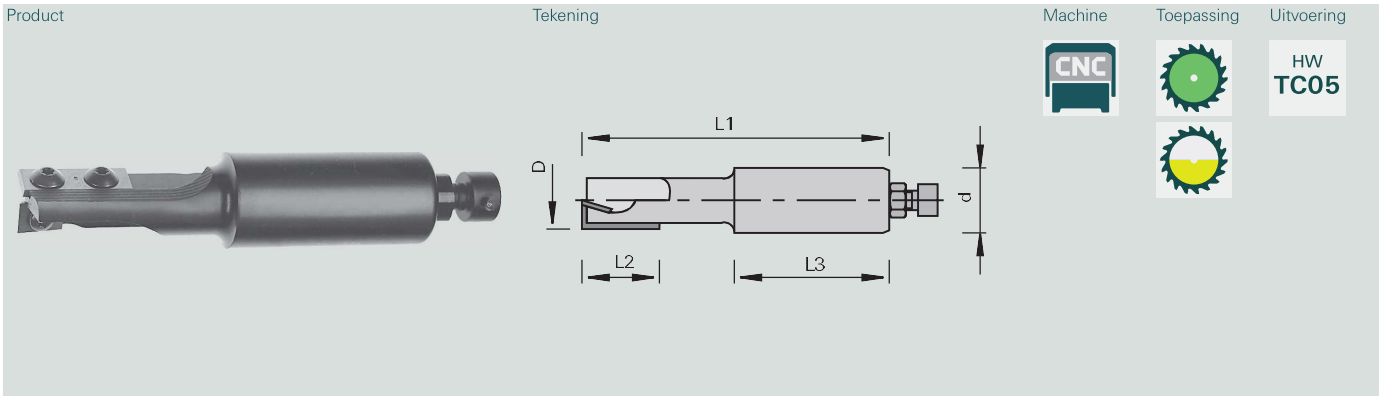

Machine



Toepassing



Uitvoering



Machine / gebruiksaanwijzing

- CNC-freesmachines
- Voor het voegfrezes, sponningfrezes en groeffrezes in massief hout en plaatmateriaal op basis van hout
- Voor het frezen van uitsparingen en contouren
- Voor het inboren bij gelijktijdige aanzet in z-as en x- of y-as

Uitvoering

- 1 snijkant asparallel omtrek-snijdend
- 1 snijkant voor het inboren met ashoek
- Tandbezetting: HW TC05

Voordelen

Informatie - Tip

- Gereedschaphouder: ps-System met reduceerhulzen, TRIBOS, spantangopname
- Met aanslagschroef

Producteigenschappen

Bestelinformatie

| Ø D [mm]             | L2 [mm] | Ø d [mm] | L3 [mm]       | L1 [mm] | Z   |        |        |        | VE [St.]      | V        | Bestelnummer |              |
|----------------------|---------|----------|---------------|---------|-----|--------|--------|--------|---------------|----------|--------------|--------------|
| 16                   | 30      | 16       | 43            | 92      | 1+1 |        |        |        | 1             |          | 50811903     |              |
| Omkeermessen         |         |          |               |         |     | B [mm] | H [mm] | S [mm] | Snijmateriaal | VE [St.] | V            | Bestelnummer |
| Boorsnede voor Ø 16  |         |          |               |         |     | 7,5    | 12     | 1,5    | TC05          | 10       |              | 50820007     |
| Omkeermessen         |         |          |               |         |     | 29,5   | 12     | 1,5    | TC05          | 10       | s            | 50825004     |
| Toebehoren           |         |          | Afmeting [mm] |         |     |        |        |        | VE [St.]      | V        | Bestelnummer |              |
| Cilinderkopschroeven |         |          | M3,5x3,8 T15  |         |     |        |        |        | 10            |          | 162645       |              |
| Rondkopschroeven     |         |          | M3,5x4 T15    |         |     |        |        |        | 10            |          | 168893       |              |
| Schroevendraaier     |         |          | T15           |         |     |        |        |        | 1             |          | 163161       |              |

# HW 2236 Schachtfrees Met HW-omkeermessen

Product

Tekening

Machine

Toepassing

Uitvoering

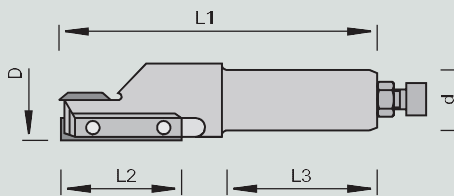

HW  
TC05

Machine / gebruiksaanwijzing

- CNC-freesmachines
- Voor het voegfrezen, sponningfrezen en groeffrezen in massief hout en plaatmateriaal op basis van hout
- Voor het frezen van uitsparingen en contouren
- Voor het inboren bij gelijktijdige aanzet in z-as en x- of y-as

Uitvoering

- 1 snijkant asparallel omtrek-snijdend
- 1 snijkant voor het inboren
- Tandbezetting: HW TC05
- Met aanslagschroef

Voordelen

Informatie - Tip

- Gereedschapouder: ps-System met reduceerhulzen, TRIBOS, spantangopname, adapter
- Met aanslagschroef

Producteigenschappen

Bestelinformatie

| Ø D [mm] | L2 [mm] | Ø d [mm] | L3 [mm] | L1 [mm] | Z   | VE [St.] | V | Bestelnr. [L] | V | Bestelnr. [R] |
|----------|---------|----------|---------|---------|-----|----------|---|---------------|---|---------------|
| 16       | 50      | 16       | 45      | 106     | 1+1 | 1        |   |               |   | 50811904      |
| 16       | 50      | 25       | 55      | 116     | 1+1 | 1        |   |               |   | 50811905      |
| 18       | 50      | 25       | 55      | 116     | 1+1 | 1        |   | 50811906      |   | 50811907      |

| Omkeermessen      | B [mm] | H [mm] | S [mm] | Snijmateriaal | VE [St.] | V | Bestelnummer |
|-------------------|--------|--------|--------|---------------|----------|---|--------------|
| Omkeermessen      | 12     | 12     | 1.5    | TC05          | 10       |   | 50820012     |
| Mini-omkeermessen | 50     | 5.5    | 1.1    | TC05          | 10       |   | 50450155     |

| Toebehoren           | Afmeting [mm] | Passend voor       | VE [St.] | V | Bestelnummer |
|----------------------|---------------|--------------------|----------|---|--------------|
| Drukstuk             | B=50          | 50811904, 50811905 | 2        | o | 171111       |
| Drukstuk             | B=50          | 50811906           | 2        | o | 171114       |
| Drukstuk             | B=50          | 50811907           | 2        | o | 171113       |
| Cilinderkopschroeven | M3,5x5,5 T15  | Voor alle          | 10       |   | 168236       |
| Rondkopschroeven     | M4x5,9 T15    | Voor alle          | 10       |   | 167966       |
| Schroevendraaier     | T15           | Voor alle          | 1        |   | 163161       |

**HW**

**2237 Schachtfrees**

Met HW-omkeermessen

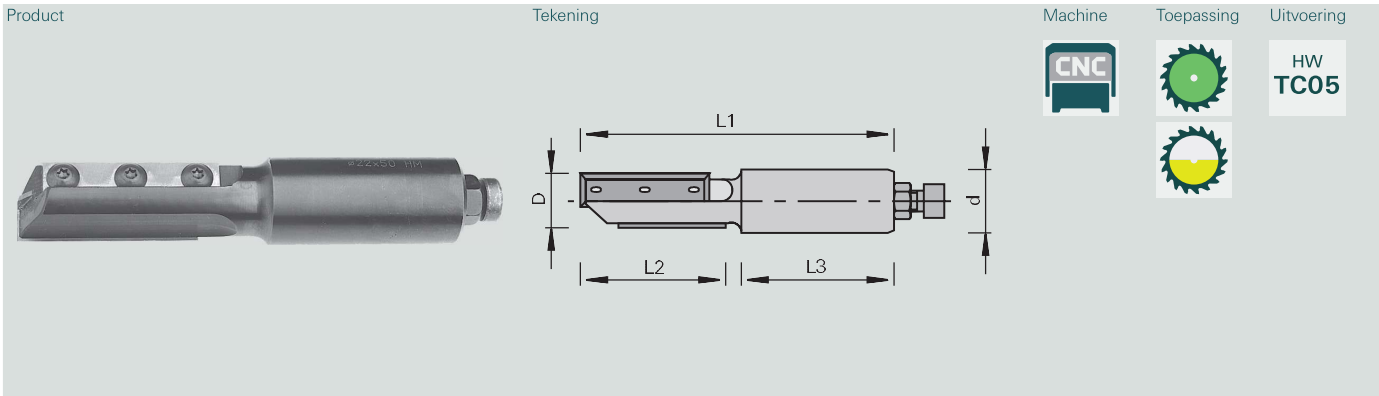

| Machine / gebruiksaanwijzing  | Uitvoering   | Voordelen | Informatie - Tip  |
|---|--|-----------|---|
| <ul style="list-style-type: none"> <li>• CNC-freesmachines</li> <li>• Voor het voegfrezes, sponningfrezes en groeffrezes in massief hout en plaatmateriaal op basis van hout</li> <li>• Voor het frezen van uitsparingen en contouren</li> <li>• Voor het inboren bij gelijktijdige aanzet in z-as en x- of y-as</li> </ul> | <ul style="list-style-type: none"> <li>• Snijkanten asparallel omtrek-snijdend in verzet patroon</li> <li>• 1 snijkant voor het inboren</li> <li>• Tandbezetting: HW TC05</li> <li>• Met aanslagschroef</li> </ul> |           | <ul style="list-style-type: none"> <li>• Gereedschaphouder: ps-System met reduceerhulzen, TRIBOS, spantangopname</li> <li>• Met aanslagschroef</li> </ul> |

| Producteigenschappen |         |          |         |               |        | Bestelinformatie |               |  |          |          |               |              |               |
|----------------------|---------|----------|---------|---------------|--------|------------------|---------------|--|----------|----------|---------------|--------------|---------------|
| Ø D [mm]             | L2 [mm] | Ø d [mm] | L3 [mm] | L1 [mm]       | Z      |                  |               |  | VE [St.] | V        | Bestelnr. [L] | V            | Bestelnr. [R] |
| 18                   | 55      | 25       | 55      | 125           | 2      |                  |               |  | 1        |          | 50811909      |              | 50811908      |
| 20                   | 55      | 25       | 55      | 125           | 2      |                  |               |  | 1        |          |               |              | 50811910      |
| Omkeermessen         |         |          |         | B [mm]        | H [mm] | S [mm]           | Snijmateriaal |  |          |          | VE [St.]      | V            | Bestelnummer  |
| Omkeermessen         |         |          |         | 50            | 12     | 1.7              | TC05          |  |          |          | 10            |              | 50450121      |
| Toebehoren           |         |          |         | Afmeting [mm] |        |                  |               |  |          | VE [St.] | V             | Bestelnummer |               |
| Schroevendraaier     |         |          |         | T15           |        |                  |               |  |          | 1        |               | 163161       |               |
| Rondkopschroeven     |         |          |         | M4x5,9 T15    |        |                  |               |  |          | 10       |               | 167966       |               |



# VHW 2265 Schrobrees

Met negatieve spiraal

Product

Tekening

Machine

Toepassing

Uitvoering

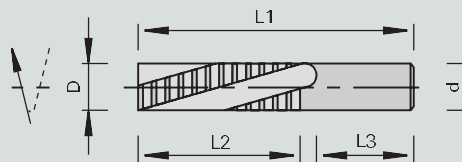
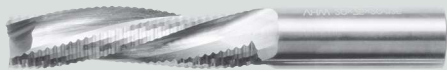

Machine / gebruiksaanwijzing

- CNC-freesmachines
- Voor ruwfreen van massief hout en multiplex en van niet-bekleed plaatmateriaal op basis van hout
- Voor het frezen van uitsparingen en contouren
- Voor het inboren bij gelijktijdige aanzet in z-as en x- of y-as

Uitvoering

- Negatieve spiraal voor kleinere en moeilijk op te spannen werkstukken met de zichtkant boven
- n-max = 30.000 (omw/min)

Voordelen

- Hoog verspanend vermogen
- Snijdruk naar onderen door negatieve spiraal

Informatie - Tip

- Snijvlak licht golvend door fijne snedeverdeling
- Gereedschaphouder: ps-System met reduceerhulzen, TRIBOS, spantangopname

Producteigenschappen

Bestelinformatie

| Ø D [mm] | L2 [mm] | Ø d [mm] | L3 [mm] | L1 [mm] | Z |  |  |  |  | VE [St.] | V | Bestelnummer |
|----------|---------|----------|---------|---------|---|--|--|--|--|----------|---|--------------|
| 10       | 30      | 10       | 40      | 75      | 2 |  |  |  |  | 1        | s | 50811402     |
| 12       | 42      | 12       | 45      | 90      | 3 |  |  |  |  | 1        | # | 50811404     |
| 16       | 35      | 16       | 48      | 90      | 3 |  |  |  |  | 1        |   | 50811029     |
| 16       | 55      | 16       | 48      | 110     | 3 |  |  |  |  | 1        |   | 50811409     |
| 20       | 55      | 20       | 50      | 115     | 3 |  |  |  |  | 1        |   | 50811414     |

# VHW 2265-1 Schrobrees

Met positieve spiraal

Product

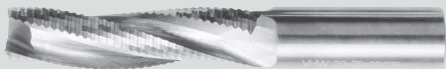

Tekening

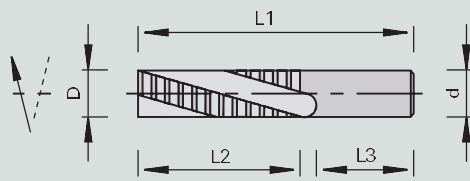

Machine



Toepassing



Uitvoering



|   |  |  |   |
|---|--|--|---|
| <p>Machine / gebruiksaanwijzing</p> <ul style="list-style-type: none"> <li>• CNC-freesmachines</li> <li>• Voor ruwfreesen van massief hout en multiplex en van niet-bekleed plaatmateriaal op basis van hout</li> <li>• Voor het frezen van uitsparingen en contouren</li> <li>• Voor het inboren bij gelijktijdige aanzet in z-as en x- of y-as</li> </ul> | <p>Uitvoering</p> <ul style="list-style-type: none"> <li>• Positieve spiraal voor goed opgespannen werkstukken met de zichtkant onder</li> <li>• n-max = 30.000 (omw/min)</li> </ul> | <p>Voordelen</p> <ul style="list-style-type: none"> <li>• Hoog verspanend vermogen</li> <li>• Optimale spaanuitworp naar boven door positieve spiraal</li> </ul> | <p>Informatie - Tip</p> <ul style="list-style-type: none"> <li>• Snijvlak licht golvend door fijne snedeverdeling</li> <li>• Gereedschaphouder: ps-System met reduceerhulzen, TRIBOS, spantangopname</li> </ul> |
|---|--|--|---|

| Producteigenschappen |         |          |         |         |   | Bestelinformatie |  |          |   |              |
|----------------------|---------|----------|---------|---------|---|------------------|--|----------|---|--------------|
| Ø D [mm]             | L2 [mm] | Ø d [mm] | L3 [mm] | L1 [mm] | Z |                  |  | VE [St.] | V | Bestelnummer |
| 10                   | 30      | 10       | 40      | 75      | 2 |                  |  | 1        |   | 50811401     |
| 12                   | 45      | 12       | 45      | 90      | 2 |                  |  | 1        |   | 50811403     |
| 12                   | 45      | 12       | 45      | 90      | 3 |                  |  | 1        |   | 50811025     |
| 14                   | 35      | 14       | 45      | 90      | 3 |                  |  | 1        |   | 50811026     |
| 14                   | 55      | 14       | 45      | 110     | 3 |                  |  | 1        |   | 50811027     |
| 16                   | 35      | 16       | 48      | 90      | 2 |                  |  | 1        |   | 50811407     |
| 16                   | 35      | 16       | 48      | 90      | 3 |                  |  | 1        |   | 50811028     |
| 16                   | 55      | 16       | 48      | 110     | 2 |                  |  | 1        |   | 50811410     |
| 16                   | 55      | 16       | 48      | 110     | 3 |                  |  | 1        |   | 50811408     |
| 18                   | 55      | 18       | 48      | 115     | 3 |                  |  | 1        |   | 50811030     |
| 20                   | 55      | 20       | 50      | 115     | 2 |                  |  | 1        |   | 50811413     |
| 20                   | 55      | 20       | 50      | 115     | 3 |                  |  | 1        |   | 50811031     |
| 20                   | 75      | 20       | 50      | 135     | 3 |                  |  | 1        |   | 50811032     |

# VHW 2257 Afwerkrees

Met negatieve spiraal

Product

Tekening

Machine

Toepassing

Uitvoering

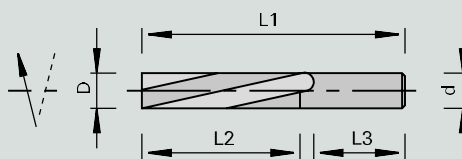

Machine / gebruiksaanwijzing

- CNC-freesmachines
- Voor het nabewerken van massief hout en kunststoffen
- Voor het frezen van uitsparingen en contouren
- Voor het inboren bij gelijktijdige aanzet in z-as en x- of y-as

Uitvoering

- Negatieve spiraal voor kleinere en moeilijk op te spannen werkstukken met de zichtkant boven
- n-max = 30.000 (omw/min)

Voordelen

- Snijdruk en optimale spaan-uitworp naar onderen door negatieve spiraal

Informatie - Tip

- Gereedschaphouder: ps-System met reduceerhulzen, TRIBOS, spantangopname

Producteigenschappen

Bestelinformatie

| Ø D [mm] | L2 [mm] | Ø d [mm] | L3 [mm] | L1 [mm] | Z |  |  |  |  | VE [St.] | V | Bestelnummer |
|----------|---------|----------|---------|---------|---|--|--|--|--|----------|---|--------------|
| 4.0      | 15      | 4,0      | 28      | 60      | 2 |  |  |  |  | 1        |   | 50811418     |
| 6.0      | 15      | 6,0      | 36      | 60      | 2 |  |  |  |  | 1        |   | 50811420     |
| 8.0      | 30      | 8,0      | 36      | 75      | 2 |  |  |  |  | 1        |   | 50811421     |
| 10       | 30      | 10       | 40      | 75      | 2 |  |  |  |  | 1        |   | 50811422     |
| 12       | 42      | 12       | 45      | 90      | 2 |  |  |  |  | 1        |   | 50811423     |
| 12       | 42      | 12       | 45      | 90      | 3 |  |  |  |  | 1        |   | 50811425     |
| 16       | 35      | 16       | 48      | 90      | 2 |  |  |  |  | 1        |   | 50811428     |
| 16       | 35      | 16       | 48      | 90      | 3 |  |  |  |  | 1        |   | 50811430     |
| 16       | 55      | 16       | 48      | 110     | 3 |  |  |  |  | 1        |   | 50811435     |
| 20       | 55      | 20       | 50      | 115     | 3 |  |  |  |  | 1        | o | 50811438     |
| 20       | 75      | 20       | 50      | 135     | 3 |  |  |  |  | 1        |   | 50811562     |

# VHW 2257-1 Afwerkrees

Met positieve spiraal

Product



Tekening

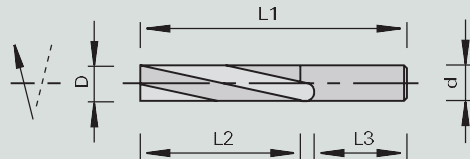



Machine



Toepassing



Uitvoering

|   |  |  |   |
|---|--|--|---|
| <p>Machine / gebruiksaanwijzing</p> <ul style="list-style-type: none"> <li>• CNC-freesmachines</li> <li>• Voor het nabewerken van massief hout en kunststoffen</li> <li>• Voor het frezen van uitsparingen en contouren</li> <li>• Voor het inboren bij gelijktijdige aanzet in z-as en x- of y-as</li> </ul> | <p>Uitvoering</p> <ul style="list-style-type: none"> <li>• Positieve spiraal voor goed opgespannen werkstukken met de zichtkant onder</li> <li>• n-max = 30.000 (omw/min)</li> </ul> | <p>Voordelen</p> <ul style="list-style-type: none"> <li>• Optimale spaanuitworp naar boven door positieve spiraal</li> </ul> | <p>Informatie - Tip</p> <ul style="list-style-type: none"> <li>• Gereedschaphouder: ps-System met reduceerhulzen, TRIBOS, spantangopname</li> </ul> |
|---|--|--|---|

| Producteigenschappen |         |          |         |         |   | Bestelinformatie |  |  |          |   |               |   |               |
|----------------------|---------|----------|---------|---------|---|------------------|--|--|----------|---|---------------|---|---------------|
| Ø D [mm]             | L2 [mm] | Ø d [mm] | L3 [mm] | L1 [mm] | Z |                  |  |  | VE [St.] | V | Bestelnr. [L] | V | Bestelnr. [R] |
| 6.0                  | 15      | 6,0      | 36      | 60      | 2 |                  |  |  | 1        |   |               |   | 50811419      |
| 8.0                  | 30      | 8,0      | 36      | 75      | 2 |                  |  |  | 1        |   |               |   | 50811034      |
| 10                   | 30      | 10       | 40      | 75      | 2 |                  |  |  | 1        |   |               |   | 50811036      |
| 12                   | 42      | 12       | 45      | 90      | 2 |                  |  |  | 1        |   |               |   | 50811037      |
| 12                   | 42      | 12       | 45      | 90      | 3 |                  |  |  | 1        |   |               |   | 50811424      |
| 14                   | 35      | 14       | 45      | 90      | 3 |                  |  |  | 1        |   |               |   | 50811426      |
| 14                   | 55      | 14       | 45      | 110     | 3 |                  |  |  | 1        |   |               |   | 50811427      |
| 16                   | 35      | 16       | 48      | 90      | 2 |                  |  |  | 1        |   |               |   | 50811040      |
| 16                   | 35      | 16       | 48      | 90      | 3 |                  |  |  | 1        |   |               |   | 50811429      |
| 16                   | 55      | 16       | 48      | 110     | 2 |                  |  |  | 1        |   |               |   | 50811041      |
| 16                   | 55      | 16       | 48      | 110     | 3 |                  |  |  | 1        |   | 50811434      |   | 50811432      |
| 18                   | 55      | 18       | 48      | 115     | 3 |                  |  |  | 1        |   |               |   | 50811436      |
| 20                   | 55      | 20       | 50      | 115     | 3 |                  |  |  | 1        |   |               |   | 50811437      |
| 20                   | 75      | 20       | 50      | 135     | 3 |                  |  |  | 1        |   |               |   | 50811439      |

# VHW 2257-2 Afwerkfrees

Met DUAL spiraal

Product

Tekening

Machine

Toepassing

Uitvoering

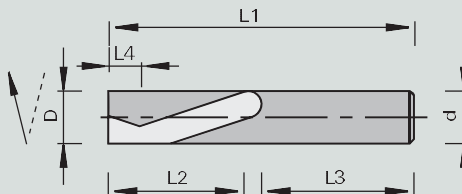

Machine / gebruiksaanwijzing

- CNC-freesmachines
- Voor het nabewerken van massief hout en kunststoffen
- Voor het frezen van uitsparingen en contouren
- Voor het inboren bij gelijktijdige aanzet in z-as en x- of y-as

Uitvoering

- Met DUAL spiraal
- n-max = 30.000 (omw/min)

Voordelen

- Uitstekende snijkwaliteit bij beplakt plaatmateriaal op basis van hout door DUAL spiraal

Informatie - Tip

- Gereedschaphouder: ps-System met reduceerhulzen, TRIBOS, spantangopname





Producteigenschappen

Bestelinformatie

| Ø D [mm] | L4 [mm] | L2 [mm] | Ø d [mm] | L1 [mm] | Z   |  |  |  |  | VE [St.] | V | Bestelnummer |
|----------|---------|---------|----------|---------|-----|--|--|--|--|----------|---|--------------|
| 8.0      | 7.0     | 32      | 8.0      | 80      | 2+2 |  |  |  |  | 1        |   | 50811564     |
| 10       | 7.0     | 32      | 10       | 80      | 2+2 |  |  |  |  | 1        |   | 50811565     |
| 12       | 7.0     | 42      | 12       | 90      | 2+2 |  |  |  |  | 1        |   | 50811566     |
| 16       | 24      | 55      | 16       | 110     | 2+2 |  |  |  |  | 1        |   | 50811567     |

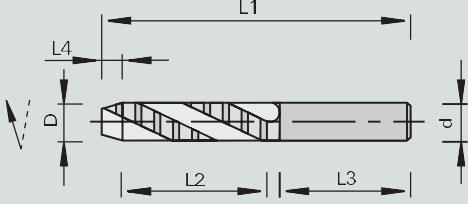
## VHW 2268 Ventilatie schrobrees

Voor de productie van deuren





|   |  |   |   |   |
|---|--|---|---|---|
| Product   | Tekening   | Machine   | Toepassing  | Uitvoering  |
|  |  |  |  |  |

|  |   |           |  |
|--|---|-----------|--|
| Machine / gebruiksaanwijzing   | Uitvoering  | Voordelen | Informatie - Tip   |
| <ul style="list-style-type: none"> <li>• CNC-bewerkingscentra</li> <li>• Voor het maken van deurklinkgaten en cilinderslotgaten</li> </ul> | <ul style="list-style-type: none"> <li>• Positieve spiraal</li> <li>• n max = 30.000 min-1</li> </ul> |           | <ul style="list-style-type: none"> <li>• Gereedschapouder: ps-System met reduceerhulzen, TRIBOS, spantangopname</li> </ul> |



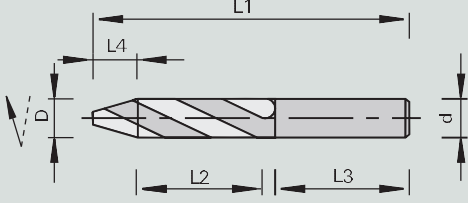

| Producteigenschappen |         |         |          |         |         |   | Bestelinformatie  |   |              |
|----------------------|---------|---------|----------|---------|---------|---|---|---|--------------|
| Ø D [mm]             | L4 [mm] | L2 [mm] | Ø d [mm] | L3 [mm] | L1 [mm] | Z | VE [St.]  | V | Bestelnummer |
| 16                   | 5.0     | 75      | 16       | 48      | 130     | 2 |  | 1 | 50811731     |

## VHW 2269 Ventilatie afwerkrees

Voor de productie van deuren

|   |  |   |   |   |
|---|--|---|---|---|
| Product   | Tekening   | Machine   | Toepassing  | Uitvoering  |
|  |  |  |  |  |

|   |   |           |  |
|---|---|-----------|--|
| Machine / gebruiksaanwijzing  | Uitvoering  | Voordelen | Informatie - Tip   |
| <ul style="list-style-type: none"> <li>• CNC-bewerkingscentra</li> <li>• Voor het boren van de spionboring en voor doorlopende gaten</li> </ul> | <ul style="list-style-type: none"> <li>• Positieve spiraal</li> <li>• n max = 30.000 min-1</li> </ul> |           | <ul style="list-style-type: none"> <li>• Gereedschapouder: ps-System met reduceerhulzen, TRIBOS, spantangopname</li> </ul> |

| Producteigenschappen |         |         |          |         |         |   | Bestelinformatie  |   |              |
|----------------------|---------|---------|----------|---------|---------|---|---|---|--------------|
| Ø D [mm]             | L4 [mm] | L2 [mm] | Ø d [mm] | L3 [mm] | L1 [mm] | Z | VE [St.]  | V | Bestelnummer |
| 12                   | 10      | 47      | 12       | 53      | 110     | 2 |  | 1 | 50811449     |
| 12                   | 10      | 70      | 12       | 50      | 130     | 2 |  | 1 | 50811450     |
| 14                   | 10      | 47      | 14       | 45      | 110     | 2 |  | 1 | 50811070     |
| 16                   | 11      | 52      | 16       | 60      | 130     | 2 |  | 1 | 50811071     |

## VHW 2254 Slotkasten-schrobfree

Voor de productie van deuren

Product



Tekening

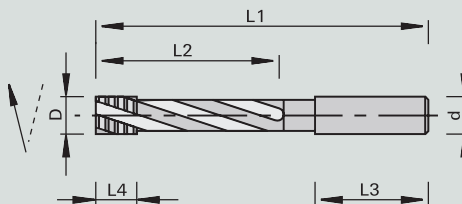

Machine



Toepassing



Uitvoering



Machine / gebruiksaanwijzing

- CNC-bewerkingscentra
- Voor het uitfrezen van slotkasten bij deuren

Uitvoering

- Positieve spiraal
- Snijkanten met spaanbrekers
- Schrobvertanding

Voordelen

- Optimale spaanuitworp naar boven door positieve spiraal
- Zeer rustige loop door spaanbreker

Informatie - Tip

- Gereedschaphouder: ps-System met reduceerhulzen, TRIBOS, spantangopname
- Voor de opspanning in een horizontaal-boor-freesapparaat (Homag, Weeke) zijn zijdelingse spanvlakken nodig
- Meerprijs voor het aanbrengen van Weldon-opspanningen

Producteigenschappen

| Ø D [mm] | L4 [mm] | L2 [mm] | Ø d [mm] | L3 [mm] | L1 [mm] | Z | nmax [min-1] | VE [St.] | V | Bestelnummer |
|----------|---------|---------|----------|---------|---------|---|--------------|----------|---|--------------|
| 16       | 25      | 115     | 16       | 50      | 175     | 3 | 24000        | 1        |   | 50811926     |
| 18       | 25      | 115     | 20       | 50      | 175     | 3 | 24000        | 1        |   | 50811927     |

Bestelinformatie

## VHW 2255 Slotkasten-afwerkfree

Voor de productie van deuren

Product



Tekening

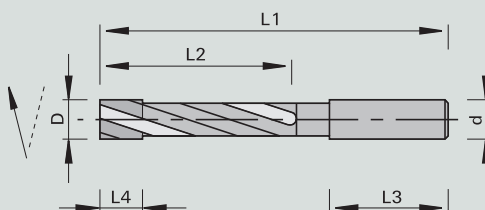

Machine



Toepassing



Uitvoering



Machine / gebruiksaanwijzing

- CNC-bewerkingscentra
- Voor het uitfrezen van de slotkasten en slotplaten bij deuren

Uitvoering

- Positieve spiraal
- Snijkanten met spaanbrekers
- Afwerkvertanding met spaanbreker

Voordelen

- Optimale spaanuitworp naar boven door positieve spiraal
- Zeer rustige loop door spaanbreker

Informatie - Tip





- Gereedschaphouder: ps-System met reduceerhulzen, TRIBOS, spantangopname
- Voor de opspanning in een horizontaal-boor-freesapparaat (Homag, Weeke) zijn zijdelingse spanvlakken nodig
- Meerprijs voor het aanbrengen van Weldon-opspanningen

Producteigenschappen

| Ø D [mm] | L4 [mm] | L2 [mm] | Ø d [mm] | L3 [mm] | L1 [mm] | Z | nmax [min-1] | VE [St.] | V | Bestelnummer |
|----------|---------|---------|----------|---------|---------|---|--------------|----------|---|--------------|
| 14       | 25      | 95      | 14       | 50      | 155     | 2 | 24000        | 1        |   | 50811928     |
| 16       | 25      | 115     | 16       | 50      | 175     | 2 | 24000        | 1        |   | 50811929     |

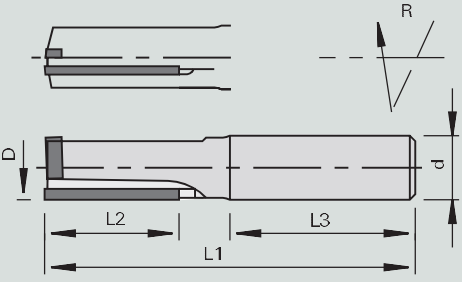
Bestelinformatie

## DP 3501 Schachtfrees

|  |  |  |
|--|--|--|
| <p>Product</p>  | <p>Tekening</p>  | <p>Machine</p>  <p>Toepassing</p>  <p>Uitvoering</p>  |
|--|--|--|

|  |   |  |  |
|--|---|--|--|
| <p>Machine / gebruiksaanwijzing</p> <ul style="list-style-type: none"> <li>• CNC-freesmachines</li> <li>• Voor het aanzetvrij frezen van plaatmateriaal op basis van hout, massief hout en kunststoffen</li> </ul> | <p>Uitvoering</p> <ul style="list-style-type: none"> <li>• Gepolijst spaanvlak en zeer fijn bewerkt vrijloopvlak</li> <li>• Met HW-boorsnijkant voor schuin inboren (gelijktijdige aanzet in Z- en X-as)</li> <li>• Rechte snede</li> <li>• Volhardmetaal element voor <math>\leq \varnothing 10 \text{ mm}</math></li> <li>• Naslijpzone<br/> <math>\varnothing 6 + \varnothing 10 = 0,5 \text{ mm}</math><br/> <math>-\varnothing 12 + \varnothing 16 = 1,2 \text{ mm}</math> </li> </ul> | <p>Voordelen</p> <ul style="list-style-type: none"> <li>• Afwerkkant aan MDF en hardhout soorten</li> <li>• Doorlopende snede</li> <li>• Hoge stabiliteit door speciale uitvoering van de solderingen</li> </ul> | <p>Informatie - Tip</p> <ul style="list-style-type: none"> <li>• Gereedschaphouder: ps-System, TRIBOS, spantangopname</li> <li>• Met schroefdraad voor lengte-instelschroef</li> </ul> |
|--|---|--|--|

| Producteigenschappen |         |                      |         |         |   |                   | Bestelinformatie |  |          |          |               |   |               |
|----------------------|---------|----------------------|---------|---------|---|-------------------|------------------|--|----------|----------|---------------|---|---------------|
| $\varnothing D$ [mm] | L2 [mm] | $\varnothing d$ [mm] | L3 [mm] | L1 [mm] | Z | $n_{max}$ [min-1] | Naslijpzone [mm] |  | VE [St.] | V        | Bestelnr. [L] | V | Bestelnr. [R] |
| 6.0                  | 12      | 12                   | 40      | 60      | 1 | 24000             | 1.0              |  | 1        |          |               |   | 50811684      |
| 8.0                  | 12      | 12                   | 35      | 60      | 1 | 24000             | 0.5              |  | 1        |          |               |   | 50811128      |
| 10                   | 22      | 12                   | 35      | 70      | 2 | 24000             | 0.5              |  | 1        | 50811930 |               |   | 50811130      |
| 12                   | 25.4    | 12                   | 35      | 70      | 1 | 24000             | 1.5              |  | 1        |          |               |   | 50811132      |
| 16                   | 25.4    | 16                   | 45      | 85      | 1 | 24000             | 1.5              |  | 1        |          |               |   | 50811134      |
| 16                   | 35      | 16                   | 45      | 95      | 1 | 24000             | 1.5              |  | 1        |          |               |   | 50811136      |



**DP** **3502 Bovenfrees**  
Z=1+1

Product

Tekening

Machine

Toepassing

Uitvoering

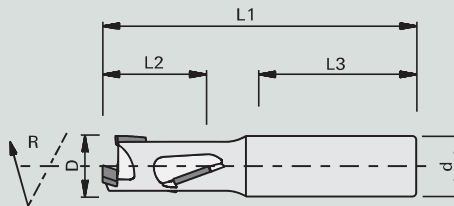

Machine / gebruiksaanwijzing

- CNC-freesmachines
- Voor het voegfreen, sponningfreen, groeffreen en kopieëren in ruw, met melaminehars en papier beplakt, HPL, folie beplakt en gefineerd plaatmateriaal op basis van hout

Uitvoering

- Met DP-boorsnede voor schuin inboren
- Met ashoek
- Meerdere keren naslijpbaar
- n max = 24.000 min-1

Voordelen

- Optimale snijkwaliteit door grotere ashoek, zowel positief als negatief
- Rustig snijgedrag door speciale vorm van de body
- Groeven vanaf een diepte van 4,5 mm zonder inscheuren mogelijk

Informatie - Tip

- Aanvoer maximaal 12 m/min
- Aanbevolen gereedschapshouder: ps-systeem, TRIBOS, warmte-krimphouder
- Zonder schroefdraad voor lengte-instelschroef Zo nodig bij de bestelling opgeven.





Producteigenschappen

Bestelinformatie

| Ø D [mm] | L2 [mm] | Ø d [mm] | L3 [mm] | L1 [mm] | Z   | Naslijpzone [mm] | VE [St.] | V        | Bestelnr. [L] | V | Bestelnr. [R]        |
|----------|---------|----------|---------|---------|-----|------------------|----------|----------|---------------|---|----------------------|
| 10       | 22      | 12       | 40      | 69      | 1+1 | 0.6              | 1        |          |               |   | 58186789 <b>NEUW</b> |
| 12       | 22      | 12       | 40      | 69      | 1+1 | 0.8              | 1        |          |               |   | 58186790 <b>NEUW</b> |
| 12       | 25,4    | 12,7     | 40      | 68      | 1+1 | 1.0              | 1        |          |               |   | 58186791 <b>NEUW</b> |
| 12       | 28      | 12       | 40      | 75      | 1+1 | 0.8              | 1        | 58186793 |               |   | 58186792 <b>NEUW</b> |
| 16       | 22      | 16       | 45      | 78      | 1+1 | 1.0              | 1        |          |               |   | 58186794 <b>NEUW</b> |
| 16       | 28      | 16       | 45      | 83      | 1+1 | 1.0              | 1        |          |               |   | 58186795 <b>NEUW</b> |
| 16       | 35      | 16       | 45      | 90      | 1+1 | 1.0              | 1        | 58186797 |               |   | 58186796 <b>NEUW</b> |
| 18       | 28      | 16       | 45      | 85      | 1+1 | 1.0              | 1        |          |               |   | 58186798 <b>NEUW</b> |
| 18       | 28      | 20       | 45      | 95      | 1+1 | 1.0              | 1        | 58186799 |               |   | 58186800 <b>NEUW</b> |
| 18       | 35      | 16       | 45      | 92      | 1+1 | 1.0              | 1        | 58186801 |               |   | 58186802 <b>NEUW</b> |
| 18       | 35      | 20       | 55      | 102     | 1+1 | 1.0              | 1        | 58186804 |               |   | 58186803 <b>NEUW</b> |
| 18       | 43      | 16       | 45      | 100     | 1+1 | 1.0              | 1        | 58186806 |               |   | 58186805 <b>NEUW</b> |
| 18       | 43      | 20       | 55      | 110     | 1+1 | 1.0              | 1        | 58186808 |               |   | 58186807 <b>NEUW</b> |
| 20       | 35      | 20       | 55      | 102     | 1+1 | 1.0              | 1        |          |               |   | 58186809 <b>NEUW</b> |
| 20       | 52      | 25       | 55      | 120     | 1+1 | 1.0              | 1        | 58186811 |               |   | 58186810 <b>NEUW</b> |

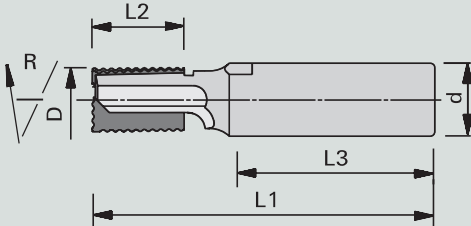
## DP 3511 Highperformance Schrobefrees DP





Voor de bewerking van volkernplaten®

|   |  |   |   |  |
|---|--|---|---|--|
| Product   | Tekening   | Machine   | Toepassing  | Uitvoering   |
|  |  |  |  | <br>1,5 mm<br> |

|  |  |           |   |
|--|--|-----------|---|
| Machine / gebruiksaanwijzing   | Uitvoering   | Voordelen | Informatie - Tip  |
| <ul style="list-style-type: none"> <li>• CNC-freesmachines</li> <li>• Voor het ruw voorbereiden van materiaal op basis van hout, massief hout en kunststoffen</li> <li>• Met name voor de bewerking van massieve kunststofplaten/volkernplaten (bijv. Trespa®, Corian®, Varicor®, LG-HiMacs enz.)</li> </ul> | <ul style="list-style-type: none"> <li>• Highperformance gereedschap voor zowel kantenbewerking als formatteren</li> <li>• Met afwisselende ashoek</li> <li>• Met DP-boorsnede</li> <li>• Ondersnijdend voor schuin inboren</li> <li>• n max = 24.000 min-1</li> </ul> |           | <ul style="list-style-type: none"> <li>• Gereedschaphouder: PS-systeem, TRIBOS, spantangopname</li> <li>• Met schroefdraad voor lengte-instelschroef</li> </ul> |

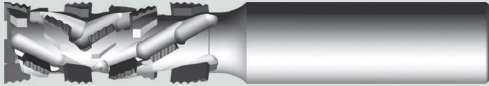
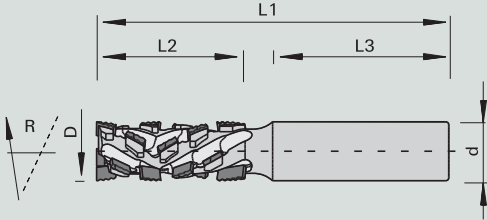
| Producteigenschappen |         |          |         |         |     | Bestelinformatie  |          |              |
|----------------------|---------|----------|---------|---------|-----|---|----------|--------------|
| Ø D [mm]             | L2 [mm] | Ø d [mm] | L3 [mm] | L1 [mm] | Z   |   | VE [St.] | Bestelnummer |
| 14                   | 20      | 16       | 45      | 75      | 2+1 |  | 1        | 50811809     |

## DP 3510 Schrobefrees DP

|   |  |   |   |  |
|---|--|---|---|--|
| Product   | Tekening   | Machine   | Toepassing  | Uitvoering   |
|  |  |  |  | <br>2,0 mm<br> |

|   |  |  |   |
|---|--|--|---|
| Machine / gebruiksaanwijzing  | Uitvoering   | Voordelen  | Informatie - Tip  |
| <ul style="list-style-type: none"> <li>• CNC-freesmachines</li> <li>• Voor het ruw formatteren met aan beide zijden snijranden die niet inscheuren van massief hout en grenen, materiaal op basis van hout en of slijtvast materiaal zoals GFK, HPL-compactplaten en diverse gelaagde materialen op basis van hout</li> <li>• Voor het frezen van uitsparingen en contouren</li> <li>• Voor het inboren bij gelijktijdige aanzet in z-as en x- of y-as</li> </ul> | <ul style="list-style-type: none"> <li>• Met afwisselende ashoek</li> <li>• Met DP-boorsnede</li> <li>• Ondersnijdend voor schuin inboren</li> <li>• Naslijpzone ≥ 2,0 mm</li> <li>• n max = 24.000 min-1</li> </ul> | <ul style="list-style-type: none"> <li>• Voor lange standtijden ook in slijtvaste materialen</li> <li>• Aan beide zijden niet inscheurende snijkanten</li> <li>• Hoog verspanend vermogen</li> </ul> | <ul style="list-style-type: none"> <li>• Snijvlak licht golvend door fijne snedeverdeling</li> <li>• Gereedschaphouder: aanbevolen wordt het gebruik van gereedschap in een precisiehouder zoals de hydro-elastische houders 'ps-systeem', TRIBOS, of de warmtekrimphouder</li> </ul> |

| Producteigenschappen |         |          |         |         |     | Bestelinformatie  |          |              |
|----------------------|---------|----------|---------|---------|-----|---|----------|--------------|
| Ø D [mm]             | L2 [mm] | Ø d [mm] | L3 [mm] | L1 [mm] | Z   |   | VE [St.] | Bestelnummer |
| 20                   | 50      | 20       | 60      | 120     | 2+2 |  | 1        | 50811808     |

## DP 3514 Schrob-afwerkfrees

Product

Tekening

Machine

Toepassing

Uitvoering

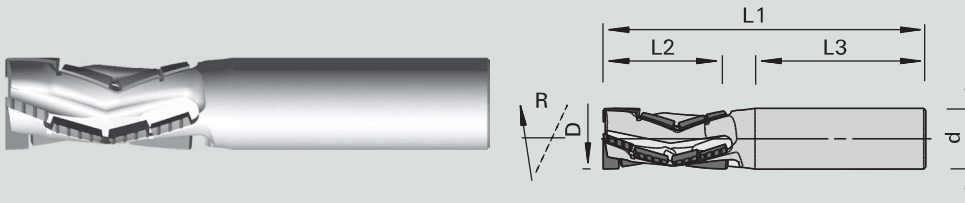

Machine / gebruiksaanwijzing

- CNC-freesmachines
- Voor het formatteren in bijna ruwe kwaliteit met aan beide kanten niet inscheurende snijkanten van massief hout en grenen, houtfijneer en houtcomposiet
- Voor het frezen van uitsparingen en contouren
- Voor het inboren bij gelijktijdige aanzet in z-as en x- of y-as

Uitvoering

- Met afwisselende ashoek
- Met DP-boorsnede
- Ondersnijdend voor schuin inboren
- Naslijpzone  $\geq 1,6$  mm
- $n$  max = 30.000 min<sup>-1</sup>

Voordelen

- Voor lange snijkwaliteit ook in slijtvaste materialen
- Aan beide zijden niet inscheurende snijkanten
- Hoog verspanend vermogen

Informatie - Tip

- Snijvlak licht golvend door fijne snede-verdeling
- Gereedschapshouder: aanbevolen wordt het gebruik van gereedschap in een precisiehouder zoals de hydro-elastische houders 'ps-systeem', TRIBOS, of de warmtekrimphouder

Producteigenschappen

Bestelinformatie

| $\varnothing D$<br>[mm] | L2<br>[mm] | $\varnothing d$<br>[mm] | L3<br>[mm] | L1<br>[mm] | Z       | L |  | VE<br>[St.] | Bestelnummer           |
|-------------------------|------------|-------------------------|------------|------------|---------|---|--|-------------|------------------------|
| 16                      | 32         | 16                      | 45         | 85         | 4 (2+2) | R |  | 1           | 58811950 <b>NIJEUW</b> |

**DP 3503 High performance schachtfrees**  
Z=2+2

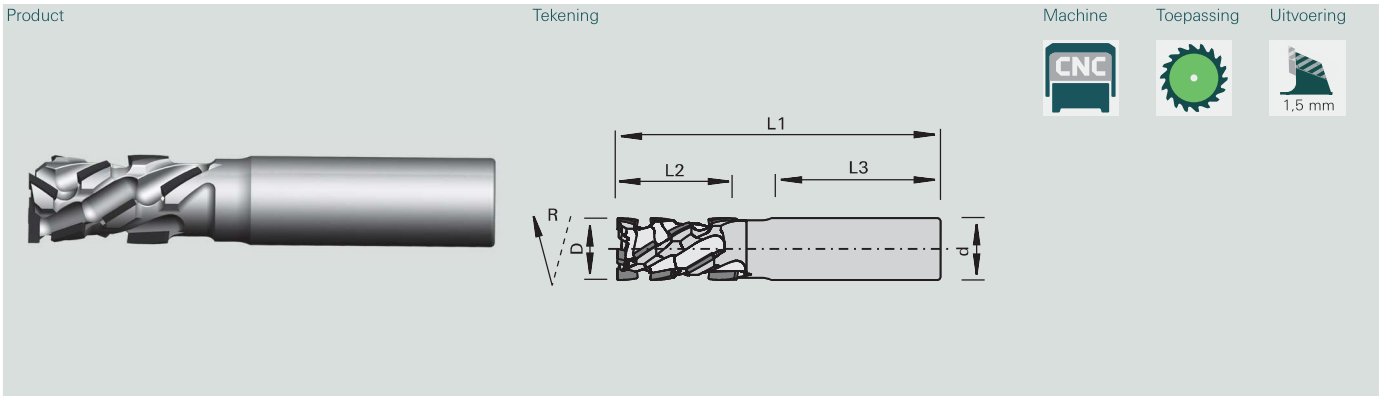

| Machine / gebruiksaanwijzing  | Uitvoering  | Voordelen  | Informatie - Tip  |
|---|---|--|---|
| <ul style="list-style-type: none"> <li>CNC-freesmachines</li> <li>Voor het voegfrezen, sponningfrezen, groeffrezen en kopieëren in ruw, met melaminehars en papier beplakt, HPL, folie beplakt en gefineerd plaatmateriaal op basis van hout</li> </ul> | <ul style="list-style-type: none"> <li>Met DP-boorsnede voor schuin onboren</li> <li>Met scherende snede</li> <li>Naslippzone 1,2 mm</li> <li>n max = 24.000 min-1</li> </ul> | <ul style="list-style-type: none"> <li>Optimale snijkwaliteit door ashoek van boven en onderen trekkend</li> <li>Rustig snijgedrag door 4-vleugelig snijkantpatroon</li> <li>Zeer lange standtijd, lagere snijkraftopname en minder geluid door geoptimaliseerde body</li> </ul> | <ul style="list-style-type: none"> <li>Aanvoer maximaal 12 m/min</li> <li>Gereedschaphouder: ps-System, TRIBOS, spantangopname</li> <li>Met schroefdraad voor lengte-instelschroef</li> </ul> |

| Producteigenschappen |         |          |         |         |     | Bestelinformatie |  |          |          |               |   |               |
|----------------------|---------|----------|---------|---------|-----|------------------|--|----------|----------|---------------|---|---------------|
| Ø D [mm]             | L2 [mm] | Ø d [mm] | L3 [mm] | L1 [mm] | Z   |                  |  | VE [St.] | V        | Bestelnr. [L] | V | Bestelnr. [R] |
| 16                   | 28      | 16       | 45      | 80      | 2+2 |                  |  | 1        |          |               |   | 50186147      |
| 16                   | 38      | 16       | 45      | 90      | 2+2 |                  |  | 1        | 50186149 |               |   | 50186148      |
| 20                   | 28      | 20       | 55      | 95      | 2+2 |                  |  | 1        |          |               |   | 50186150      |
| 20                   | 28      | 25       | 55      | 95      | 2+2 |                  |  | 1        | 50186152 |               |   | 50186151      |
| 20                   | 38      | 20       | 55      | 105     | 2+2 |                  |  | 1        |          |               |   | 50186153      |
| 20                   | 38      | 25       | 55      | 105     | 2+2 |                  |  | 1        | 50186155 |               |   | 50186154      |
| 20                   | 48      | 20       | 55      | 115     | 2+2 |                  |  | 1        |          |               |   | 50186156      |
| 20                   | 48      | 25       | 55      | 115     | 2+2 |                  |  | 1        | 50186158 |               |   | 50186157      |
| 25                   | 65      | 25       | 55      | 130     | 2+2 |                  |  | 1        | 50186160 |               |   | 50186159      |

# DP 3509 Highperformance bovenfrees

Body VHW - DP-Z= 3

Product

Tekening

Machine

Toepassing

Uitvoering

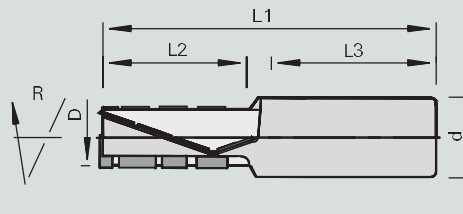

Machine / gebruiksaanwijzing

- CNC-freesmachines
- Voor formaatsneden in ruw, melaminehars- en papierbeplakte, met HPL beplakte en gefineerde plaatmaterialen op basis van hout

Uitvoering

- Body van VHW
- Highperformance gereedschap voor zowel kantenbewerking als formatteren en plaatsnijden volgens nestingmethode
- Met DP-boorsnede
- Ondersnijdend voor schuin inboren
- Aanvoer maximaal 25 m/min
- Naslijzone 2,0 mm
- n max = 24.000 min-1

Voordelen

- Hoge snijkwaliteit en geluidsarm frezen door scherpe snede
- Optimale spaanafvoer door vrijliggend snijkantpatroon
- Optimale instelling van de snijlengtes op de standaardplaatdiktes

Informatie - Tip

- Gereedschaphouder: PS-systeem, TRIBOS, spantangopname

Producteigenschappen

Bestelinformatie

| Ø D [mm] | L2 [mm] | Ø d [mm] | L3 [mm] | L1 [mm] | Z | H [mm] |  | VE [St.] | Bestelnummer         |
|----------|---------|----------|---------|---------|---|--------|--|----------|----------------------|
| 12       | 21      | 16       | 45      | 73      | 3 | 16-19  |  | 1        | 58811842 <b>NEUW</b> |
| 12       | 28      | 16       | 45      | 80      | 3 | 22-25  |  | 1        | 50811804             |
| 12       | 30      | 16       | 45      | 82      | 3 | 28     |  | 1        | 50811805             |

# DP 3505 High performance schachtfrees

Z=3+3

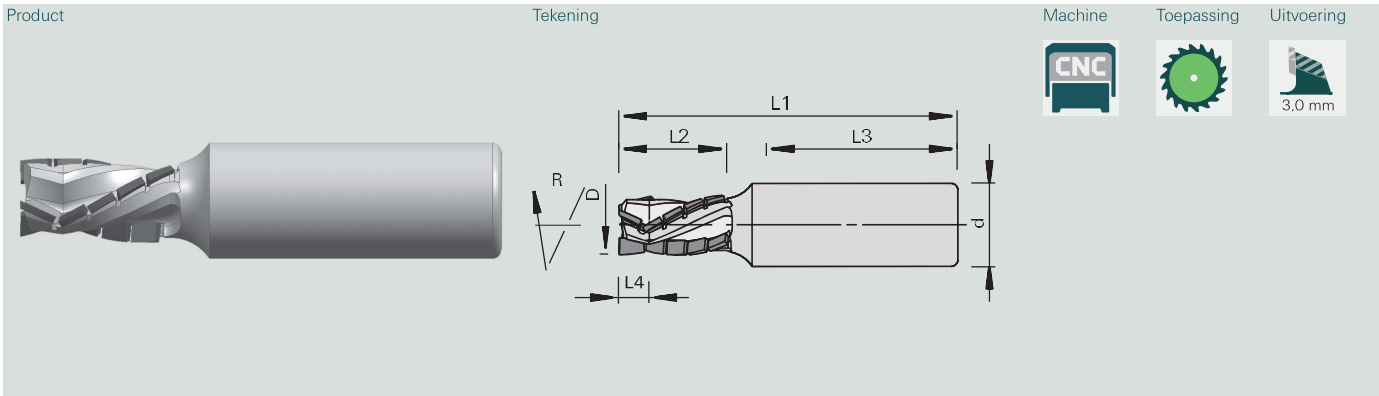

| Machine / gebruiksaanwijzing  | Uitvoering  | Voordelen  | Informatie - Tip  |
|---|---|--|---|
| <ul style="list-style-type: none"> <li>• CNC-freesmachines</li> <li>• Voor formaatsnedes in ruwe, melaminehars- en papierbeplakte, met HPL beplakte en gefineerde plaatmaterialen op basis van hout</li> <li>• High performance gereedschap voor zowel kantenbewerking als formatteren</li> </ul> | <ul style="list-style-type: none"> <li>• Met DP-boornsede voor schuin inboren</li> <li>• Met scherende snede</li> <li>• Naslijpzone 3,0 mm</li> <li>• n max = 24.000 min-1</li> </ul> | <ul style="list-style-type: none"> <li>• Optimale snijkwaliteit door scherende snede, zowel positief als negatief</li> <li>• Rustig snijgedrag door spiraal-zetting van de tanden</li> </ul> | <ul style="list-style-type: none"> <li>• Aanvoer maximaal 30 m/min</li> <li>• Gereedschaphouder: ps-System, TRIBOS, spantangopname</li> <li>• Met schroefdraad voor lengte-instelschroef</li> </ul> |

| Producteigenschappen |         |         |          |         |         |     | Bestelinformatie |          |               |   |                      |
|----------------------|---------|---------|----------|---------|---------|-----|------------------|----------|---------------|---|----------------------|
| Ø D [mm]             | L2 [mm] | L4 [mm] | Ø d [mm] | L3 [mm] | L1 [mm] | Z   | VE [St.]         | V        | Bestelnr. [L] | V | Bestelnr. [R]        |
| 18                   | 28      | 7       | 25       | 55      | 95      | 3+3 | 1                |          |               |   | 58186118 <b>NEUW</b> |
| 20                   | 38      | 7       | 20       | 55      | 105     | 3+3 | 1                |          |               |   | 58186119 <b>NEUW</b> |
| 25                   | 28      | 7       | 25       | 55      | 95      | 3+3 | 1                | 58186121 |               |   | 58186120 <b>NEUW</b> |
| 25                   | 38      | 7       | 25       | 55      | 105     | 3+3 | 1                |          |               |   | 58186122 <b>NEUW</b> |
| 25                   | 48      | 7       | 25       | 55      | 115     | 3+3 | 1                | 58186125 |               |   | 58186124 <b>NEUW</b> |

# DP 3513 High performance schachtfrees CM

Voor nesting - Z=2+2

Product

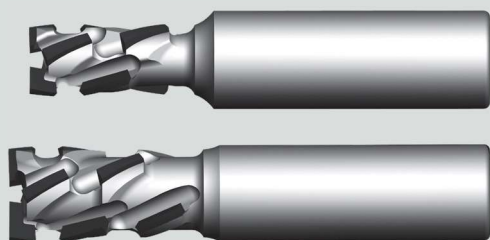

Tekening

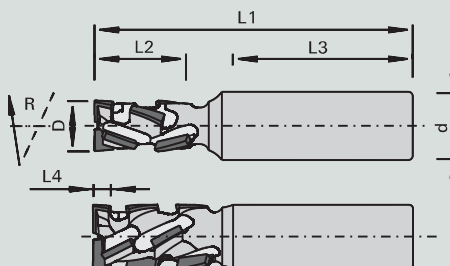

Machine



Toepassing



Uitvoering



Machine / gebruiksaanwijzing

- CNC-freesmachines
- Hoge snijkwaliteit en een nette afwerking (boven en onder) door speciaal aangepaste tweezijdig scherende snede
- Positieve spiraal: optimale spaanuitworp naar boven richting afzuiging
- Negatieve spiraal: spaanuitworp en snijdruk neerwaarts gericht
- Negatieve spiraal speciaal geschikt voor kleinere, c.q. smalle werkstukken en voor groeffrezen
- Z=2+2 = grotere spaanruimtes voor betere spaanafvoer (MDF) en voor minder warmteontwikkeling, in het bijzonder bij de bewerking van multiplex

Uitvoering

- Met DP-boorsnede
- Ondersnijdend voor schuin inboren
- Ø d= 12 mm met versterkte body
- Naslijpzone 1,6 mm
- n max = 24.000 min-1

Voordelen

- Hoge snijkwaliteit en een nette afwerking (boven en onder) door speciaal aangepaste tweezijdig scherende snede
- Positieve spiraal: optimale spaanuitworp naar boven in richting afzuiging
- Negatieve spiraal: spaanuitworp en snijdruk neerwaarts gericht
- Negatieve spiraal speciaal geschikt voor kleinere, c.q. smalle werkstukken en voor groeffrezen

Informatie - Tip

- Gereedschapouder: toepassing in zeer nauwkeurige opspanmidelen aanbevolen (bijv. TRIBOS, ps-System)
- Met schroefdraad voor lengteinstelschroef
- Bij grote aanvoer en dikkere platen zo mogelijk de grotere diameter kiezen
- Snijlengte aan de plaatdikte (H) aanpassen
- \* Opgave "H" bij nesting met beschermplaat

Producteigenschappen

Bestelinformatie

| Ø D<br>[mm] | L2<br>[mm] | L4<br>[mm] | Ø d<br>[mm] | L3<br>[mm] | L1<br>[mm] | Z   | H<br>[mm] | Spiraalrichting | VE<br>[St.] | V | Bestelnummer          |
|-------------|------------|------------|-------------|------------|------------|-----|-----------|-----------------|-------------|---|-----------------------|
| 12          | 22         |            | 16          | 45         | 75         | 2+2 | 16-19*    | Positief        | 1           |   | 58186112 <b>NIEUW</b> |
| 12          | 22         | 4.5        | 16          | 45         | 75         | 2+2 | -19       | Negatief        | 1           |   | 58186113 <b>NIEUW</b> |
| 16          | 28         | 4.5        | 16          | 45         | 80         | 2+2 | -25       | Negatief        | 1           |   | 58186114 <b>NIEUW</b> |

**DP 3506 High performance schachtfrees CM**

Voor nesting - Z=3+3

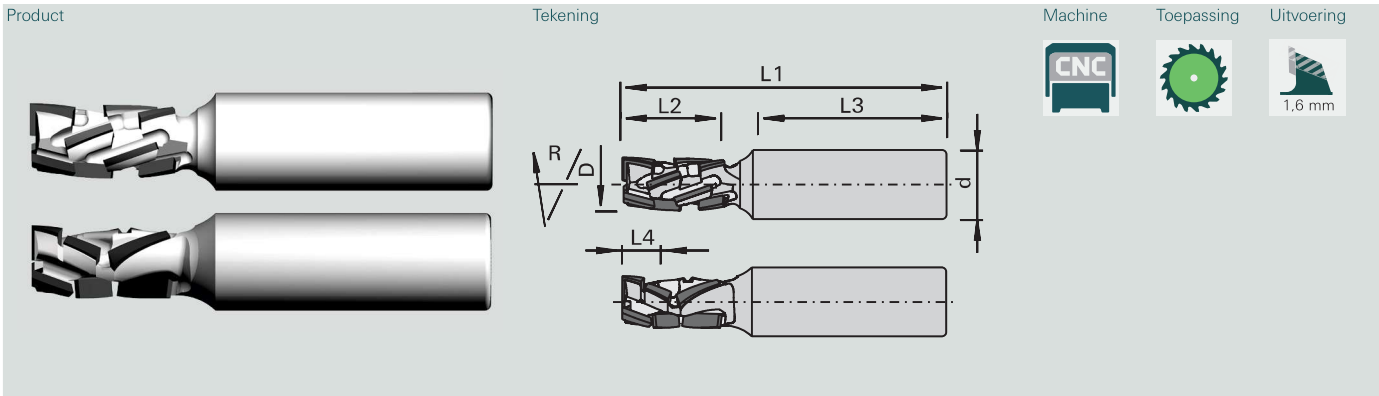

## Machine / gebruiksaanwijzing

- CNC-freesmachines
- Voor op maat maken met het nesting-procedé
- Voor voegfreen, sponningfreen en \*groeffreen (\*negatieve uitvoering) in (on-) beplakte plaatmateriaal op basis van hout

## Uitvoering

- Met DP-boornijkant
- Ondersnijdend voor schuin inboren
- Aanvoer maximaal 25 m/min
- Naslijpzone 1,6 mm
- n max = 30.000 min-1

## Voordelen

- Hoge snijkwaliteit en een nette afwerking (boven en onder) door speciaal aangepaste tweezijdig scherende snede
- Positieve spiraal: optimale spaanuitworp naar boven in richting afzuiging
- Negatieve spiraal: spaanuitworp en snijdruk neerwaarts gericht
- Negatieve spiraal speciaal geschikt voor kleinere, c.q. smalle werkstukken en voor groeffreen

## Informatie - Tip

- Gereedschaphouder: toepassing in zeer nauwkeurige opspanmidelen aanbevolen (bijv. TRIBOS, ps-System)
- Met schroefdraad voor lengteinstelschroef
- Bij grote aanvoer en dikkere platen zo mogelijk de grotere diameter kiezen
- Snijlengte aan de plaatdikte (H) aanpassen
- \* Opgave "H" bij nesting met beschermplaat

## Producteigenschappen

## Bestelinformatie

| Ø D<br>[mm] | L2<br>[mm] | L4<br>[mm] | Ø d<br>[mm] | L3<br>[mm] | L1<br>[mm] | Z   | H<br>[mm] | Spiraalrichting | VE<br>[St.] | V | Bestelnummer         |
|-------------|------------|------------|-------------|------------|------------|-----|-----------|-----------------|-------------|---|----------------------|
| 12          | 22         |            | 16          | 45         | 75         | 3+3 | 16-19 *   | Positief        | 1           |   | 58186571 <b>NEUW</b> |
| 12          | 28         |            | 16          | 45         | 80         | 3+3 | 22-25 *   | Positief        | 1           |   | 58186572 <b>NEUW</b> |
| 16          | 22         |            | 16          | 45         | 75         | 3+3 | 16-19 *   | Positief        | 1           |   | 58186573 <b>NEUW</b> |
| 16          | 28         |            | 16          | 45         | 80         | 3+3 | 22-25 *   | Positief        | 1           |   | 58186574 <b>NEUW</b> |
| 12          | 23         | 7.2        | 16          | 45         | 75         | 3+3 | -19       | Negatief        | 1           |   | 58185518 <b>NEUW</b> |
| 14          | 33         | 7.2        | 16          | 45         | 85         | 3+3 | -30       | Negatief        | 1           |   | 58185799 <b>NEUW</b> |
| 16          | 28         | 7.2        | 16          | 45         | 80         | 3+3 | -25       | Negatief        | 1           |   | 50811803             |



# DP 3507 High performance kantenfrees

Z=4+2+4

Product

Tekening

Machine

Toepassing

Uitvoering

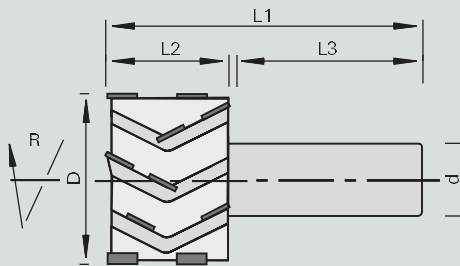

Machine / gebruiksaanwijzing

- CNC-freesmachines
- Voor formaatsnedes in ruw, melaminehars- en papierbeplakt, met HPL beplakt en gefineerd plaatmateriaal op basis van hout

Uitvoering

- High performance gereedschap voor kantenafwerking
- Met ashoek
- Naslijpzone 3,0 mm

Voordelen

- Grote aanvoer (tot 35 m/min) bij goede kantenkwaliteit door aantal tanden Z=4 in de deklaag
- Vermindering van de stofvorming door aantal tanden Z = 2 in de middenpositie
- Golfarme snede door grote buitendiameter van de snijkanten
- Goede snijkwaliteit aan boven- en onderzijde door tweezijdig scherrende snede

Informatie - Tip

- Bij voorkeur voor de nabewerking van voorgeformateerde werkstukken
- Gereedschaphouder: ps-System, TRIBOS, spantangopname
- Met schroefdraad voor lengteinstelschroef

Producteigenschappen

Bestelinformatie

| Ø D [mm] | L2 [mm] | Ø d [mm] | L3 [mm] | L1 [mm] | Z     | H [mm] |  |  |  | VE [St.] | V        | Bestelnr. [L] | Bestelnr. [R]         |
|----------|---------|----------|---------|---------|-------|--------|--|--|--|----------|----------|---------------|-----------------------|
| 48       | 22      | 25       | 62      | 85      | 4+2+4 | 16-19  |  |  |  | 1        |          |               | 58186140 <b>NIEUW</b> |
| 48       | 28      | 25       | 62      | 91      | 4+2+4 | 22-25  |  |  |  | 1        |          |               | 58186142 <b>NIEUW</b> |
| 48       | 35      | 25       | 62      | 98      | 4+2+4 | 28-32  |  |  |  | 1        |          |               | 58186144 <b>NIEUW</b> |
| 48       | 48      | 25       | 55      | 110     | 4+2+4 | 35-45  |  |  |  | 1        | 58186146 |               | 58186145 <b>NIEUW</b> |

# DP 3600 p-systeem highperformance bovenfrees

Z=1+1 / Z=2+2

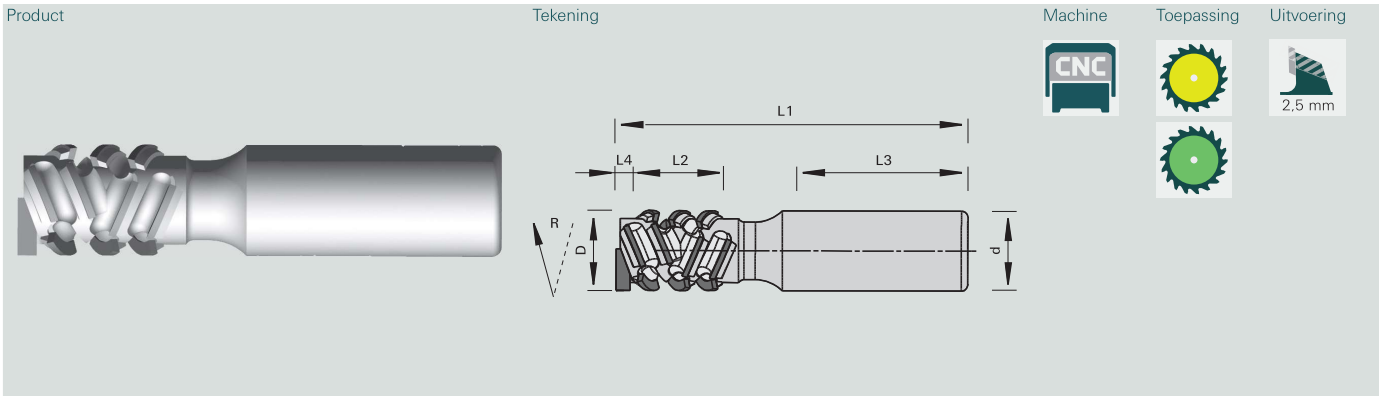

### Machine / gebruiksaanwijzing

- CNC stationair machines
- Voor het inscheurvrije highperformance voegfrees en formatteren van massief hout (knoestvrij) langs en dwars op de nerf
- Voor het highperformance voegfrees en formatteren van melaminehars- en papierbeplakt, HPL, foliebeplakt en gefineerde plaatmaterialen alsook gelakte oppervlakken.
- Met een finish afwerkwaliteit, ook bij vezelplaten en stof- beplakte plaatmaterialen, linoleum met jutevezels, kurk enz.

### Uitvoering

- Extreem trekkende snede
- DP-inboorsnede
- Naslijpzone 2,5 mm

### Voordelen

- Maximale snijkwaliteit en standtijd
- Grote snijdieptes mogelijk
- Schone snedes ook aan de uitvoerzijde
- Zeer geschikt voor laserrandbewerkingen

### Informatie - Tip

- Gereedschap op het midden van de plaatdikte instellen
- Gereedschappen met grondsnode (zie L4) moeten minimaal 4,5 mm uit het werkstuk uitsteken, om de p-System sneden hun werk te laten doen.
- Alleen schuin of circulair insteken
- Aanbevolen aanvoer per tand: materiaal op basis van hout 0,3 - 0,35 mm, massief hout 0,15 - 0,2 mm
- Gereedschapshouder: precisiehouders zoals ps-systeem, TRIBOS
- Met schroefdraad voor lengteinstelschroef
- Draairichting volgens DIN-EN 50144

### Producteigenschappen

| Ø D [mm] | L4 [mm] | L2 [mm] | Ø d [mm] | L3 [mm] | L1 [mm] | Z   | H [mm] | Bestelinformatie |   |               |
|----------|---------|---------|----------|---------|---------|-----|--------|------------------|---|---------------|
|          |         |         |          |         |         |     |        | VE [St.]         | V | Bestelnr. [R] |
| 20       | 3,8     | 29,5    | 25       | 55      | 110     | 1+1 | 26,5   |                  | 1 | 50184380      |
| 25       | 3,8     | 48      | 25       | 55      | 130     | 2+2 | 45     |                  | 1 | 50184384      |

## DP 3610 p-systeem highperformance-voeg-bovenfrees

Product

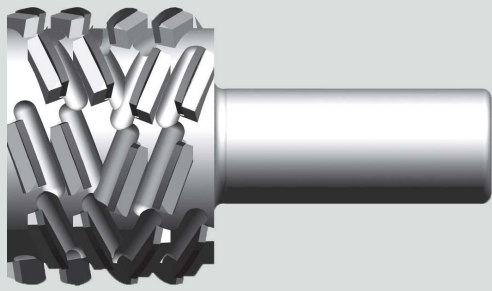

Tekening

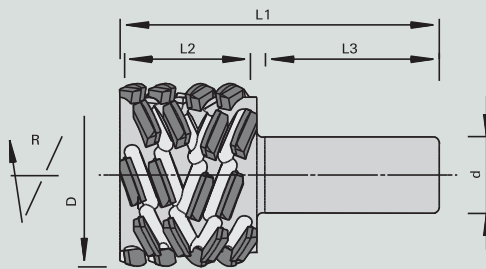

Machine



Toepassing



Uitvoering



Machine / gebruiksaanwijzing

- CNC stationair machines
- Voor het inscheurvrije highperformance frezen van massief hout (knoestvrij) langs en dwars op de nerf
- Voor het highperformance frezen van melaminehars- en papierbeplakt, HPL-, foliebeplakt en gefineerde plaatmaterialen alsook gelakte oppervlakken.
- Met een finish afwerkwaliteit, ook bij vezelplaten en stof- beplakte plaatmaterialen, linoleum met jutevezels, kurk enz.

Uitvoering

- Symmetrische uitvoering
- Niet conisch
- Extreem trekkende snede
- Naslijpzone 4 mm

Voordelen

- Maximale snijkwaliteit en standtijd
- Grote snijdieptes mogelijk
- Schone snedes ook aan de uitvoerzijde
- Zeer geschikt voor laserrandbewerkingen

Informatie - Tip

- Met schroefdraad voor lengteinstelschroef
- Aanbevolen aanvoer per tand: materiaal op basis van hout 0,55 mm, massief hout 0,28 mm
- Op aanvraag ook in conische uitvoering mogelijk
- Gereedschapshouder: precisiehouders zoals ps-systeem, TRIBOS
- Draairichting volgens DIN-EN 50144

Producteigenschappen

Bestelinformatie

| Ø D [mm] | L2 [mm] | Ø d [mm] | L3 [mm] | L1 [mm] | Z   |             |  | VE [St.] | V | Bestelnr. [R] |
|----------|---------|----------|---------|---------|-----|-------------|--|----------|---|---------------|
| 60       | 38      | 25       | 57.4    | 105     | 3+3 | symmetrisch |  | 1        | # | 50184083      |

## DP 3620 p-systeem highperformance-groeffrees

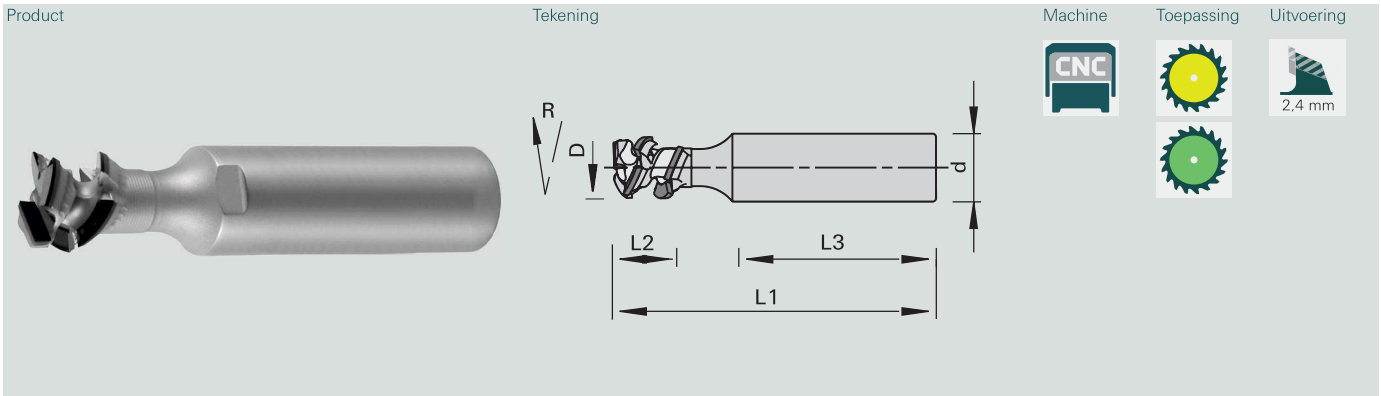

Machine



Toepassing



Uitvoering



2,4 mm

Machine / gebruiksaanwijzing

- CNC stationair machines
- Voor groeven en uitsparingen in plaatmaterialen
- Voor het inscheurvrije highperformance frezen van massief hout (knoestvrij), langs en dwars op de nerf
- Voor het highperformance groeffrezen van melaminehars- en papierbeplakt, HPL-, foliebeplakt en gefineerde plaatmaterialen alsook gelakte oppervlakken.
- Met een finish afwerkkwaliteit, ook bij vezelplaten en stof-beplakte plaatmaterialen, linoleum met jutevezels, kurk enz.

Uitvoering

- Extreem trekkende snede
- Naslijpzone kopse kant 1,8 mm, omvangzijde 2,4 mm

Voordelen

- Maximale snijkwaliteit en standlengte
- Schone snedes ook aan de uitvoerzijde

Informatie - Tip

- Minimale groefdiepte 0,5 mm
- Vanaf 25 mm is Z=2 mogelijk, basissnede altijd Z=1
- Gebogen grondsede voor superfijne afwerking
- Alleen axiaal inboren
- Aanbevolen aanvoer per tand: materiaal op basis van hout 0,3 - 0,35 mm, massief hout 0,15 - 0,2
- Gereedschapshouder: precisiehouders zoals ps-systeem, TRIBOS, warmtekrimphouder
- Met schroefdraad voor lengteinstelschroef
- Draairichting volgens DIN-EN 50144



Producteigenschappen

Bestelinformatie

| Ø D [mm] | L2 [mm] | Ø d [mm] | L3 [mm] | L1 [mm] | Z   | Ashoek [°] | VE [St.] | V | Bestelnr. [R]        |
|----------|---------|----------|---------|---------|-----|------------|----------|---|----------------------|
| 18       | 7,0     | 20       | 53      | 90      | 1+1 | 70         | 1        |   | 50184772             |
| 18       | 19      | 20       | 55      | 95      | 1+1 | 70         | 1        |   | 58185614 <b>NEUW</b> |

## HW 1594 Vlakfrees

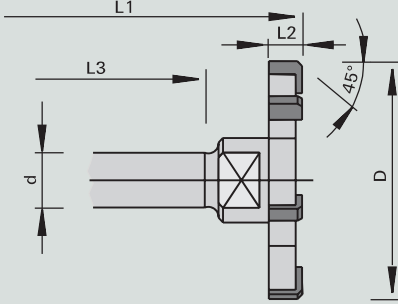



Z=6

|         |  |   |   |   |
|---------|--|---|---|---|
| Product | Tekening   | Machine   | Toepassing  | Uitvoering  |
|         |  |  |  | <ul style="list-style-type: none"> <li>HW TC05</li> <li>MAN</li> <li>MEC</li> </ul> |

|   |  |           |                  |
|---|--|-----------|------------------|
| Machine / gebruiksaanwijzing  | Uitvoering   | Voordelen | Informatie - Tip |
| <ul style="list-style-type: none"> <li>CNC-machines</li> <li>Handbovenfreesen</li> <li>Voor het vlakfreesen van uitstekende afdekklagen, verlijmdde delen enz. bij massief hout of materiaal op basis van hout</li> </ul> | <ul style="list-style-type: none"> <li>Snedes: HW-belegd met fase</li> <li>Handmatige aanvoer</li> </ul> |           |                  |

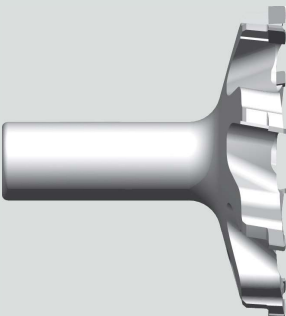
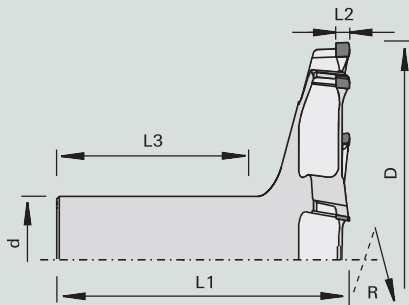
| Producteigenschappen |         |          |         |         |   | Bestelinformatie |   |              |  |
|----------------------|---------|----------|---------|---------|---|------------------|---|--------------|--|
| Ø D [mm]             | L2 [mm] | Ø d [mm] | L3 [mm] | L1 [mm] | Z | VE [St.]         | V | Bestelnummer |  |
| 52                   | 7       | 12       | 40      | 60      | 6 | 1                | o | 50811814     |  |

## DP 3508 Vlak- en sponningschachtfrees

|   |  |   |   |   |
|---|--|---|---|---|
| Product   | Tekening   | Machine   | Toepassing  | Uitvoering  |
|  |  |  |  |  |

|   |  |  |  |
|---|--|--|--|
| Machine / gebruiksaanwijzing  | Uitvoering   | Voordelen  | Informatie - Tip   |
| <ul style="list-style-type: none"> <li>CNC-freesmachines</li> <li>Voor het vlakfreesen van plaatmaterialen</li> </ul> | <ul style="list-style-type: none"> <li>Snijmateriaal DP</li> <li>Naslijpzone 3,5 mm</li> </ul> | <ul style="list-style-type: none"> <li>Hoog verspanend vermogen bij het gladmaken van de werkbladen, bijv. bij het nesting-procédé</li> <li>Gladde en vlakke oppervlakken door speciale snijkantgeometrie</li> </ul> | <ul style="list-style-type: none"> <li>Met schroefdraad voor lengteinstel-schroef</li> <li>Draairichting volgens DIN-EN 50144</li> </ul> |

| Producteigenschappen |         |          |         |         |   | Bestelinformatie |          |   |              |
|----------------------|---------|----------|---------|---------|---|------------------|----------|---|--------------|
| Ø D [mm]             | L2 [mm] | Ø d [mm] | L3 [mm] | L1 [mm] | Z | nmax [min-1]     | VE [St.] | V | Bestelnummer |
| 100                  | 5,6     | 25       | 59,3    | 90      | 8 | 24000            | 1        | s | 50811708     |

## HW 5572 Vlakfrees- en sponningfrees

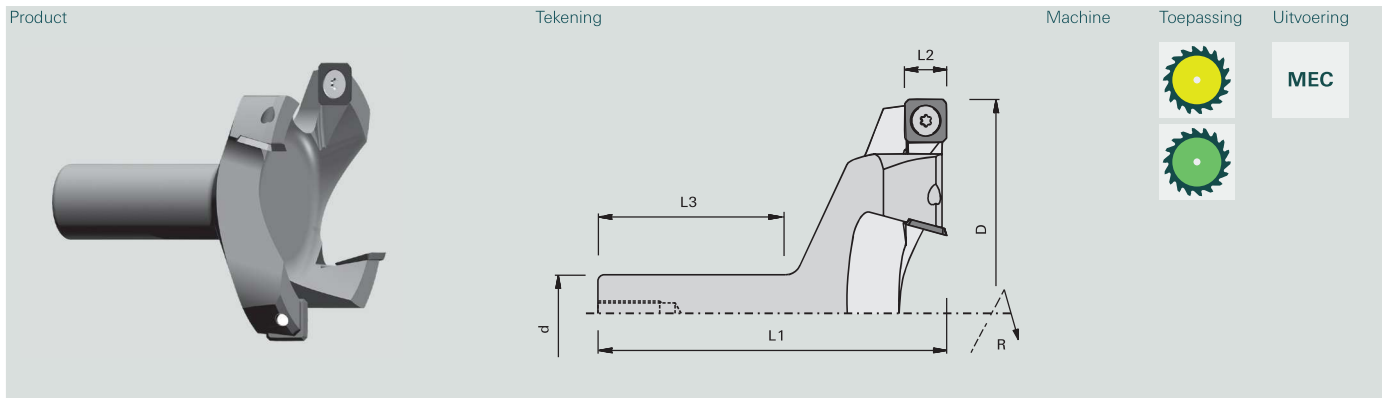

Machine Toepassing Uitvoering



MEC

|  |  |   |  |
|--|--|---|--|
| <p>Machine / gebruiksaanwijzing</p> <ul style="list-style-type: none"> <li>• CNC-freesmachines</li> <li>• Voor het vlakfrezen van plaatmaterialen</li> </ul> | <p>Uitvoering</p> <ul style="list-style-type: none"> <li>• Snijmateriaal TC25</li> </ul> | <p>Voordelen</p> <ul style="list-style-type: none"> <li>• Hoog verspanend vermogen bij het gladmaken van de werkbladen, bijv. bij het nesting-procédé</li> <li>• Gladde en vlakke oppervlakken door speciale snijkantgeometrie</li> </ul> | <p>Informatie - Tip</p> <ul style="list-style-type: none"> <li>• Met schroefdraad voor lengte-instelschroef</li> <li>• Draairichting volgens DIN-EN 50144</li> </ul> |
|--|--|---|--|

| Producteigenschappen                              |         |          |               |         |        |              | Bestelinformatie |  |          |   |              |
|---|---------|----------|---------------|---------|--------|--------------|------------------|--|----------|---|--------------|
| Ø D [mm]  | L2 [mm] | Ø d [mm] | L3 [mm]       | L1 [mm] | Z      | nmax [min-1] |                  |  | VE [St.] | V | Bestelnummer |
| 100   | 14      | 25       | 55            | 96      | 4      | 15200        |                  |  | 1        |   | 50811806     |
| Omkeermessen                                      |         |          | B [mm]        | H [mm]  | S [mm] |              |                  |  | VE [St.] | V | Bestelnummer |
|   |         |          | 14            | 14      | 2.0    |              |                  |  | 10       |   | 182441       |
| Toebehoren  |         |          | Afmeting [mm] |         |        |              |                  |  | VE [St.] |   | Bestelnummer |
| Schroevendraaier met haakse greep voor binnentorx |         |          | T20x100       |         |        |              |                  |  | 1        |   | 166092       |
| Kruiskopschroeven - met binnentorx                |         |          | M5x6 T20      |         |        |              |                  |  | 10       |   | 176199       |

# HW 5575 Spiraal schaafkoppen

Met HW-omkeermes

Product



Tekening

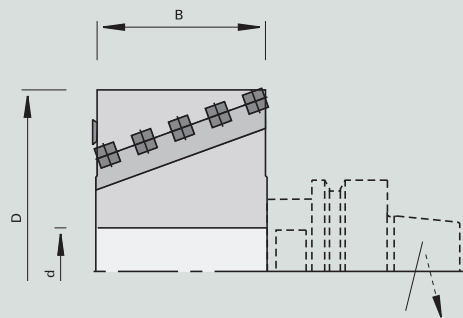

Machine



Toepassing



Uitvoering



Machine / gebruiksaanwijzing

- Stationaire freescentra
- Voor het gladmaken, voorschaven en naschaven van massief hout

Uitvoering

- Met vierzijdig snijdende convexe omkeermessen
- Spiraalvormig patroon van de omkeermessen en snede-verdeling
- Body van gelegeerd aluminium

Voordelen

- Gemakkelijk verspanen, minimale snijdruk en geluidsarm

Informatie - Tip

- Voor HSK-opnemedoorn met dubbele spiebaan zonder tussenringen
- Voor ident.nr. 58665 105 houderlengte 50 mm bij HSK63-opspandoorn (183748)
- Voor ident.nr. 58665 106 houderlengte 80 mm bij HSK63-opspandoorn (183749)

Producteigenschappen

Bestelinformatie

| Ø D [mm]                        | B [mm] | Ø d [mm] | Z             | n <sub>max</sub> [min-1] |        |        |        |               | VE [St.] | V Bestelnummer          |
|---------------------------------|--------|----------|---------------|--------------------------|--------|--------|--------|---------------|----------|-------------------------|
| 80                              | 80     | 30       | 2+2+v2        | 18000                    |        |        |        |               | 1        | 58665 105 <b>NEUW</b>   |
| 80                              | 100    | 30       | 2+2+v2        | 18000                    |        |        |        |               | 1        | s 58665 106 <b>NEUW</b> |
| Omkeermessen                    |        |          |               |                          | B [mm] | H [mm] | S [mm] | Snijmateriaal | VE [St.] | V Bestelnummer          |
| Omkeermessen (gewelfd R=150 mm) |        |          |               |                          | 15     | 15     | 2.5    | TCw20         | 10       | 185274 <b>NEUW</b>      |
| Toebehoren                      |        |          | Afmeting [mm] |                          |        |        |        |               | VE [St.] | V Bestelnummer          |
| Verzonken kop-schroeven         |        |          | M5x15,5 T20   |                          |        |        |        |               | 10       | 182112                  |
| Schroevendraaier                |        |          | T20x100       |                          |        |        |        |               | 1        | 166092                  |

# HW 5576 Groef- en sponningfrees

Gemonteerd op HSK63F opspandoorn

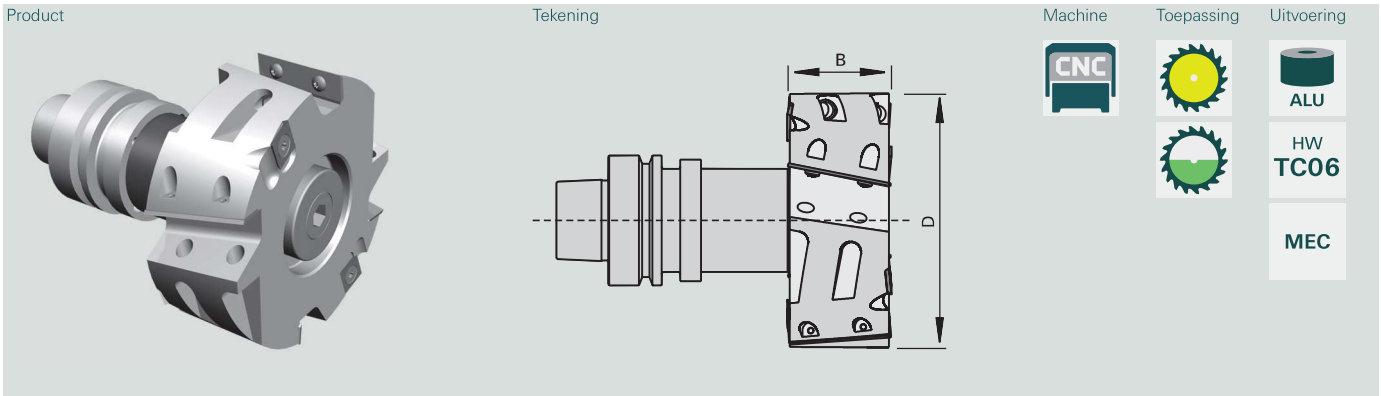

- |  |   |  |   |
|--|---|--|---|
| <p><b>Machine / gebruiksaanwijzing</b></p> <ul style="list-style-type: none"> <li>• CNC-freesmachines</li> <li>• Voor het braamvrij voegfreesen en groeffreesen in massief hout en plaatmateriaal op basis van hout</li> <li>• Voor gecoat, niet-gecoat en verlijmd massief hout en sterk slijtende houtsoorten</li> </ul> | <p><b>Uitvoering</b></p> <ul style="list-style-type: none"> <li>• Met afwisselende ashoek voor trekkende snede</li> <li>• Snijmateriaal HW TC06</li> <li>• Freesbody van gelegeerd aluminium</li> <li>• Voorsnijders: 2 boven en 2 onder</li> </ul> | <p><b>Voordelen</b></p> <ul style="list-style-type: none"> <li>• Optimale snijkwaliteit</li> </ul> | <p><b>Informatie - Tip</b></p> <ul style="list-style-type: none"> <li>• Gemonteerd op HSK63F opspandoorn inclusief vulring</li> </ul> |
|--|---|--|---|

| Producteigenschappen             |        |          |                            |          |                   | Bestelinformatie |          |        |                      |          |   |              |
|----------------------------------|--------|----------|----------------------------|----------|-------------------|------------------|----------|--------|----------------------|----------|---|--------------|
| Ø D [mm]                         | B [mm] | Ø d [mm] | Z                          | DKN [mm] | nmin-nmax [min-1] |                  | VE [St.] | V      | Bestelnr. [L]        |          |   |              |
| 125                              | 50     | 30       | 2+2 V2+2                   | 8x3      | 10600             |                  | 1        |        | 58665108 <b>NEUW</b> |          |   |              |
| Omkeermessen                     |        |          |                            |          |                   | B [mm]           | H [mm]   | S [mm] | Snijmateriaal        | VE [St.] | V | Bestelnummer |
| Voorsnijders                     |        |          |                            |          |                   | 14               | 14       | 2.0    | TCw30                | 10       |   | 003079       |
| Omkeermessen                     |        |          |                            |          |                   | 50               | 12       | 1.5    | TC06                 | 10       |   | 178289       |
| Toebehoren                       |        |          | Afmeting [mm]              |          |                   |                  | VE [St.] | V      | Bestelnummer         |          |   |              |
| 5576 groef- en sponningmessenkop |        |          | 125x50x30 Z2+2 V2+2 DKN8x3 |          |                   |                  | 1        |        | 58665107 <b>NEUW</b> |          |   |              |
| Opspandoorn met HSK-schacht      |        |          | Ø30x80xHSK 63F             |          |                   |                  | 1        |        | 183749               |          |   |              |
| Verzonken kopschroeven           |        |          | M5x6 T20                   |          |                   |                  | 10       |        | 176199               |          |   |              |
| Rondkopschroeven                 |        |          | M3,5x12 T15                |          |                   |                  | 10       |        | 171067               |          |   |              |
| Toebehoren                       |        |          | Afmeting [mm]              |          |                   |                  | VE [St.] | V      | Bestelnummer         |          |   |              |
| Schroevendraaier                 |        |          | T15                        |          |                   |                  | 1        |        | 163161               |          |   |              |
| Schroevendraaier                 |        |          | T20x100                    |          |                   |                  | 1        |        | 166092               |          |   |              |



# HW 1591 Siergroeffrees

Met HW-omkeermes

Product

Tekening

Machine

Toepassing

Uitvoering

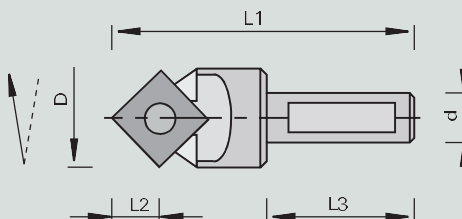
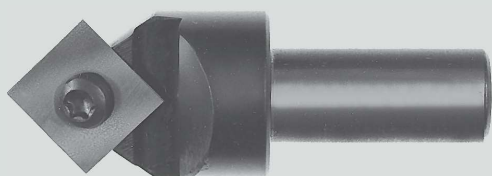

Machine / gebruiksaanwijzing

- Handbovenfreesen
- CNC-freesmachines
- Voor het frezen van siergroeven, tekst en gravures in massief hout en plaatmateriaal op basis van hout

Uitvoering

- Met negatieve ashoek
- Tandbezetting: HW TC05

Voordelen

- Braamvrij frezen van beplakt plaatmateriaal op basis van hout door negatieve ashoek

Informatie - Tip

- Opname: ps-systeem met reduceerhulzen, spantangopname gecombineerd met deze frezen als gereedschap set
- Leveringsomvang: bestelnummer 50811713 frees compleet met omkeermes bestelnummer 50820012 óf "set" bestelnummer 50811728: 1x siergroeffrees 50811713 incl. 2x profielmes (Profiel: bestelnummer aangeven zoals in schets hieronder weergegeven!!)

Producteigenschappen

| Ø D [mm] | L2 [mm] | Ø d [mm] | L3 [mm] | L1 [mm] | Z | VE [St.] | V | Bestelnummer         |
|----------|---------|----------|---------|---------|---|----------|---|----------------------|
| 17       | 8,3     | 10       | 21      | 48      | 1 | 1        | # | 50811713             |
|          |         |          |         |         |   | Set      |   | 50811728             |
| 17       | 8,3     | 10       | 40      | 67      | 1 | 1        |   | 58186880 <b>NEUW</b> |

Bestelinformatie

| Omkeermessen            | B [mm] | H [mm] | S [mm] | Snijmateriaal | VE [St.] | V | Bestelnummer |
|-------------------------|--------|--------|--------|---------------|----------|---|--------------|
| Omkeermessen            | 12     | 12     | 1.5    | TC05          | 10       |   | 50820012     |
| Profiel-omkeermessen HW | 11     | 12     | 1.5    | TC05          | 10       | s | 50825017     |
| Profiel-omkeermessen HW | 11     | 12     | 1.5    | TC05          | 10       | s | 50825018     |
| Profiel-omkeermessen HW | 11     | 12     | 1.5    | TC05          | 10       | s | 50825019     |
| Profiel-omkeermessen HW | 12     | 12     | 1.5    | TC05          | 10       | s | 50825020     |
| Profiel-omkeermessen HW | 12     | 12     | 1.5    | TC05          | 10       | s | 50825021     |

| Toebehoren           | Afmeting [mm] | VE [St.] | V | Bestelnummer |
|----------------------|---------------|----------|---|--------------|
| Cilinderkopschroeven | M3,5x6,5 T15  | 10       |   | 163223       |
| Schroevendraaier     | T15           | 1        |   | 163161       |

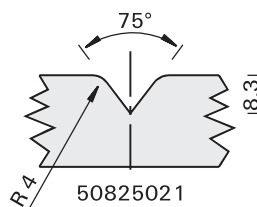
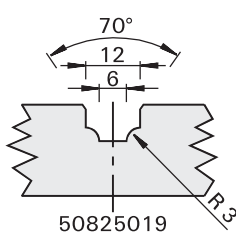
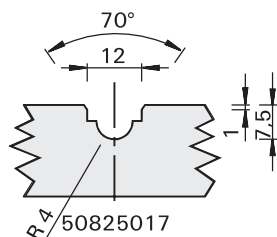
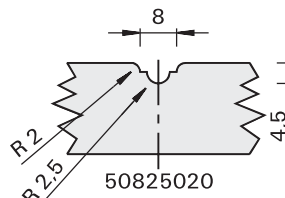
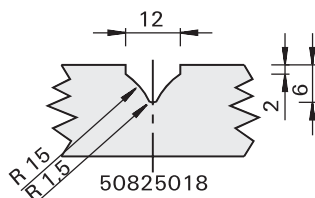
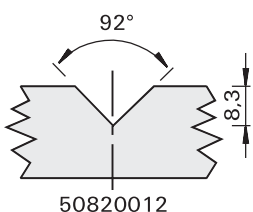

# HW 1581 Zwenkfrees met HW- omkeermessen

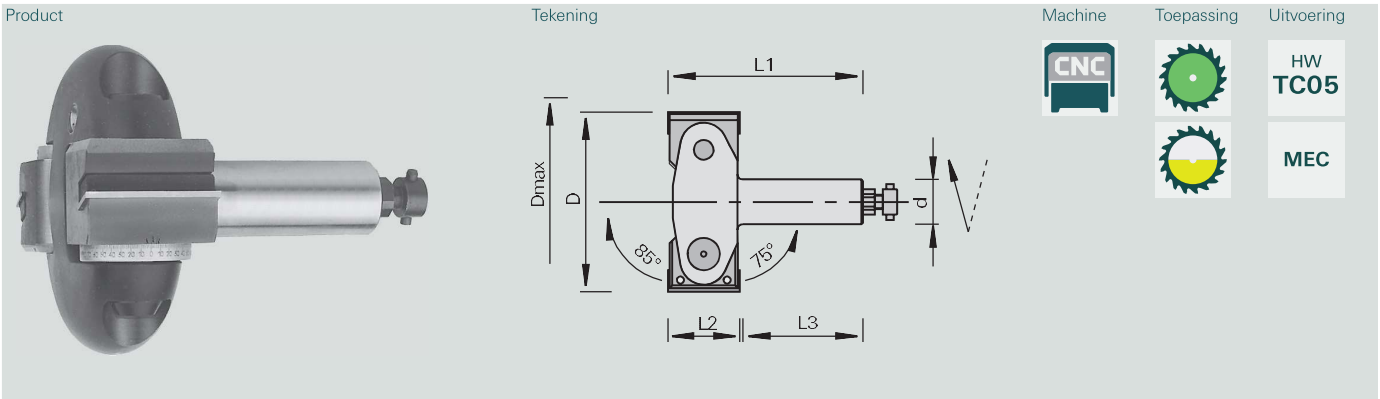

Machine:

Toepassing:

Uitvoering: HW TC05, MEC

**Machine / gebruiksaanwijzing**

- CNC-freesmachines
- Bovenfreesen
- Voor het kantenbewerken, aanfasen en vlakken van massief hout en plaatmateriaal op basis van hout
- Voor het sponningfreesen deze omkeermessen monteren: bestelnummer 50825010

**Uitvoering**

- Snijkanten asparallel
- Tandbezetting: HW TC05
- n max = 12.000 min-1

**Voordelen**

- universele toepassing

**Informatie - Tip**

- Fase op zeer nauwkeurige schaal instelbaar van 0 - 85 graden
- Geschikt voor handmatige aanvoer
- Gereedschaphouder: ps-System, TRIBOS, spantangopname, MK2 direct in de spindel

| Producteigenschappen |             |         |               |         |         |        | Bestelinformatie |        |               |                |                |
|----------------------|-------------|---------|---------------|---------|---------|--------|------------------|--------|---------------|----------------|----------------|
| Ø D [mm]             | Ø Dmax [mm] | L2 [mm] | Ø d [mm]      | L3 [mm] | L1 [mm] | Z      |                  |        | VE [St.]      | V Bestelnummer |                |
| 100                  | 117         | 40      | 25            | 55      | 110     | 2      |                  |        | 1             | 50811714       |                |
| Omkeermessen         |             |         |               |         |         | B [mm] | H [mm]           | S [mm] | Snijmateriaal | VE [St.]       | V Bestelnummer |
| Omkeermessen         |             |         |               |         |         | 40     | 12               | 1.5    | TC05          | 10             | 50820040       |
| Toebehoren           |             |         | Afmeting [mm] |         |         |        |                  |        | VE [St.]      | V Bestelnummer |                |
| Veiligheidsschroeven |             |         | M8x25         |         |         |        |                  |        | 1             | 172113         |                |
| Veiligheidsschroeven |             |         | M8x19         |         |         |        |                  |        | 1             | 172921         |                |
| Schroevendraaier     |             |         | SW3x100       |         |         |        |                  |        | 1             | 166090         |                |

**HW 5573 Folding-fasfrees**  
Z=1

Product

Tekening

Machine

Toepassing

Uitvoering

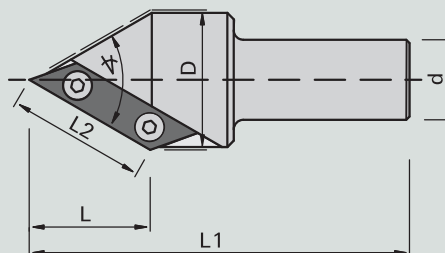
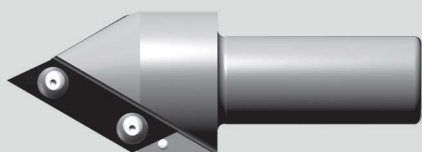

Machine / gebruiksaanwijzing

- CNC-5-assige freesmachines
- Voor het uitfrezen van hoeken en het afschuiven van siergroeven en foldingsnedes in massief hout en materiaal op basis van hout

Uitvoering

- Met schacht
- n max = 15.000 min-1

Voordelen

Informatie - Tip

- Houders apart bestellen
- Houdersystemen: ps-systeem, TRIBOS, warmtekrimphouder, spantanghouder

Producteigenschappen

Bestelinformatie

| Wighoek [°]      | Ø D [mm] | L2 [mm]       | Ø d [mm] | L3 [mm] | L1 [mm] | Z      |               | VE [St.] | Bestelnummer   |
|------------------|----------|---------------|----------|---------|---------|--------|---------------|----------|----------------|
| 60               | 41,5     | 41,3          | 25       | 55      | 118     | 1      |               | 1        | 50811807       |
| Omkeermessen     |          |               |          | B [mm]  | H [mm]  | S [mm] | Snijmateriaal | VE [St.] | V Bestelnummer |
|                  |          |               |          | 50      | 12      | 1,5    |               | 10       | 185140         |
| Toebehoren       |          | Afmeting [mm] |          |         |         |        |               | VE [St.] | V Bestelnummer |
| Rondkopschroeven |          | M3,5x4 T15    |          |         |         |        |               | 10       | 168893         |
| Schroevendraaier |          | T15           |          |         |         |        |               | 1        | 163161         |

## HW 1521 Zwaluwstaartfrees met fase 15°

Product Tekening Machine Toepassing Uitvoering

Machine: CNC  
Toepassing:   
Uitvoering: HW TCw05, MAN, MEC

Machine / gebruiksaanwijzing      Uitvoering      Voordelen      Informatie - Tip

- Handbovenfrezen
- CNC-machines
- Voor het frezen van zwaluwstaart-verbindingen en voor speciale werkzaamheden bij de Corian®-bewerking
- Voor 15° fase

- Body met 2 HW-omkeermessen met fase aan beide zijden
- Aanslagpen voor probleemloos verwisselen van de messen
- Voor handmatige en mechanische aanvoer
- Fase 15°

| Producteigenschappen |         |          |         |         |   | Bestelinformatie |        |          |                |          |                |
|----------------------|---------|----------|---------|---------|---|------------------|--------|----------|----------------|----------|----------------|
| Ø D [mm]             | L2 [mm] | Ø d [mm] | L3 [mm] | L1 [mm] | Z |                  |        | VE [St.] | V Bestelnummer |          |                |
| 28                   | 26      | 12       | 40      | 70      | 2 |                  |        | 1        | o 50811817     |          |                |
| Omkeermessen         |         |          |         |         |   | B [mm]           | H [mm] | S [mm]   | Snijmateriaal  | VE [St.] | V Bestelnummer |
| Omkeermessen         |         |          |         |         |   | 27               | 9      | 1.5      | TCw05          | 10       | o 50811818     |

## HW 1522 Fasefrees Z=2

Product Tekening Machine Toepassing Uitvoering

Machine: CNC  
Toepassing:   
Uitvoering: HW TC05, MEC

Machine / gebruiksaanwijzing      Uitvoering      Voordelen      Informatie - Tip

- Conventionele bovenfrezen
- CNC-machines
- Voor het afschuiven van plaatmateriaal

- Body met 2 HW-omkeermessen
- Alleen omvangsnijdend
- Fase 45°
- Mechanische aanvoer

| Producteigenschappen |           |         |          |         |         |   | Bestelinformatie |        |          |                |          |                |
|----------------------|-----------|---------|----------|---------|---------|---|------------------|--------|----------|----------------|----------|----------------|
| Ø D [mm]             | Ø D1 [mm] | L2 [mm] | Ø d [mm] | L3 [mm] | L1 [mm] | Z |                  |        | VE [St.] | V Bestelnummer |          |                |
| 74                   | 17        | 28      | 25       | 55      | 95      | 2 |                  |        | 1        | o 50811819     |          |                |
| Omkeermessen         |           |         |          |         |         |   | B [mm]           | H [mm] | S [mm]   | Snijmateriaal  | VE [St.] | V Bestelnummer |
| Omkeermessen         |           |         |          |         |         |   | 50               | 12     | 1.5      | TC05           | 10       | 50820050       |

## HW 1520 Handgrefrezen Z=2

|         |          |         |            |   |    |      |     |     |
|---------|----------|---------|------------|---|----|------|-----|-----|
| Product | Tekening | Machine | Toepassing | Uitvoering  |    |      |     |     |
|         |          |         |            | <table border="1"> <tr><td>HW</td></tr> <tr><td>TC05</td></tr> <tr><td>MAN</td></tr> <tr><td>MEC</td></tr> </table> | HW | TC05 | MAN | MEC |
| HW      |          |         |            |   |    |      |     |     |
| TC05    |          |         |            |   |    |      |     |     |
| MAN     |          |         |            |   |    |      |     |     |
| MEC     |          |         |            |   |    |      |     |     |

|   |  |           |   |
|---|--|-----------|---|
| Machine / gebruiksaanwijzing  | Uitvoering   | Voordelen | Informatie - Tip  |
| <ul style="list-style-type: none"> <li>Voor het frezen van blinde greeplijsten in massief hout, plaatmateriaal en plaatwerk op basis van hout</li> <li>De complete greeplijst kan in één keer worden gemaakt aan de lade- en kastdeurfronten</li> </ul> | <ul style="list-style-type: none"> <li>Twee asparallelle messen</li> <li>Omvang - en ondersnijdend</li> <li>Rechtloop</li> <li>Handmatige aanvoer</li> </ul> |           | <ul style="list-style-type: none"> <li>Andere schachtdiameters op aanvraag</li> </ul> |

| Producteigenschappen |         |         |         |          |         |         |   | Bestelinformatie |          |   |              |
|----------------------|---------|---------|---------|----------|---------|---------|---|------------------|----------|---|--------------|
| Ø D [mm]             | R1 [mm] | R2 [mm] | L2 [mm] | Ø d [mm] | L3 [mm] | L1 [mm] | Z |                  | VE [St.] | V | Bestelnummer |
| 19                   | 2.5     | 5       | 14,5    | 12       | 25      | 60      | 2 |                  | 1        | o | 50811815     |
| 38                   | 2.5     | 6       | 18      | 12       | 25      | 63      | 2 |                  | 1        | o | 50811816     |

## HW 1593 V-groeffrezen Z=3

|         |          |         |            |   |    |      |     |
|---------|----------|---------|------------|---|----|------|-----|
| Product | Tekening | Machine | Toepassing | Uitvoering  |    |      |     |
|         |          |         |            | <table border="1"> <tr><td>HW</td></tr> <tr><td>TC05</td></tr> <tr><td>MAN</td></tr> </table> | HW | TC05 | MAN |
| HW      |          |         |            |   |    |      |     |
| TC05    |          |         |            |   |    |      |     |
| MAN     |          |         |            |   |    |      |     |

|  |  |           |  |
|--|--|-----------|--|
| Machine / gebruiksaanwijzing   | Uitvoering   | Voordelen | Informatie - Tip   |
| <ul style="list-style-type: none"> <li>Handbovenfrezers</li> <li>CNC-machines</li> <li>Voor het frezen van V-groeven, siergroeven, teksten en het afschuiven van hardhout, hout en plaatmateriaal op basis van hout</li> </ul> | <ul style="list-style-type: none"> <li>VHW-frezen met 3 HW-messen</li> <li>Rechtsloop</li> <li>Handmatige aanvoer</li> </ul> |           | <ul style="list-style-type: none"> <li>Frezen met een hoek van 90°, óók te gebruiken voor het verzinken van boorgaten</li> </ul> |



| Producteigenschappen |         |          |         |       |         |   | Bestelinformatie |          |   |              |
|----------------------|---------|----------|---------|-------|---------|---|------------------|----------|---|--------------|
| Ø D [mm]             | L2 [mm] | Ø d [mm] | L3 [mm] | ∠ [°] | L1 [mm] | Z |                  | VE [St.] | V | Bestelnummer |
| 14                   | 16,5    | 12       | 25      | 60    | 62.5    | 3 |                  | 1        | o | 50811812     |
| 14                   | 12,5    | 12       | 25      | 90    | 62.5    | 3 |                  | 1        | o | 50811813     |

# HW 1523 Afrond-fase-freesset Z=2

Sets in houten koffertje

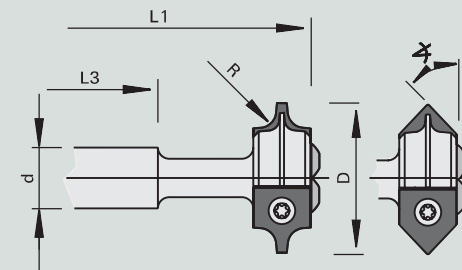
Product Tekening Machine Toepassing Uitvoering





HW  
TC05

MEC

| Machine / gebruiksaanwijzing  | Uitvoering  | Voordelen | Informatie - Tip   |
|---|---|-----------|--|
| <ul style="list-style-type: none"> <li>• CNC-machines</li> <li>• Voor het aan één of beide zijden afronden en afschuinen van massief hout en plaatwerk op basis van hout</li> </ul> | <ul style="list-style-type: none"> <li>• Body met 2 HW-omkeermessen</li> <li>• Rechtsloop</li> <li>• Mechanische aanvoer</li> </ul> |           | <ul style="list-style-type: none"> <li>• In dezelfde body kunnen afrondmessen met verschillende radii of 45°-fasemessen worden gebruikt</li> </ul> |



| Producteigenschappen  |           |         |          |         |         |   | Bestelinformatie |   |          |   |              |
|---|-----------|---------|----------|---------|---------|---|------------------|---|----------|---|--------------|
|   | Ø D1 [mm] | L2 [mm] | Ø d [mm] | L3 [mm] | L1 [mm] | Z | Type             |    | VE [St.] | V | Bestelnummer |
| 1 body maat 1<br>Afrondmessen R2/R3/R4/R5, steeds 2 van elk<br>2 fasemessen 45°   | 27        | 6       | 16       | 60      | 100     | 2 | Set 1            |    | 1        | o | 50811820     |
| 1 body maat 2<br>Afrondmessen R6/R8/R10/R12, steeds 2 van elk<br>2 fasemessen 45° | 47.8      | 9       | 20       | 55      | 120     | 2 | Set 2            |  | 1        | o | 50811821     |
| Omkeermessen  |           |         | B [mm]   | H [mm]  | S [mm]  |   | Snijmateriaal    |   | VE [St.] | V | Bestelnummer |
| Afrondmes   | R= 2 mm   |         | 15       | 18      | 2.0     |   | TC05             |   | 6        | o | 50811822     |
| Afrondmes   | R= 3 mm   |         | 15       | 18      | 2.0     |   | TC05             |   | 6        | o | 50811823     |
| Afrondmes   | R= 4 mm   |         | 15       | 18      | 2.0     |   | TC05             |   | 6        | o | 50811824     |
| Afrondmes   | R= 5 mm   |         | 15       | 18      | 2.0     |   | TC05             |   | 6        | o | 50811825     |
| Fasemes   | Fase 45°  |         | 15       | 18      | 2.0     |   | TC05             |   | 6        | o | 50811826     |
| Afrondmes   | R= 6 mm   |         | 30       | 25      | 2.0     |   | TC05             |   | 6        | o | 50811827     |
| Afrondmes   | R= 8 mm   |         | 30       | 25      | 2.0     |   | TC05             |   | 6        | o | 50811828     |
| Afrondmes   | R= 10 mm  |         | 30       | 25      | 2.0     |   | TC05             |   | 6        | o | 50811829     |
| Afrondmes   | R= 12 mm  |         | 30       | 25      | 2.0     |   | TC05             |   | 6        | o | 50811830     |
| Fasemes   | Fase 45°  |         | 30       | 25      | 2.0     |   | TC05             |   | 6        | o | 50811831     |

# HW 1524 Leuningfrees

Z=2+2

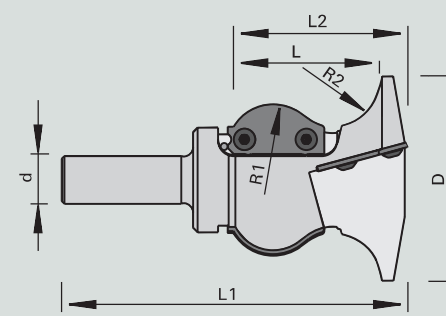
Product Tekening Machine Toepassing Uitvoering



HW  
TCw05

MEC

- |   |  |                  |                         |
|---|--|------------------|-------------------------|
| <b>Machine / gebruiksaanwijzing</b><br><ul style="list-style-type: none"> <li>• CNC-machines</li> <li>• Voor het profileren van leuningen voor trappen en leuning van massief hout</li> </ul> | <b>Uitvoering</b><br><ul style="list-style-type: none"> <li>• Body met 2+2 HW-omkeermessen</li> <li>• Met ashoek</li> <li>• Omvang- en ondersnijdend</li> <li>• Mechanische aanvoer</li> </ul> | <b>Voordelen</b> | <b>Informatie - Tip</b> |
|---|--|------------------|-------------------------|

**Producteigenschappen** **Bestelinformatie**



| Profiel | Ø D [mm] | L2 [mm] | Ø d [mm] | L3 [mm] | L1 [mm] | Z   |  |  | VE [St.] | V | Bestelnummer |
|---------|----------|---------|----------|---------|---------|-----|--|--|----------|---|--------------|
| 1       | 90       | 76      | 20       | 62      | 145     | 2+2 |  |  |          | 1 | o 50811832   |
| 2       | 90       | 76      | 20       | 59      | 145     | 2+2 |  |  |          | 1 | o 50811833   |
| 3       | 90       | 76      | 20       | 63      | 145     | 2+2 |  |  |          | 1 | o 50811834   |

| Omkeermessen               | Profiel | B [mm] | H [mm] | S [mm] | Snijmateriaal | VE [St.] | V | Bestelnummer |
|----------------------------|---------|--------|--------|--------|---------------|----------|---|--------------|
| Profiel-omkeermessen KB450 | 1 oben  | 40     | 25     | 2.0    | TCw05         | 2        | o | 50811835     |
| Profiel-omkeermessen KB374 | 1 unten | 40     | 50     | 2.0    | TCw05         | 2        | o | 50811836     |
| Profiel-omkeermessen KB450 | 2 oben  | 40     | 50     | 2.0    | TCw05         | 2        | o | 50811837     |
| Profiel-omkeermessen KB374 | 2 unten | 40     | 25     | 2.0    | TCw05         | 2        | o | 50811838     |
| Profiel-omkeermessen KB450 | 3 oben  | 40     | 25     | 2.0    | TCw05         | 2        | o | 50811839     |
| Profiel-omkeermessen KB374 | 3 unten | 40     | 50     | 2.0    | TCw05         | 2        | o | 50811840     |

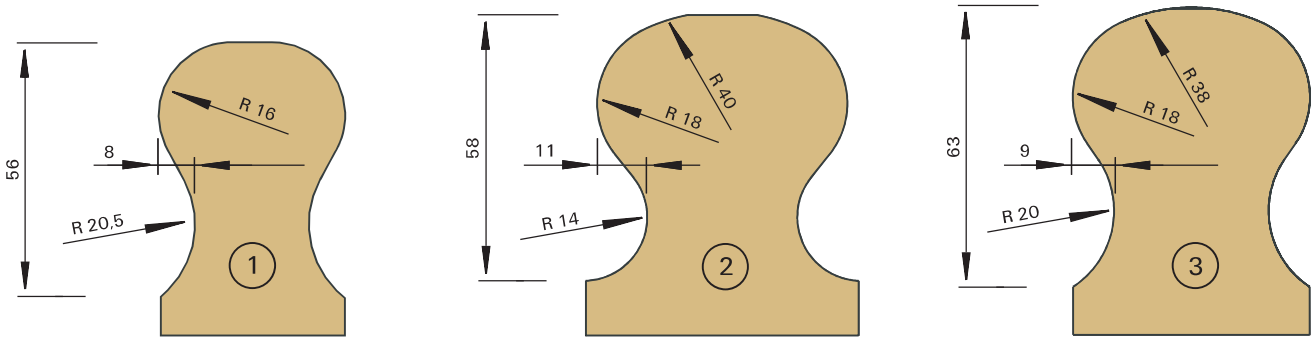

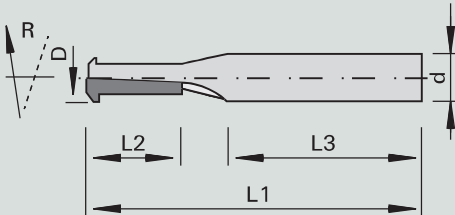

## HW 3512 Profiel-groeffrees HW - voor Lamello Clamex P®

| Product   | Tekening   | Machine   | Toepassing  | Uitvoering |
|---|--|---|---|------------|
|  |  |  |  | <b>MEC</b> |

| Machine / gebruiksaanwijzing   | Uitvoering  | Voordelen   | Informatie - Tip   |
|--|---|---|--|
| <ul style="list-style-type: none"> <li>• 5-assige CNC-machines</li> <li>• Voor het infrezen van Lamello Clamex P® profielgroeven</li> <li>• Speciaal voor verder naar binnen liggende bewerkingen aan de bovenkant van het plaatwerk, als deze niet te realiseren zijn met standaard Lamello Clamex P®-boren op haakse aggregaten</li> </ul> | <ul style="list-style-type: none"> <li>• Met HW belegd</li> <li>• Wegwerpgereedschap</li> </ul> | <ul style="list-style-type: none"> <li>• Probleemoplossing bij ruimtegebrek met haakse aggregaten (opzetten van de onderzijde van het aggregaat bij gebruik van boorgereedschap met een diameter van 100,4 mm)</li> </ul> | <ul style="list-style-type: none"> <li>• Afhankelijk van de staat van het werkstuk is voorfrezen met een ruwfrees VHW met negatieve schroefdraad zinvol (bij deklagen waarbij een groot risico op inscheuren bestaat) of vermindert de snijdruk bij het profielgroeffrezen.</li> </ul> |

| Producteigenschappen |         |          |         |         |   | Bestelinformatie  |   |               |
|----------------------|---------|----------|---------|---------|---|---|---|---------------|
| Ø D [mm]             | L2 [mm] | Ø d [mm] | L3 [mm] | L1 [mm] | Z | VE [St.]  | V | Bestelnr. [L] |
| 10                   | 20      | 10       | 40      | 70      | 1 |  | 1 | 50811810      |

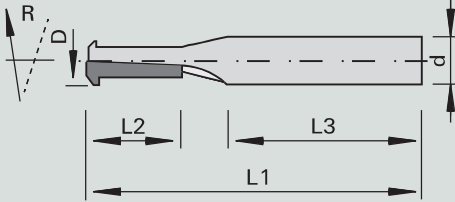
## VHW 3519 Profiel-groeffrees VHW - voor Lamello Clamex P®

| Product | Tekening   | Machine   | Toepassing  | Uitvoering   |
|---------|--|---|---|--|
|         |  |  |  | <b>LONG LIFE</b><br><br><b>VHW</b><br><br><b>MEC</b> |

| Machine / gebruiksaanwijzing   | Uitvoering  | Voordelen   | Informatie - Tip |
|--|---|---|------------------|
| <ul style="list-style-type: none"> <li>• 5-assige CNC-machines</li> <li>• Voor het infrezen van Lamello Clamex P® profielgroeven</li> <li>• Speciaal voor verder naar binnen liggende bewerkingen aan de bovenkant van het plaatwerk, als deze niet te realiseren zijn met standaard Lamello Clamex P®-boren op haakse aggregaten</li> </ul> | <ul style="list-style-type: none"> <li>• VHW massief</li> <li>• Spiraaluitvoering Z=2</li> <li>• Topcoating TC 104</li> <li>• Wegwerpgereedschap</li> <li>• Niet naslijpbaar</li> </ul> | <ul style="list-style-type: none"> <li>• Hoge starheid = weinig trilling ook bij probleemmateriaal</li> <li>• Geringe snijdruk en goede snijkwaliteit door spiraalvorm</li> <li>• Harde coating met extra laag wrijvingscoëfficiënt voor langere standtijd</li> </ul> |                  |

| Producteigenschappen |         |          |         |         |   | Bestelinformatie  |   |               |
|----------------------|---------|----------|---------|---------|---|---|---|---------------|
| Ø D [mm]             | L2 [mm] | Ø d [mm] | L3 [mm] | L1 [mm] | Z | VE [St.]  | V | Bestelnr. [L] |
| 9.8                  | 23      | 12       | 36      | 80      | 2 |  | 1 | 58186879      |



## DP 3518 Profiel-groeffrees DP - voor Lamello Clamex P®

Product



Tekening

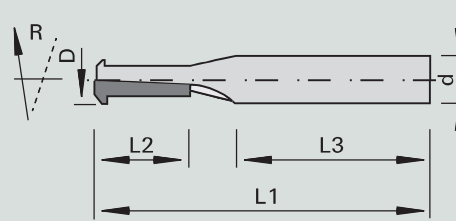

Machine



Toepassing



Uitvoering

MEC

Machine / gebruiksaanwijzing

- 5-assige CNC-machines
- Voor het infrezen van Lamello Clamex P® profielgroeven
- Speciaal voor verder naar binnen liggende bewerkingen aan de bovenkant van het plaatwerk, als deze niet te realiseren zijn met standaard Lamello Clamex P®-boren op haakse aggregaten

Uitvoering

- DP-belegd
- Wegwerpgereedschap

Voordelen

- Probleemoplossing bij ruimtegebrek met haakse aggregaten (opzetten van de onderzijde van het aggregaat bij gebruik van boorgereedschap met een diameter van 100,4 mm)

Informatie - Tip

- Afhankelijk van de staat van het werkstuk is voorfrezen met een ruwfrees VHW met negatieve schroefdraad zinvol (bij deklagen waarbij een groot risico op inscheuren bestaat) of vermindert de snijdruk bij het profielgroeffrezen.

Producteigenschappen

Bestelinformatie

| Ø D [mm] | L2 [mm] | Ø d [mm] | L3 [mm] | L1 [mm] | Z |  |  | VE [St.] | V | Bestelnr. [L]        |
|----------|---------|----------|---------|---------|---|--|--|----------|---|----------------------|
| 10       | 20      | 12       | 40      | 70      | 1 |  |  | 1        |   | 58185703 <b>NEUW</b> |



# BOOR

## Inhoud

Doorgangsboor

4-1

Drevelboor

4-5

Cilinderkopboor

4-11

Verzinker





4-13

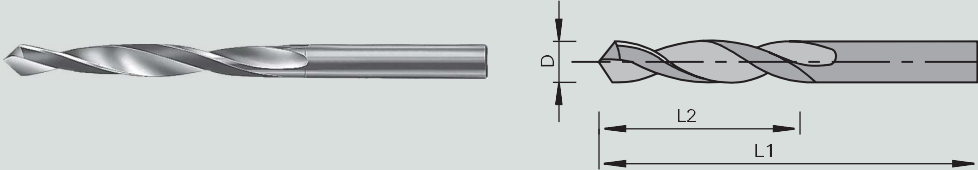

# VHW 2010 Spiraalboor

Product Tekening Machine Toepassing Uitvoering



## Machine / gebruiksaanwijzing

- Handboormachines
- Boorautomaten
- CNC-bewerkingscentra
- Voor het boren van gaten en deuvlgaten in massief hout en plaatmateriaal op basis van hout

## Uitvoering

- 2 dakvormsnedes
- Uitvoering in volhardmetaal
- Snij- $\emptyset$  = schacht  $\emptyset$
- Tophoek 120°

## Voordelen

- Grote aanvoer mogelijk
- Grote naslijpzone

## Informatie - Tip

- Gereedschaphouder: spantang-opname, booropname

## Producteigenschappen

## Bestelinformatie

| $\emptyset$ D [mm] | L2 [mm] | L1 [mm] |  |  |  |  |  | VE [St.] | V | Bestelnr. [L] | V | Bestelnr. [R] |
|--------------------|---------|---------|--|--|--|--|--|----------|---|---------------|---|---------------|
| 2.0                | 25      | 50      |  |  |  |  |  | 1        |   | 50600740      |   | 50600741      |
| 2.5                | 27      | 55      |  |  |  |  |  | 1        |   | 50600742      |   | 50600743      |
| 3.0                | 27      | 55      |  |  |  |  |  | 1        |   | 50600744      |   | 50600745      |
| 3.5                | 27      | 52      |  |  |  |  |  | 1        |   | 50600748      |   | 50600749      |
| 4.0                | 27      | 55      |  |  |  |  |  | 1        |   | 50600750      |   | 50600751      |
| 5.0                | 28      | 60      |  |  |  |  |  | 1        |   | 50600752      |   | 50600753      |

# HW 2020 Doorgangsboor

Product

Tekening

Machine

Toepassing

Uitvoering

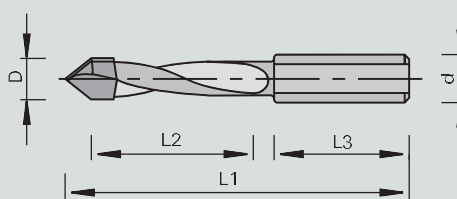

Machine / gebruiksaanwijzing

- Handboormachines
- Boorautomaten
- CNC-bewerkingscentra
- Voor het boren van gaten in massief hout en plaatmateriaal op basis van hout

Uitvoering

- 2 dakvormsnedes van 60 graden
- Met HW belegd
- Cilindrische schacht met spanvlakken
- Spiraal zonder ruggeleiding

Voordelen

Informatie - Tip

- Instelschroef bestelnummer 001600 M5x10 DIN 551 voor nauwkeurige lengte-instelling inbegrepen
- Instelschroef bestelnummer 186017 M5 x 11,5 voor Weeke snelspanboorhouder moet afzonderlijk besteld worden
- Gereedschaphouder: combi-opspanning, snelwisselopspanning

Producteigenschappen

Bestelinformatie

| Ø D [mm] | L2 [mm] | Ø d [mm] | L3 [mm] | L1 [mm] |  |  |  |  | VE [St.] | V | Bestelnr. [L] | V | Bestelnr. [R] |
|----------|---------|----------|---------|---------|--|--|--|--|----------|---|---------------|---|---------------|
| 5.0      | 25      | 10       | 25      | 57.5    |  |  |  |  | 1        |   | 50600132      |   | 50600133      |
| 6.0      | 25      | 10       | 25      | 57.5    |  |  |  |  | 1        |   | 50600144      |   | 50600145      |
| 8.0      | 22      | 10       | 25      | 57.5    |  |  |  |  | 1        |   | 50600134      |   | 50600135      |
| 5.0      | 35      | 10       | 25      | 70      |  |  |  |  | 1        |   | 50600136      |   | 50600137      |
| 6.0      | 35      | 10       | 25      | 70      |  |  |  |  | 1        |   | 50600318      |   | 50600319      |
| 8.0      | 35      | 10       | 25      | 70      |  |  |  |  | 1        |   | 50600138      |   | 50600139      |
| 5.0      | 45      | 10       | 25      | 77      |  |  |  |  | 1        |   | 50600324      |   | 50600325      |
| 8.0      | 43      | 10       | 25      | 77      |  |  |  |  | 1        |   | 50600326      |   | 50600327      |

## HW 2021 Doorgangsboor

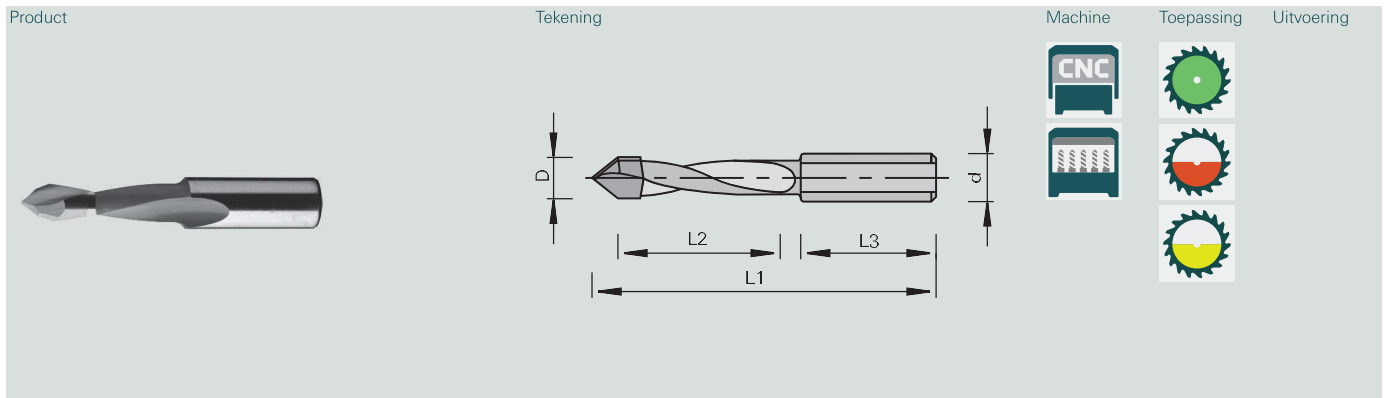

| Machine / gebruiksaanwijzing  | Uitvoering   | Voordelen  | Informatie - Tip  |
|---|--|--|---|
| <ul style="list-style-type: none"> <li>• Handboormachines</li> <li>• Boorautomaten</li> <li>• CNC-bewerkingscentra</li> <li>• Voor het braamvrij boren van gaten in massief hout en plaatmateriaal op basis van hout</li> </ul> | <ul style="list-style-type: none"> <li>• Speciale snijgeometrie</li> <li>• Hardmetaalboorpunt van superfijnkorrelig materiaal</li> </ul> | <ul style="list-style-type: none"> <li>• Braamvrije gatranden door speciale snijgeometrie</li> <li>• Lange standtijden door hardmetaal boorpunt</li> <li>• Hoge betrouwbaarheid van de bewerking door lange constante kwaliteit van de boringen</li> </ul> | <ul style="list-style-type: none"> <li>• Instelschroef bestelnummer 001600 M5x10 DIN 55 1 voor nauwkeurige lengte-instelling inbegrepen</li> <li>• Instelschroef bestelnummer 186017 M5 x 11,5 voor Weeke snelspanboorhouder moet afzonderlijk besteld worden</li> <li>• Gereedschaphouder: combi-opspanning, snelwisselopspanning</li> </ul> |

| Producteigenschappen |         |          |         |         | Bestelinformatie |   |               |   |               |
|----------------------|---------|----------|---------|---------|------------------|---|---------------|---|---------------|
| Ø D [mm]             | L2 [mm] | Ø d [mm] | L3 [mm] | L1 [mm] | VE [St.]         | V | Bestelnr. [L] | V | Bestelnr. [R] |
| 5.0                  | 27      | 10       | 26      | 57.5    | 1                |   | 50600370      |   | 50600371      |
| 5.0                  | 35      | 10       | 26      | 70      | 1                |   | 50600372      |   | 50600373      |
| 8.0                  | 35      | 10       | 26      | 70      | 1                |   | 50600374      |   | 50600375      |
| 10.0                 | 35      | 10       | 26      | 70      | 1                |   | 50183692      |   | 50183693      |

# VHW 2022 Doorgangsboor

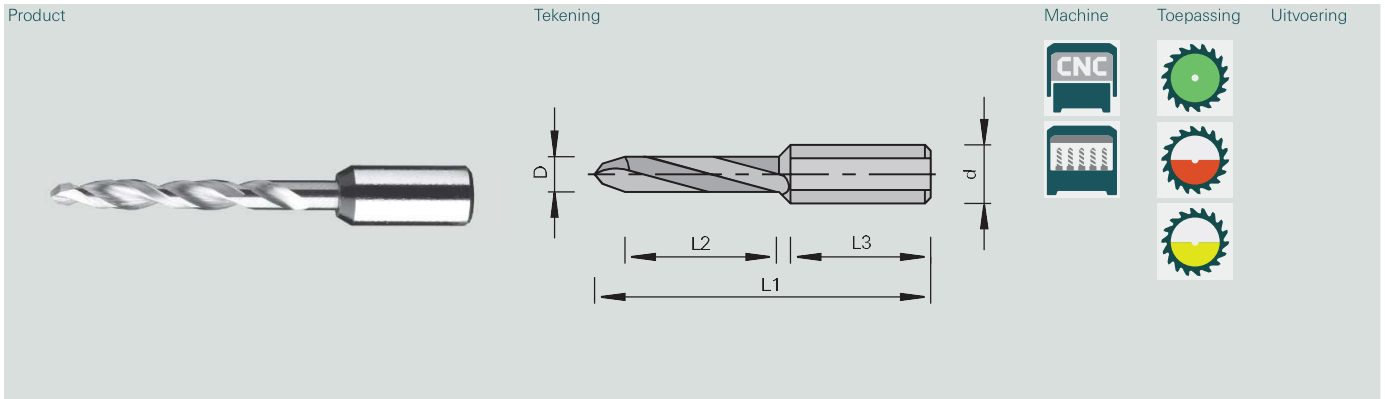

|   |   |  |  |
|---|---|--|--|
| <p>Machine / gebruiksaanwijzing</p> <ul style="list-style-type: none"> <li>• Handboormachines</li> <li>• Boorautomaten</li> <li>• CNC-bewerkingscentra</li> <li>• Voor het braamvrij boren van gaten in massief hout en plaatmateriaal op basis van hout</li> </ul> | <p>Uitvoering</p> <ul style="list-style-type: none"> <li>• Speciale snijgeometrie</li> <li>• Boordeel van fijnkorrelig volhardmetaal</li> </ul> | <p>Voordelen</p> <ul style="list-style-type: none"> <li>• braamvrije boorgatranden door speciale snijgeometrie</li> <li>• Grote aanvoer en tot 6-voudige standtijd vergeleken met standaarddoorgangsboren door uitvoering in volhardmetaal</li> <li>• Hoge betrouwbaarheid van de bewerking door lange constante kwaliteit van de gaten</li> </ul> | <p>Informatie - Tip</p> <ul style="list-style-type: none"> <li>• Instelschroef bestelnummer 00 1600 M5x10 DIN 55 1 inbegrepen</li> <li>• Doorgangsboren met schachtlengte L3= 22,0mm (niet voor Weeke instelschroef te gebruiken)</li> <li>• Instelschroef bestelnummer 186017 M5 x 11,5 voor Weeke moet afzonderlijk besteld worden</li> <li>• Gereedschaphouder: combi-opspanning, snelwisselopspanning</li> </ul> |
|---|---|--|--|

| Producteigenschappen |         |          |         |         | Bestelinformatie       |          |   |               |   |               |
|----------------------|---------|----------|---------|---------|------------------------|----------|---|---------------|---|---------------|
| Ø D [mm]             | L2 [mm] | Ø d [mm] | L3 [mm] | L1 [mm] |                        | VE [St.] | V | Bestelnr. [L] | V | Bestelnr. [R] |
| 3.0                  | 27      | 10       | 30      | 70      |                        | 1        |   | 50600588      |   | 50600376      |
| 4.0                  | 35      | 10       | 24      | 70      |                        | 1        |   | 50600451      |   | 50600450      |
| 5.0                  | 35      | 10       | 24      | 70      |                        | 1        |   | 50600590      |   | 50600378      |
| 6.0                  | 35      | 10       | 50      | 100     | Voor Lamello Clamex P® | 1        |   |               |   | 50600380      |
| 8.0                  | 40      | 10       | 22      | 70      |                        | 1        |   | 50600591      |   | 50600379      |

HW

## 2031 Drevelforen

Met ruggeleiding

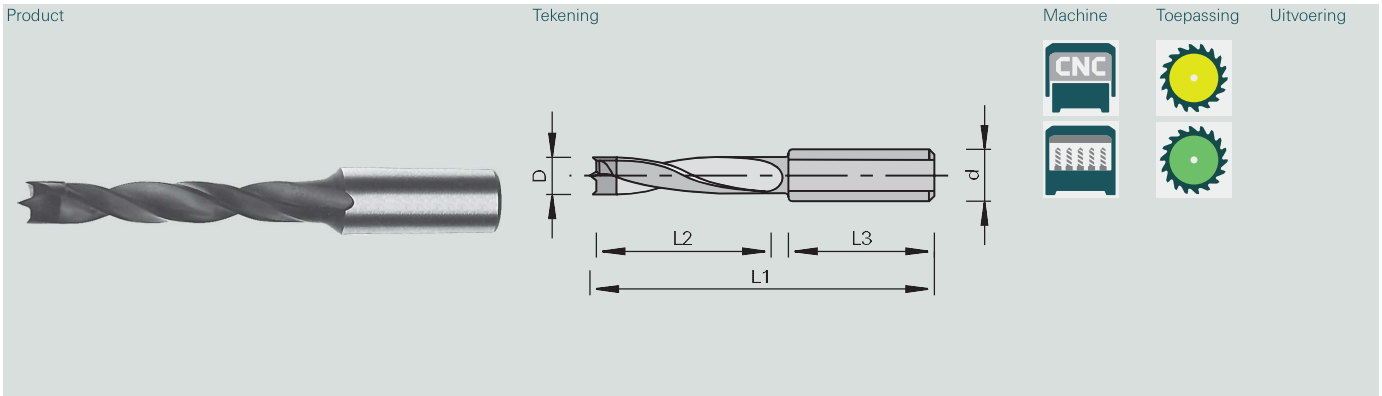

### Machine / gebruiksaanwijzing

- Handboormachines
- Boorautomaten
- CNC-bewerkingscentra
- Voor het braamvrij boren van deuvelgaten in massief hout en plaatmateriaal op basis van hout

### Uitvoering

- 2 negatieve voorsnijders
- Centreerpunt
- Spiraal met ruggeleiding
- Kunststofgecoat
- HW-belegd

### Voordelen

- Braamvrije gatranden door negatieve voorsnijders
- Zuiver spotboren door centreerpunt
- Nette afwerking van het gat, ook bij terughalen door spiraal met ruggeleiding
- Optimale spaanuitworp door kunststofcoating

### Informatie - Tip

- Instelschroef bestelnummer 001600 M5x10 DIN 551 voor nauwkeurige lengte-instelling inbegrepen
- Instelschroef bestelnummer 186017 M5 x 11,5 voor Weeke snelspanboorhouder moet afzonderlijk besteld worden
- Traploze verzinkerbevestiging aan de boorspiraal voor het gelijktijdig verzinken van het gat
- Gereedschaphouder: combi-opname, snelwisselopname

### Producteigenschappen

### Bestelinformatie

| Ø D [mm] | L2 [mm] | Ø d [mm] | L3 [mm] | L1 [mm] |  |  |  |  | VE [St.] | V | Bestelnr. [L] | V | Bestelnr. [R] |
|----------|---------|----------|---------|---------|--|--|--|--|----------|---|---------------|---|---------------|
| 5.0      | 30      | 10       | 19      | 57.5    |  |  |  |  | 1        |   | 50600174      |   | 50600175      |
| 6.0      | 30      | 10       | 20      | 57.5    |  |  |  |  | 1        |   | 50600176      |   | 50600177      |
| 8.0      | 30      | 10       | 20      | 57.5    |  |  |  |  | 1        |   | 50600178      |   | 50600179      |
| 10       | 30      | 10       | 20      | 57.5    |  |  |  |  | 1        |   | 50600180      |   | 50600181      |
| 12       | 30      | 10       | 20      | 57.5    |  |  |  |  | 1        | o | 50600182      |   | 50600183      |



## HW 2032 Drevelboren Zonder ruggeleiding

Product

Tekening

Machine

Toepassing

Uitvoering

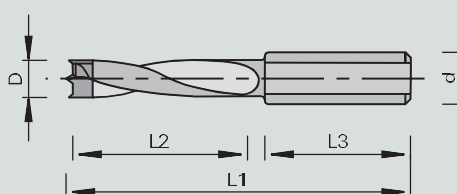

Machine / gebruiksaanwijzing

- Handboormachines
- Boorautomaten
- CNC-bewerkingscentra
- Voor het braamvrij boren van deuvelgaten in massief hout en plaatmateriaal op basis van hout

Uitvoering

- 2 negatieve voorsnijders
- Centreerpunt
- Spiraal zonder ruggeleiding
- Kunststofgecoat
- HW-belegd

Voordelen

- Braamvrije gatranden door negatieve voorsnijders
- Zuiver spotboren door centreerpunt
- Optimale spaanuitwerp door kunststofcoating

Informatie - Tip

- Instelschroef bestelnummer 00 1600 M5x10 DIN 551 voor nauwkeurige lengte-instelling inbegrepen
- Instelschroef bestelnummer 186017 M5 x 11,5 voor Weeke snelspanopname moet afzonderlijk besteld worden
- Gereedschaphouder: combi-opname, snelwisselopname

Producteigenschappen

Bestelinformatie

| Ø D [mm] | L2 [mm] | Ø d [mm] | L3 [mm] | L1 [mm] |  |  |  |  | VE [St.] | V | Bestelnr. [L] | V | Bestelnr. [R] |
|----------|---------|----------|---------|---------|--|--|--|--|----------|---|---------------|---|---------------|
| 4.0      | 27      | 10       | 27      | 57.5    |  |  |  |  | 1        |   | 50600100      |   | 50600101      |
| 5.0      | 27      | 10       | 27      | 57.5    |  |  |  |  | 1        |   | 50600102      |   | 50600103      |
| 6.0      | 27      | 10       | 27      | 57.5    |  |  |  |  | 1        |   | 50600104      |   | 50600105      |
| 8.0      | 27      | 10       | 27      | 57.5    |  |  |  |  | 1        |   | 50600108      |   | 50600109      |
| 8.2      | 27      | 10       | 27      | 57.5    |  |  |  |  | 1        |   | 50600198      |   | 50600199      |
| 9.0      | 27      | 10       | 27      | 57.5    |  |  |  |  | 1        |   | 50600110      |   | 50600111      |
| 10       | 27      | 10       | 27      | 57.5    |  |  |  |  | 1        |   | 50600112      |   | 50600113      |
| 12       | 27      | 10       | 27      | 57.5    |  |  |  |  | 1        |   | 50600114      |   | 50600115      |
| 4.0      | 35      | 10       | 30      | 70      |  |  |  |  | 1        |   | 50600162      |   | 50600163      |
| 5.0      | 35      | 10       | 30      | 70      |  |  |  |  | 1        |   | 50600116      |   | 50600117      |
| 6.0      | 35      | 10       | 30      | 70      |  |  |  |  | 1        |   | 50600118      |   | 50600119      |
| 7.0      | 35      | 10       | 30      | 70      |  |  |  |  | 1        |   | 50600120      |   | 50600121      |
| 8.0      | 35      | 10       | 30      | 70      |  |  |  |  | 1        |   | 50600122      |   | 50600123      |
| 9.0      | 35      | 10       | 30      | 70      |  |  |  |  | 1        |   | 50600124      |   | 50600125      |
| 10       | 35      | 10       | 30      | 70      |  |  |  |  | 1        |   | 50600126      |   | 50600127      |
| 11       | 35      | 10       | 30      | 70      |  |  |  |  | 1        |   | 50600128      |   | 50600129      |
| 12       | 35      | 10       | 30      | 70      |  |  |  |  | 1        |   | 50600130      |   | 50600131      |

HW

**2033 Drevelboren**  
Lange uitvoering met ruggeleiding

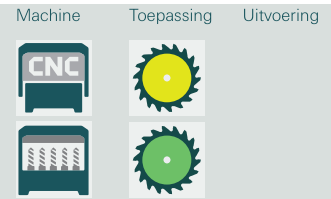
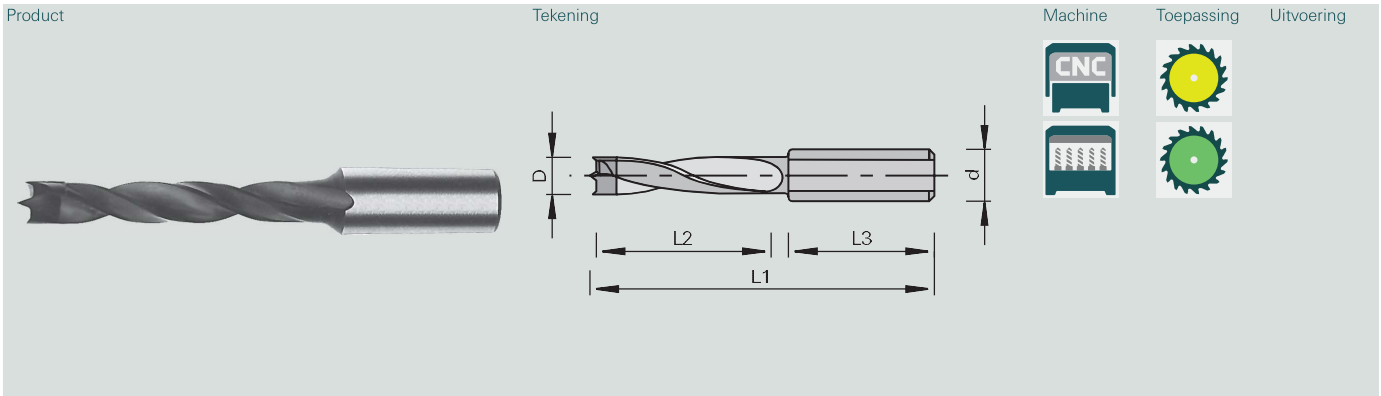

| Machine / gebruiksaanwijzing  | Uitvoering   | Voordelen  | Informatie - Tip   |
|---|--|--|--|
| <ul style="list-style-type: none"> <li>• Handboormachines</li> <li>• Boorautomaten</li> <li>• CNC-bewerkingscentra</li> <li>• Voor het braamvrij boren van deuvelgaten in massief hout en plaatmateriaal op basis van hout</li> </ul> | <ul style="list-style-type: none"> <li>• Lange uitvoering</li> <li>• 2 negatieve voorsnijders</li> <li>• Centreerpunt</li> <li>• Spiraal met ruggeleiding</li> <li>• Kunststofgecoat</li> <li>• HW-belegd</li> </ul> | <ul style="list-style-type: none"> <li>• Diepe gaten mogelijk door lange uitvoering</li> <li>• Braamvrije gatranden door negatieve voorsnijders</li> <li>• Zuiver spotboren door centreerpunt</li> <li>• Nette afwerking van het gat, ook bij terughalen door spiraal met ruggeleiding</li> <li>• Optimale spaanuitworp door kunststofcoating</li> </ul> | <ul style="list-style-type: none"> <li>• Traploze verzinkerbevestiging aan de boorspiraal voor het gelijktijdig verzinken van het gat</li> <li>• Instelschroef bestelnummer 001600 M5x10 DIN 551 voor nauwkeurige lengte-instelling inbegrepen</li> <li>• Instelschroef bestelnummer 186017 M5 x 11,5 voor Weeke snelspanopname moet afzonderlijk besteld worden</li> <li>• Gereedschaphouder: combi-opname, snelwisselopname</li> </ul> |

| Producteigenschappen |         |          |         |         | Bestelinformatie |  |          |   |               |   |               |
|----------------------|---------|----------|---------|---------|------------------|--|----------|---|---------------|---|---------------|
| Ø D [mm]             | L2 [mm] | Ø d [mm] | L3 [mm] | L1 [mm] |                  |  | VE [St.] | V | Bestelnr. [L] | V | Bestelnr. [R] |
| 5.0                  | 50      | 10       | 30      | 85      |                  |  | 1        |   | 50600249      |   | 50600250      |
| 8.0                  | 50      | 10       | 30      | 85      |                  |  | 1        | o | 50600251      |   | 50600252      |
| 10                   | 50      | 10       | 30      | 85      |                  |  | 1        |   | 50600253      |   | 50600254      |
| 7.0                  | 65      | 10       | 30      | 105     |                  |  | 1        |   | 50600255      |   | 50600256      |
| 8.0                  | 65      | 10       | 30      | 105     |                  |  | 1        |   | 50600257      |   | 50600258      |
| 10                   | 65      | 10       | 30      | 105     |                  |  | 1        |   | 50600259      |   | 50600260      |

# HW 2040 Drevelboren

Met speciale snijgeometrie

Product

Tekening

Machine

Toepassing

Uitvoering

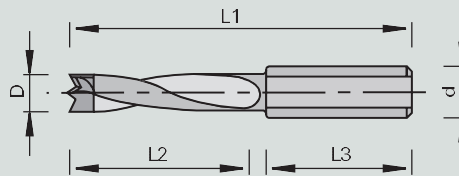

Machine / gebruiksaanwijzing

- Handboormachines
- Boorautomaten
- CNC-bewerkingscentra
- Voor het braamvrij boren van deuvelgaten in massief hout en plaatmateriaal op basis van hout

Uitvoering

- Speciale snijgeometrie
- 2 voorsnijders
- Centreerpunt
- HW-belegd

Voordelen

- Braamvrije gatranden door speciale snijgeometrie met voorsnijders
- Zuiver spotboren door centreerpunt
- Hoge betrouwbaarheid van de bewerking door lange constante kwaliteit van de gaten
- Tot 6-voudige standtijd vergeleken met gebruikelijke deuvelboren door slijtvaste HW-boorpunt

Informatie - Tip

- Instelschroef bestelnummer 00 1600 M5x10 DIN 551 voor nauwkeurige lengte-instelling inbegrepen
- Instelschroef bestelnummer 186017 M5 x 11,5 voor Weeke snelspanopname moet afzonderlijk besteld worden
- Gereedschaphouder: combi-opname, snelwisselopname

Producteigenschappen

Bestelinformatie

| Ø D [mm] | L2 [mm] | Ø d [mm] | L3 [mm] | L1 [mm] |  |  |  |  | VE [St.] | V | Bestelnr. [L] | V | Bestelnr. [R] |
|----------|---------|----------|---------|---------|--|--|--|--|----------|---|---------------|---|---------------|
| 5.0      | 25      | 10       | 27      | 57.5    |  |  |  |  | 1        |   | 50600640      |   | 50600641      |
| 6.0      | 25      | 10       | 27      | 57.5    |  |  |  |  | 1        |   | 50600642      |   | 50600643      |
| 8.0      | 25      | 10       | 27      | 57.5    |  |  |  |  | 1        |   | 50600644      |   | 50600645      |
| 10       | 25      | 10       | 27      | 57.5    |  |  |  |  | 1        |   | 50600646      |   | 50600647      |
| 5.0      | 35      | 10       | 30      | 70      |  |  |  |  | 1        |   | 50600648      |   | 50600649      |
| 6.0      | 35      | 10       | 30      | 70      |  |  |  |  | 1        |   | 50600650      |   | 50600651      |
| 8.0      | 35      | 10       | 30      | 70      |  |  |  |  | 1        |   | 50600652      |   | 50600653      |
| 10       | 35      | 10       | 30      | 70      |  |  |  |  | 1        |   | 50600654      |   | 50600655      |

## VHW 2041 Drevelboren

Met speciale snijgeometrie

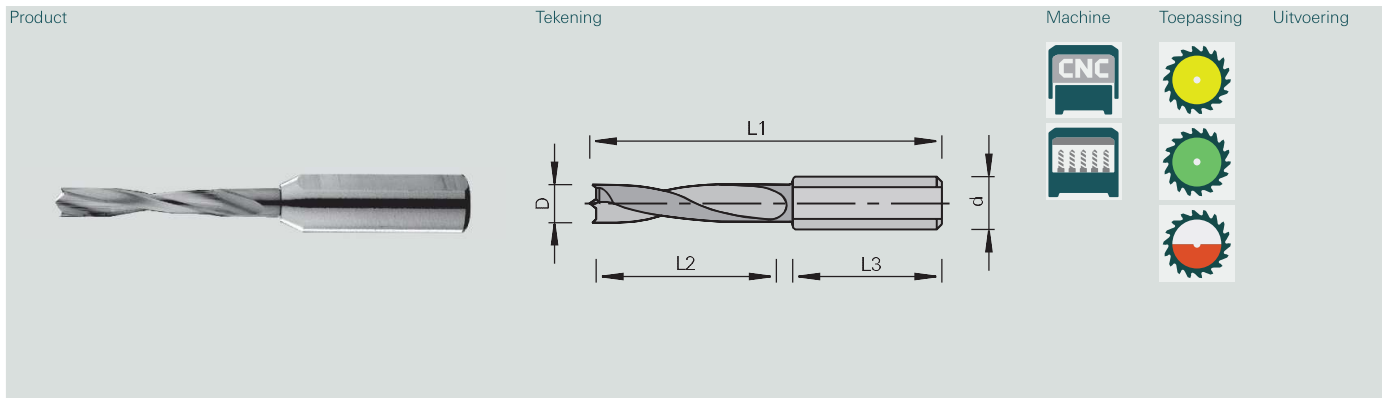

| Machine / gebruiksaanwijzing  | Uitvoering  | Voordelen   | Informatie - Tip   |
|---|---|---|--|
| <ul style="list-style-type: none"> <li>• Handboormachines</li> <li>• Boorautomaten</li> <li>• CNC-bewerkingscentra</li> <li>• Voor het braamvrij boren van deuvclgaten in massief hout en plaatmateriaal op basis van hout</li> </ul> | <ul style="list-style-type: none"> <li>• Speciale snijgeometrie</li> <li>• 2 voorsnijders</li> <li>• Centreerpunt</li> <li>• Boordeel van fijnkorrelig volhardmetaal</li> </ul> | <ul style="list-style-type: none"> <li>• Braamvrije gatranden door speciale snijgeometrie</li> <li>• Zuiver spotboren door centreerpunt</li> <li>• Grote aanvoer en tot 6-voudige standtijd vergeleken met gebruikelijke deuvclboren door uitvoering in volhardmetaal</li> <li>• Hoge betrouwbaarheid van de bewerking door lange constante kwaliteit van de gaten</li> </ul> | <ul style="list-style-type: none"> <li>• Instelschroef bestelnummer 001600 M5x10 DIN 55 1 inbegrepen</li> <li>• Drevelboren met schachtlengte L3= 22,0mm (niet voor Weeke instelschroef te gebruiken)</li> <li>• Instelschroef bestelnummer 186017 M5 x 11,5 voor Weeke moet afzonderlijk besteld worden</li> <li>• Gereedschaphouder: combi-opname, snelwisselopname</li> </ul> |

| Producteigenschappen |         |          |         |         | Bestelinformatie |   |               |   |               |
|----------------------|---------|----------|---------|---------|------------------|---|---------------|---|---------------|
| Ø D [mm]             | L2 [mm] | Ø d [mm] | L3 [mm] | L1 [mm] | VE [St.]         | V | Bestelnr. [L] | V | Bestelnr. [R] |
| 3.0                  | 18      | 10       | 31      | 57.5    | 1                |   | 50600261      |   | 50600262      |
| 4.0                  | 20      | 10       | 29      | 57.5    | 1                | s | 50600453      | s | 50600452      |
| 5.0                  | 22      | 10       | 27      | 57.5    | 1                |   | 50600263      |   | 50600264      |
| 3.0                  | 18      | 10       | 43.5    | 70      | 1                |   | 50600267      |   | 50600268      |
| 4.0                  | 27      | 10       | 34.5    | 70      | 1                |   | 50600455      |   | 50600456      |
| 5.0                  | 30      | 10       | 31.5    | 70      | 1                |   | 50600269      |   | 50600270      |
| 6.0                  | 30      | 10       | 30      | 70      | 1                | o | 50600271      |   | 50600272      |
| 8.0                  | 35      | 10       | 22      | 70      | 1                |   | 50600273      |   | 50600274      |

## VHW 2042 hoogwaardige deugelboor

Product



Tekening

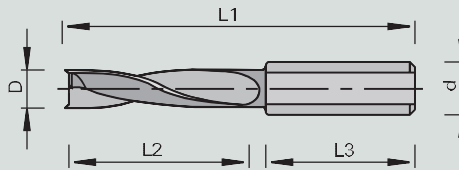

Machine



Toepassing



Uitvoering



Machine / gebruiksaanwijzing

- Vaste boormachines
- Boorautomaten
- CNC-bewerkingscentra
- Voor het boren van gaten en deugelgaten in massief hout en plaatmateriaal op basis van hout

Uitvoering

- Speciale snijgeometrie
- 2 voorsnijders
- Spiraal met ruggeleiding
- Boordeel van volhardmetaal

Voordelen

- Speciale snijgeometrie en voorsnijder voor de minste snijkraft en snijdruk
- Nette afwerking van het gat, ook bij terughalen door spiraal met ruggeleiding
- Hoge aanvoer en grote naslijpzone door boorgedeelte uit volhardmetaal

Informatie - Tip

- Instelschroef bestelnummer 00 1600 M5x10 DIN 551 voor nauwkeurige lengte-instelling inbegrepen
- Instelschroef bestelnummer 186017 M5 x 11,5 voor Weeke snelspanboorhouder moet afzonderlijk besteld worden
- Gereedschaphouder: combi-opname, snelwisselopname
- Patent aangevraagd voor snijgeometrie
- Wijziging van het gepolijste vlak of vermindering van de doorsnede niet mogelijk

Producteigenschappen

Bestelinformatie

| Ø D [mm] | L2 [mm] | Ø d [mm] | L3 [mm] | L1 [mm] |  |  |  |  | VE [St.] | V | Bestelnr. [L] | V | Bestelnr. [R] |
|----------|---------|----------|---------|---------|--|--|--|--|----------|---|---------------|---|---------------|
| 5.0      | 36      | 10       | 30      | 70      |  |  |  |  | 1        |   | 50600691      |   | 50600690      |
| 6.0      | 36      | 10       | 30      | 70      |  |  |  |  | 1        |   | 50600693      |   | 50600692      |
| 8.0      | 36      | 10       | 30      | 70      |  |  |  |  | 1        |   | 50600695      |   | 50600694      |
| 10       | 36      | 10       | 30      | 70      |  |  |  |  | 1        |   | 50600697      |   | 50600696      |

# HW 2050 Cilinderkopboor

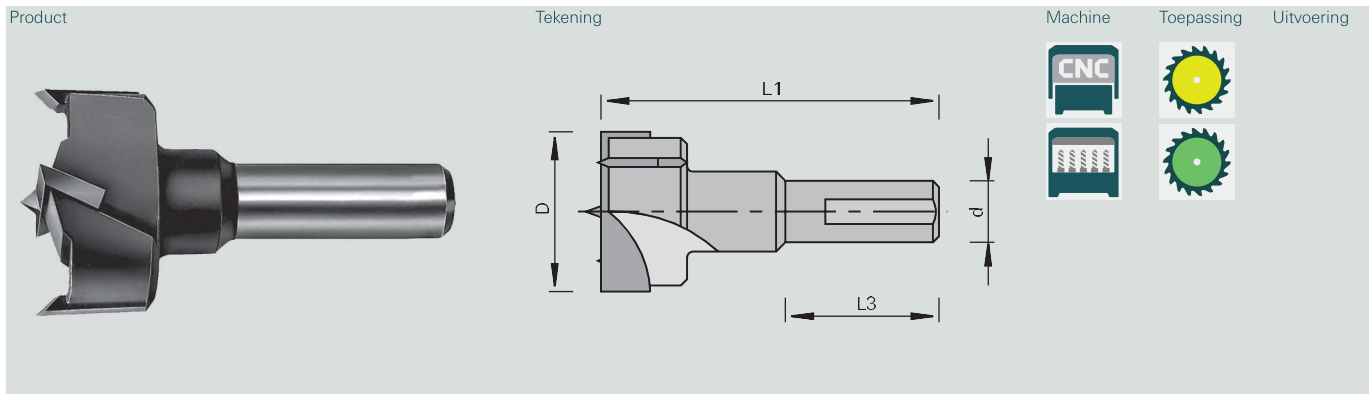

## Machine / gebruiksaanwijzing

- Beslagboormachines
- Boorautomaten
- CNC-bewerkingscentra
- Voor het braamvrij boren van beslaggaten in massief hout en plaatmateriaal op basis van hout

## Uitvoering

- 2 ruimers, 2 voorsnijders en centreerpunt
- HW-belegd

## Voordelen

- Braamvrije gaten door trekkende snede van de voorsnijders

## Informatie - Tip

- Cilindrische schacht met spanvlakken
- Instelschroef bestelnummer 001600 M5x10 DIN 551 voor nauwkeurige lengte-instelling inbegrepen
- Instelschroef bestelnummer 186017 M5 x 11,5 voor Weeke snelspanopname moet afzonderlijk besteld worden
- Gereedschaphouder: combi-opname, snelwisselopname

## Producteigenschappen

## Bestelinformatie

| Ø D [mm] | Ø d [mm] | L3 [mm] | L1 [mm] |  |  |  |  | VE [St.] | V | Bestelnr. [L] | V | Bestelnr. [R] |
|----------|----------|---------|---------|--|--|--|--|----------|---|---------------|---|---------------|
| 15       | 10       | 26      | 57.5    |  |  |  |  | 1        |   | 50600500      |   | 50600501      |
| 16       | 10       | 26      | 57.5    |  |  |  |  | 1        |   | 50600502      |   | 50600503      |
| 18       | 10       | 26      | 57.5    |  |  |  |  | 1        |   | 50600504      |   | 50600505      |
| 20       | 10       | 26      | 57.5    |  |  |  |  | 1        |   | 50600506      |   | 50600507      |
| 22       | 10       | 26      | 57.5    |  |  |  |  | 1        |   | 50600508      |   | 50600509      |
| 25       | 10       | 26      | 57.5    |  |  |  |  | 1        |   | 50600510      |   | 50600511      |
| 26       | 10       | 26      | 57.5    |  |  |  |  | 1        |   | 50600512      |   | 50600513      |
| 30       | 10       | 26      | 57.5    |  |  |  |  | 1        |   | 50600514      |   | 50600515      |
| 35       | 10       | 26      | 57.5    |  |  |  |  | 1        |   | 50600516      |   | 50600517      |
| 40       | 10       | 26      | 57.5    |  |  |  |  | 1        |   | 50600687      |   | 50600688      |
| 15       | 10       | 26      | 70      |  |  |  |  | 1        |   | 50600530      |   | 50600531      |
| 20       | 10       | 26      | 70      |  |  |  |  | 1        |   | 50600532      |   | 50600533      |
| 25       | 10       | 26      | 70      |  |  |  |  | 1        |   | 50600534      |   | 50600535      |
| 26       | 10       | 26      | 70      |  |  |  |  | 1        |   | 50600536      |   | 50600537      |
| 30       | 10       | 26      | 70      |  |  |  |  | 1        |   | 50600538      |   | 50600539      |
| 35       | 10       | 26      | 70      |  |  |  |  | 1        |   | 50600540      |   | 50600541      |

**HW** 2051 Cilinderkopboor  
Lange uitvoering

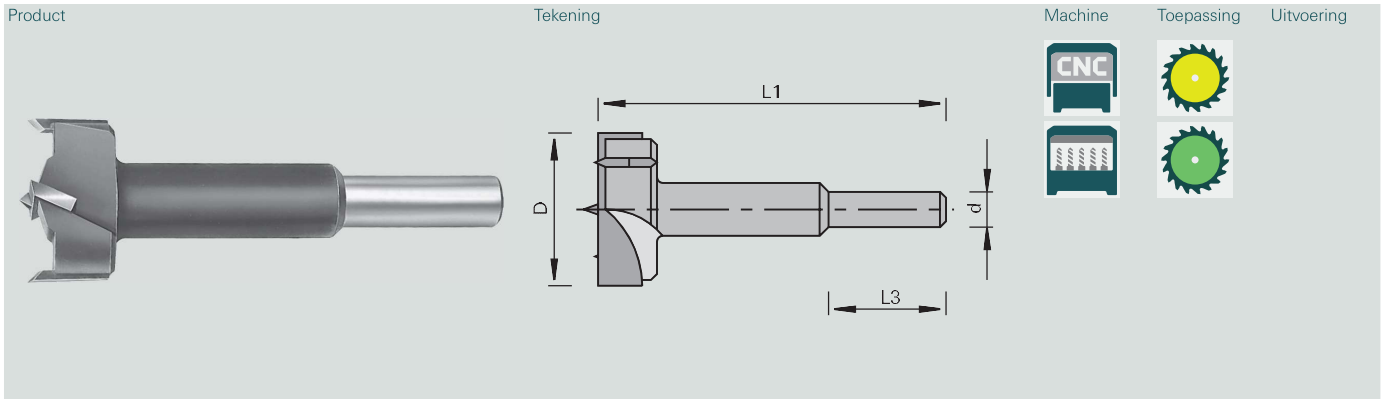

|  |  |  |  |
|--|--|--|--|
| <p>Machine / gebruiksaanwijzing</p> <ul style="list-style-type: none"> <li>• Handboormachines</li> <li>• Voor het braamvrij boren in massief hout en plaatmateriaal op basis van hout</li> </ul> | <p>Uitvoering</p> <ul style="list-style-type: none"> <li>• 2 ruimers, 2 voorsnijders en centreerpunt</li> <li>• HW-belegd</li> <li>• Cilindrische schacht</li> </ul> | <p>Voordelen</p> <ul style="list-style-type: none"> <li>• Braamvrije gaten door trekkende snede van de voorsnijders</li> </ul> | <p>Informatie - Tip</p> <ul style="list-style-type: none"> <li>• Gereedschapshouder: booropname</li> </ul> |
|--|--|--|--|

| Producteigenschappen |          |         |         | Bestelinformatie |          |                |
|----------------------|----------|---------|---------|------------------|----------|----------------|
| Ø D [mm]             | Ø d [mm] | L3 [mm] | L1 [mm] | L                | VE [St.] | V Bestelnummer |
| 15                   | 10       | 60      | 90      | R                | 1        | 50600543       |
| 17                   | 10       | 60      | 90      | R                | 1        | 50600547       |
| 20                   | 10       | 60      | 90      | R                | 1        | 50600553       |
| 25                   | 10       | 60      | 90      | R                | 1        | 50600561       |
| 30                   | 10       | 60      | 90      | R                | 1        | 50600569       |
| 32                   | 10       | 60      | 90      | R                | 1        | 50600571       |
| 35                   | 10       | 60      | 90      | R                | 1        | 50600575       |

## HW 2061 Opsteekverzinker

Voor spiraal- en drevelforen

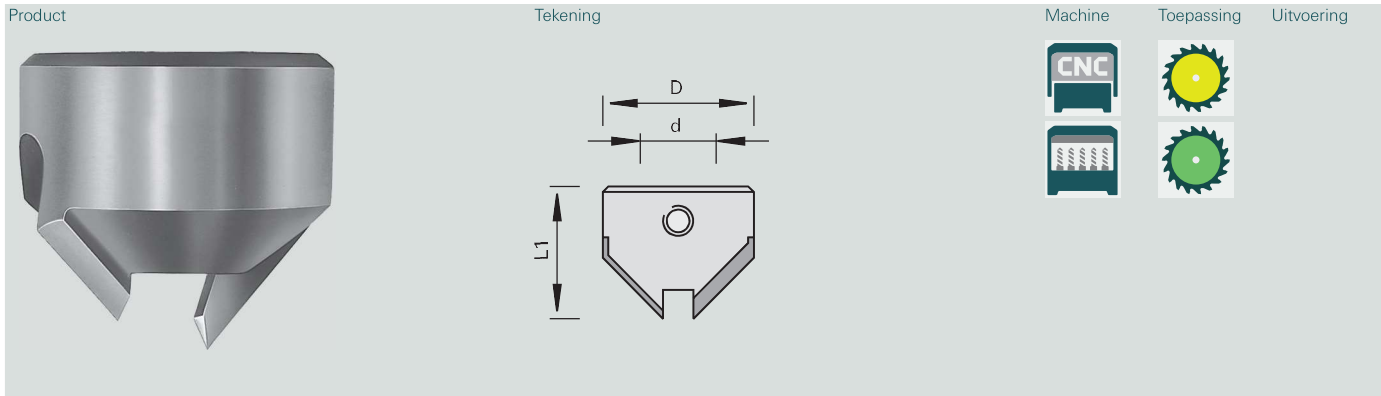

## Machine / gebruiksaanwijzing

- Voor het verzinken van gaten in massief hout en plaatmateriaal op basis van hout
- Voor het braamvrij verzinken onder 45°

## Uitvoering

- HW-belegd

## Voordelen

## Informatie - Tip

- Voor het bevestigen aan spiraalen drevelforen aan de boorspiraal dmv. draadstift
- Traploze instelling van de verzinkdiameter en de boordiepte mogelijk

## Producteigenschappen

## Bestelinformatie

| Ø D [mm]                 | Ø d [mm] | L1 [mm]              |  |  |  |  |  | VE [St.] | V | Bestelnr. [L] | V | Bestelnr. [R] |
|--------------------------|----------|----------------------|--|--|--|--|--|----------|---|---------------|---|---------------|
| 16                       | 5,0      | 15                   |  |  |  |  |  | 1        |   | 50600393      |   | 50600394      |
| 18                       | 8,0      | 15                   |  |  |  |  |  | 1        |   | 50600395      |   | 50600396      |
| Toebehoren               |          | Afmeting [mm]        |  |  |  |  |  | VE [St.] | V | Bestelnummer  |   |               |
| Haakse schroevendraaiers |          | SW3 DIN ISO 2936     |  |  |  |  |  | 1        |   | 009672        |   |               |
| Draadstift               |          | M6x4 DIN EN ISO 4029 |  |  |  |  |  | 10       |   | 167068        |   |               |



## HW 2060 Verzinkboor

Product

Tekening

Machine

Toepassing

Uitvoering

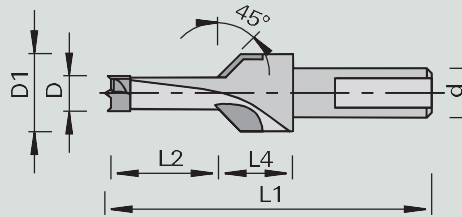

Machine / gebruiksaanwijzing

- Handboormachines
- Boorautomaten
- Voor het boren en gelijktijdig verzinken in massief hout en plaatmateriaal op basis van hout

Uitvoering

- Spiraal PTFE-gecoat
- 2 voorsnijders
- Centreerpunt

Voordelen

- Boren en verzinken in een bewerking
- Zuiver spotboren door centreerpunt

Informatie - Tip

- Instelschroef bestelnummer 001600 M5x10 DIN 551 voor nauwkeurige lengte-instelling inbegrepen
- Instelschroef bestelnummer 186017 M5 x 11,5 voor Weeke snelspanopname moet afzonderlijk besteld worden
- Gereedschaphouder: combi-opname, snelspanopname

Producteigenschappen

Bestelinformatie

| Ø D [mm] | L2 [mm] | Ø D1 [mm] | L4 [mm] | Ø d [mm] | L1 [mm] |  |  |  | VE [St.] | V | Bestelnr. [L] | V | Bestelnr. [R] |
|----------|---------|-----------|---------|----------|---------|--|--|--|----------|---|---------------|---|---------------|
| 8.0      | 12      | 16        | 15      | 10       | 57.5    |  |  |  | 1        |   | 50600389      |   | 50600390      |
| 8.0      | 12      | 16        | 15      | 10       | 70      |  |  |  | 1        |   | 50600391      |   | 50600392      |

## HW 2062 Verzinker

Voor spiraalboor

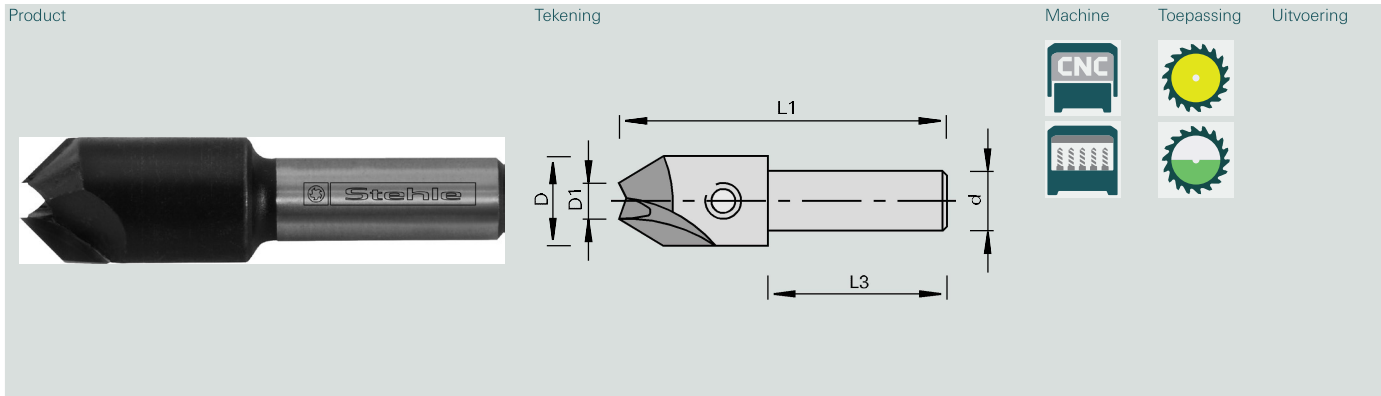

| Machine / gebruiksaanwijzing   | Uitvoering  | Voordelen | Informatie - Tip   |
|--|---|-----------|--|
| <ul style="list-style-type: none"> <li>Voor het verzinken van gaten in massief hout en plaatmateriaal op basis van hout</li> <li>Voor het braamvrij verzinken onder 45°</li> </ul> | <ul style="list-style-type: none"> <li>Met HW belegd</li> </ul> |           | <ul style="list-style-type: none"> <li>Voor het opspannen van spiraalbooren van <math>\varnothing</math> 3 - 6 mm</li> <li>Traploze instelling van de verzinkdiameter en de boordiepte mogelijk</li> </ul> |

| Producteigenschappen |                       |                      |         |         | Bestelinformatie |          |                |
|----------------------|-----------------------|----------------------|---------|---------|------------------|----------|----------------|
| $\varnothing$ D [mm] | $\varnothing$ D1 [mm] | $\varnothing$ d [mm] | L3 [mm] | L1 [mm] | L                | VE [St.] | V Bestelnummer |
| 15                   | 3.0                   | 10                   | 30      | 58      | R                | 1        | 50600397       |
| 15                   | 3.5                   | 10                   | 30      | 58      | R                | 1        | 50600430       |
| 15                   | 4.0                   | 10                   | 30      | 58      | R                | 1        | 50600431       |
| 15                   | 4.5                   | 10                   | 30      | 58      | R                | 1        | 50600381       |
| 15                   | 5.0                   | 10                   | 30      | 58      | R                | 1        | 50600382       |
| Toebehoren           |                       | Afmeting [mm]        |         |         |                  | VE [St.] | V Bestelnummer |
| Draadstift           |                       | M6x6 DIN EN ISO 4029 |         |         |                  | 10       | 180003         |

# OPSPAN SYSTEMEN

## Inhoud

|                |      |
|----------------|------|
| Zaagopnamen    | 5-1  |
| Booropnamen    | 5-5  |
| Spantangen     | 5-9  |
| Hydro opnamen  | 5-16 |
| Reduceerhulzen | 5-17 |
| TRIBOS         | 5-18 |
| Krimpopnamen   | 5-19 |
| Toebehoren     | 5-20 |



## Adapter met cilinderschacht

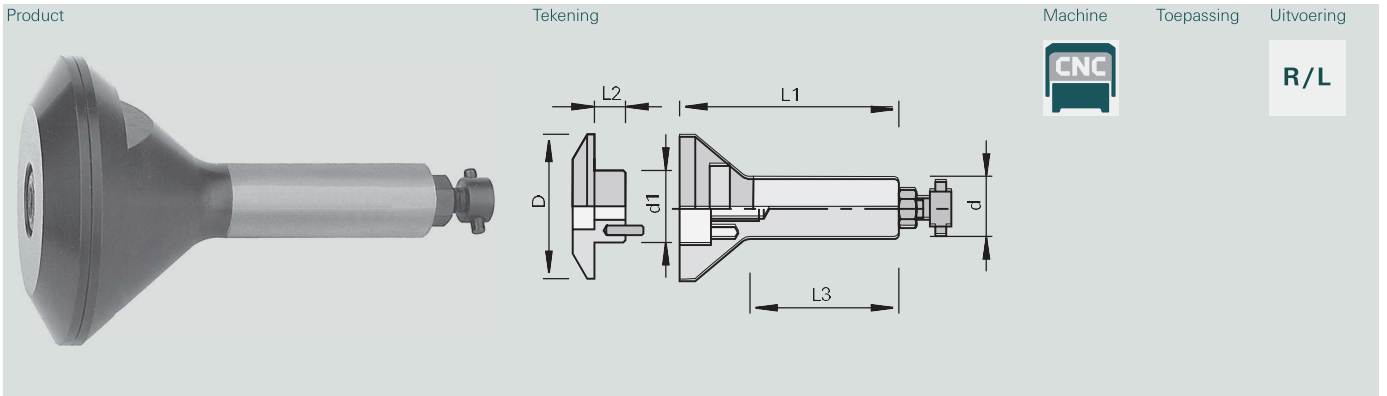

### Machine / gebruiksaanwijzing

- Voor toepassing bij de PS 2000-E en spantangopnamen voor het opspannen van cirkelzaagbladen en groefgereedschap

### Uitvoering

- Verdraaiblokkering door stift

### Voordelen

### Informatie - Tip

- Voor rechts- en linksloop
- Voor PS 2000-E is de lengte-instelschroef bestelnummer 172921 nodig
- Inhoud van de verpakking: Opspandoorn, spanflens, inbusbout en lengte-instelschroef voor ps-Systeem voor;
  - schacht Ø 16 bestelnummer 172115
  - schacht Ø 25 bestelnummer 172113

### Producteigenschappen

### Bestelinformatie

| Ø D [mm] | Ø d [mm] | L2 [mm] | L1 [mm] | L3 [mm] |                                   | VE [St.] | V Bestelnummer |
|----------|----------|---------|---------|---------|-----------------------------------|----------|----------------|
| 60       | 16       | 8,0     | 78      | 43      | Voor dikte zaagstamblad max. 6 mm | 1        | 171394         |
| 60       | 25       | 9,0     | 94      | 55      | Voor dikte zaagstamblad max. 8 mm | 1        | 167826         |

## Adapter met cilinderschacht

Product



Tekening

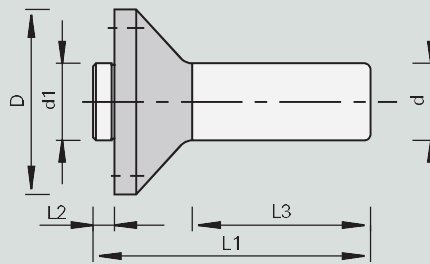

Machine



Toepassing

Uitvoering

R/L

Machine / gebruiksaanwijzing

- Voor toepassing bij de PS 2000-E en spantangopnamen voor het opspannen van cirkelzaagbladen en groefgereedschap

Uitvoering

- Gereedschapbevestiging en verdraaiblokkering via schroefverbinding

Voordelen

Informatie - Tip

- Voor rechts- en linksloop
- Voor PS 2000-E is de lengte-instel-schroef Bestelnr. 172921 nodig
- Spanlengte L2 = 30 en 36 mm voor een- en meerdelige freesgereedschappen
- Spanlengte L2 = 4 en 5 mm voor cirkelzaagbladen en groefgereedschappen
- Leveringsomvang: adapter voor Lamello Clamex P® inclusief 4 kruiskopschroeven, alle andere adapters zonder kruiskopschroeven. Deze afhankelijk van het gebruik in de noodzakelijke lengtes apart bestellen.

Producteigenschappen

Bestelinformatie

| Ø D [mm] | Ø d [mm] | Ø d1 [mm] | L2 [mm] | L1 [mm] | L3 [mm] | NL                |                   | VE [St.] | V | Bestelnummer |
|----------|----------|-----------|---------|---------|---------|-------------------|-------------------|----------|---|--------------|
| 50       | 16       | 22        | 4,0     | 68      | 45      | 4/M5/34 + 4/M4/36 |                   | 1        |   | 184277       |
| 50       | 25       | 22        | 4,0     | 92      | 60      | 4/M5/34 + 4/M4/36 |                   | 1        |   | 184276       |
| 60       | 16       | 30        | 4,0     | 80      | 60      | 4/M6/48           | Lamello Clamex P® | 1        |   | 184304       |
| 60       | 25       | 30        | 4,0     | 90      | 70      | 4/M6/48           | Lamello Clamex P® | 1        |   | 184305       |
| 60       | 25       | 25        | 30      | 111     | 60      | 6/M6/48           |                   | 1        | o | 168814       |
| 60       | 25       | 30        | 36      | 117     | 60      | 6/M6/48           |                   | 1        |   | 168815       |
| 66       | 25       | 30        | 5,0     | 92      | 60      | 4/M5/48           |                   | 1        |   | 171386       |

## CNC combizaagopname HSK 63F

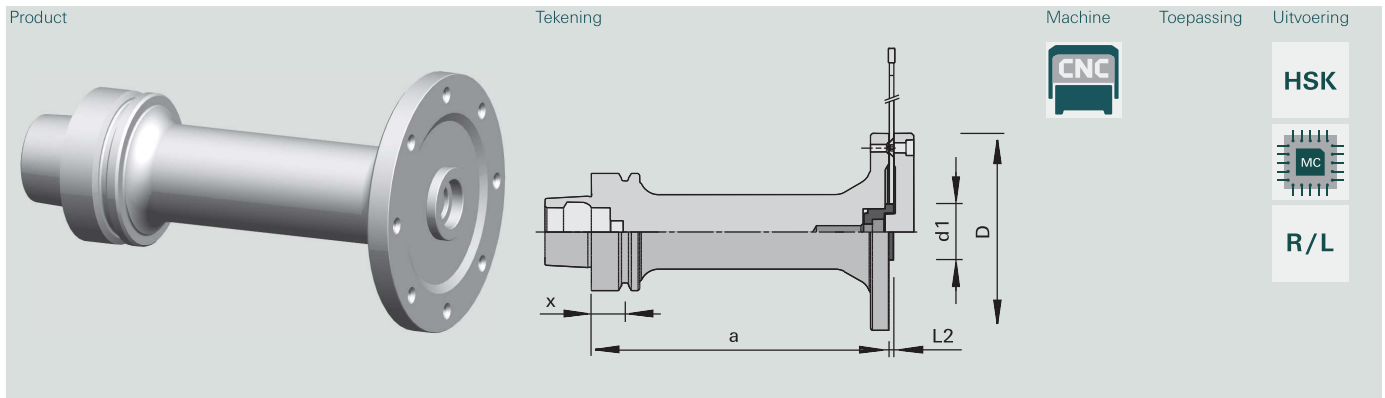

| Machine / gebruiksaanwijzing  | Uitvoering  | Voordelen   | Informatie - Tip   |
|---|---|---|--|
| <ul style="list-style-type: none"> <li>CNC-bewerkingscentra met automatische gereedschapwisselaar</li> <li>Voor de nauwkeurige opspanning van cirkelzaagbladen</li> </ul> | <ul style="list-style-type: none"> <li>Gereedschaphouder DIN 69893 HSK 63 F voor nauwkeurige opspanning op de machine-as</li> </ul> | <ul style="list-style-type: none"> <li>Verwisselbare centreeradapter apart verkrijgbaar, zodat ook cirkelzaagbladen met verschillende asgatdiameters op dezelfde opname gebruikt kunnen worden</li> <li>Cirkelzaagbladmontage naar keuze met of zonder deksel mogelijk</li> <li>Opnames met a-afmeting in verschillende lengtes verkrijgbaar</li> </ul> | <ul style="list-style-type: none"> <li>Voor rechts- en linksloop</li> <li>Fixatie van de zaag rechtstreeks met behulp van kruiskopschroeven of met deksel met behulp van cilinderkopschroeven</li> <li>Bij de levering inbegrepen: deksel, kruiskopschroeven, cilinderkopschroeven en centreeradapter voor gat Ø 30 mm incl. borgring</li> </ul> |

| Producteigenschappen                         |          |                       |         |        |        |         | Bestelinformatie |   |              |
|--|----------|-----------------------|---------|--------|--------|---------|------------------|---|--------------|
| Ø D [mm]                                     | Ø d [mm] | Ø d1 [mm]             | L2 [mm] | a [mm] | x [mm] | NL      | VE [St.]         | V | Bestelnummer |
| 106  | HSK 63F  | 30                    | 2,5     | 40     | 18     | 8/M5/90 | 1                |   | 184835       |
| 106  | HSK 63F  | 30                    | 2,5     | 50     | 18     | 8/M5/90 | 1                |   | 184836       |
| 106  | HSK 63F  | 30                    | 2,5     | 100    | 18     | 8/M5/90 | 1                |   | 184837       |
| 106  | HSK 63F  | 30                    | 2,5     | 130    | 18     | 8/M5/90 | 1                |   | 184838       |
| 106  | HSK 63F  | 30                    | 2,5     | 160    | 18     | 8/M5/90 | 1                |   | 184839       |
| Toebehoren                                   |          | Afmeting [mm]         |         |        |        |         | VE [St.]         | V | Bestelnummer |
| Deksel                                       |          | 106x15x20             |         |        |        |         | 1                |   | 184845       |
| Adapter                                      |          | Ø30                   |         |        |        |         | 1                |   | 184840       |
| Adapter                                      |          | Ø31,75                |         |        |        |         | 1                |   | 184841       |
| Adapter                                      |          | Ø32                   |         |        |        |         | 1                |   | 184842       |
| Adapter                                      |          | Ø35                   |         |        |        |         | 1                |   | 184843       |
| Adapter voor stambladdikte van 2,0 of 2,2 mm |          | Ø30                   |         |        |        |         | 1                |   | 185666       |
| Adapter                                      |          | Ø40                   |         |        |        |         | 1                |   | 184844       |
| Toebehoren                                   |          | Afmeting [mm]         |         |        |        |         | VE [St.]         | V | Bestelnummer |
| Cilinderkopschroeven                         |          | M5x16 DIN EN ISO 4762 |         |        |        |         | 10               |   | 001870       |
| Cilinderkopschroeven voor adapter            |          | M8x12 DIN 7984        |         |        |        |         | 10               |   | 184846       |
| Borgringen                                   |          | 8/13x8,4x0,7          |         |        |        |         | 1                |   | 185497       |
| Kruiskopschroeven                            |          | M5x12 T20             |         |        |        |         | 10               |   | 166709       |

## Zagen-opname HSK 63F

Product



Tekening

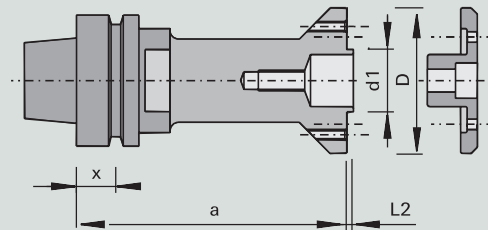

Machine



Toepassing

Uitvoering

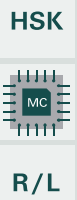

Machine / gebruiksaanwijzing

- CNC-bewerkingscentra met automatische gereedschapwisselaar
- Voor de nauwkeurige opspanning van cirkelzaagbladen en groefzagen

Uitvoering

- Gereedschaphouder DIN 69893 HSK 63 F voor nauwkeurige opspanning op de machine-as



Voordelen

Informatie - Tip

- Voor rechts- en linksloop
- Bevestiging van de zaag direct via verzonken kop-schroef of met deksel 183310 via cilinderkop-schroef
- Inbegrepen:
- Opspanning met verzonken kop-schroeven
- Deksel met cilinderkop-schroeven indien nodig apart bijbestellen

| Producteigenschappen             | Ø d [mm]         | Ø d1 [mm] | L2 [mm] | a [mm] | x [mm] | NL                  | VE [St.] | V Bestelnummer |
|----------------------------------|------------------|-----------|---------|--------|--------|---------------------|----------|----------------|
| 70                               | HSK 63F          | 30        | 1,8     | 70     | 18     | 8/M5/52<br>+ 2/6/42 | 1        | 186083         |
| 70                               | HSK 63F          | 30        | 1,8     | 130    | 18     | 8/M5/52<br>+ 2/6/42 | 1        | 186432         |
| Toebehoren                       | Afmeting [mm]    |           |         |        |        |                     | VE [St.] | V Bestelnummer |
| Deksel met cilinderkop-schroeven | 70x24x8 (2/6/42) |           |         |        |        |                     | 1        | 183310         |
| Toebehoren                       | Afmeting [mm]    |           |         |        |        |                     | VE [St.] | V Bestelnummer |
| Verzonken kopschroeven           | M5x8 T20         |           |         |        |        |                     | 10       | 164005         |

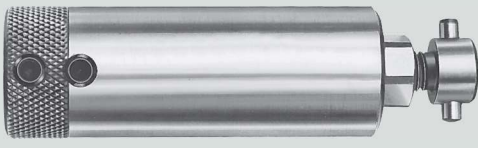
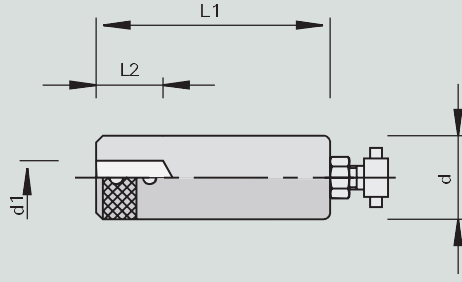
## Adapter met cilinderschacht



|  |  |  |                   |                              |
|--|--|--|-------------------|------------------------------|
| <p>Product</p>  | <p>Tekening</p>  | <p>Machine</p>  | <p>Toepassing</p> | <p>Uitvoering</p> <p>R/L</p> |
|--|--|--|-------------------|------------------------------|

|   |                   |                  |   |
|---|-------------------|------------------|---|
| <p>Machine / gebruiksaanwijzing</p> <ul style="list-style-type: none"> <li>Voor toepassing bij de PS 2000-E voor het opspannen van schachtgereedschap met schachtdiameters van 6-12 mm</li> </ul> | <p>Uitvoering</p> | <p>Voordelen</p> | <p>Informatie - Tip</p> <ul style="list-style-type: none"> <li>De gereedschapschachten moeten zijn voorzien van spanvlakken</li> <li>Voor PS 2000-E is de lengte-instelschroef bestelnummer 172921 nodig</li> <li>Met lengte-instelschroef voor ps-System Ø 16 mm bestelnummer 172115, Ø 25 mm bestelnummer 172113</li> </ul> |
|---|-------------------|------------------|---|

| Producteigenschappen |           |         |         | Bestelinformatie |                |
|----------------------|-----------|---------|---------|------------------|----------------|
| Ø d [mm]             | Ø d1 [mm] | L2 [mm] | L1 [mm] | VE [St.]         | V Bestelnummer |
| 25                   | 6         | 20      | 70      | 1                | 172103         |
| 25                   | 8         | 20      | 70      | 1                | 172104         |
| 25                   | 10        | 20      | 70      | 1                | 172101         |
| 25                   | 12        | 20      | 70      | 1                | 172102         |

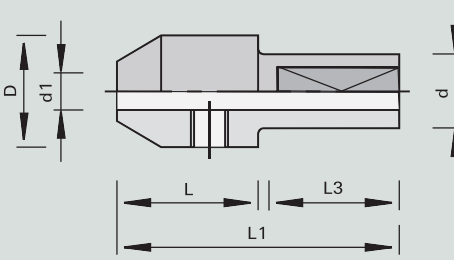

## Boor-adpater

|  |  |  |  |
|--|--|--|--|
| <p>Product</p>  | <p>Tekening</p>  | <p>Machine</p>  | <p>Toepassing</p> <p>Uitvoering</p> <p>R/L</p> |
|--|--|--|--|

|  |  |                  |  |
|--|--|------------------|--|
| <p>Machine / gebruiksaanwijzing</p> <ul style="list-style-type: none"> <li>Voor het opspannen van spiraalboren in combi-opnamen en in Klack-opnamen</li> </ul> | <p>Uitvoering</p> <ul style="list-style-type: none"> <li>Schacht met spanvlakken</li> <li>Schroefdraad M5, zonder schroef</li> </ul> | <p>Voordelen</p> | <p>Informatie - Tip</p> <ul style="list-style-type: none"> <li>Instel- en bevestigingsbout bestelnummer 186017 M5 x 11,5 voor Weeke snelspanboorhouder moet afzonderlijk besteld worden</li> </ul> |
|--|--|------------------|--|

| Producteigenschappen     |        |                      |         |          |         | Bestelinformatie |   |              |
|--------------------------|--------|----------------------|---------|----------|---------|------------------|---|--------------|
| Ø d1 [mm]                | L [mm] | Ø d [mm]             | L3 [mm] | Ø D [mm] | L1 [mm] | VE [St.]         | V | Bestelnummer |
| 2                        | 19     | 10                   | 21      | 15       | 41      | 1                |   | 183275       |
| 2,5                      | 19     | 10                   | 21      | 15       | 41      | 1                |   | 183276       |
| 3                        | 19     | 10                   | 21      | 15       | 41      | 1                |   | 183277       |
| 3,5                      | 19     | 10                   | 21      | 15       | 41      | 1                |   | 183278       |
| 4                        | 19     | 10                   | 21      | 15       | 41      | 1                |   | 183279       |
| 5                        | 19     | 10                   | 21      | 15       | 41      | 1                |   | 183280       |
| Toebehoren               |        | Afmeting [mm]        |         |          |         | VE [St.]         | V | Bestelnummer |
| Draadstift               |        | M6x6 DIN EN ISO 4029 |         |          |         | 10               |   | 180003       |
| Haakse schroevendraaiers |        | SW3 DIN ISO 2936     |         |          |         | 1                |   | 009672       |

## Boor-adpater - Combisysteem

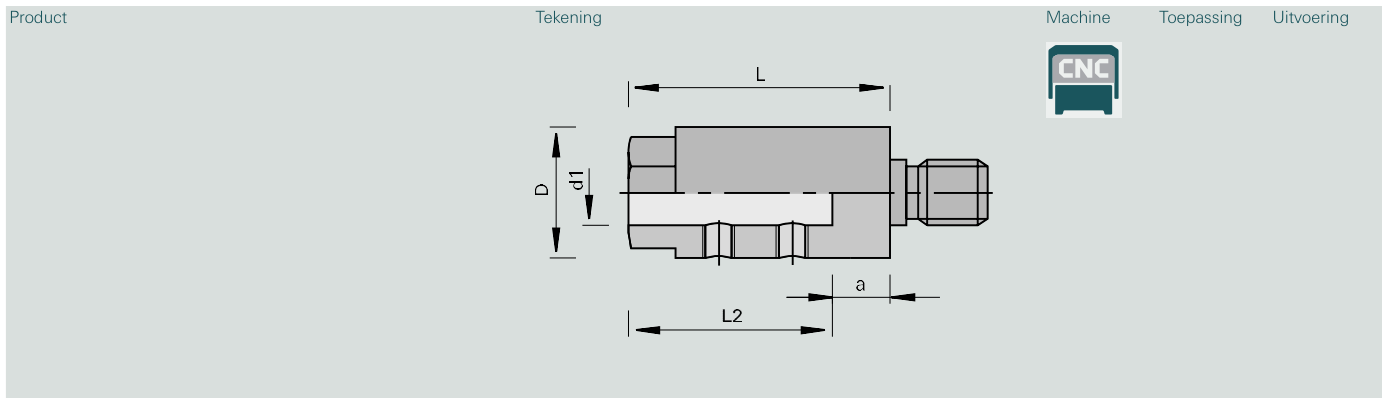

| Machine / gebruiksaanwijzing  | Uitvoering  | Voordelen | Informatie - Tip  |
|---|---|-----------|---|
| <ul style="list-style-type: none"> <li>Voor de opname van boren met een cilindrische schacht en opspanvlak</li> </ul> | <ul style="list-style-type: none"> <li>Met inbusschroeven voor het opspannen van de boor</li> </ul> |           | <ul style="list-style-type: none"> <li>Opnamen met kenmerk 'BSS' zijn compatibel met het boorsnelwisselsysteem</li> <li>Uitvoering en machinetoewijzing zie hoofdstuk 8 - Technische bijlage</li> </ul> |

| Producteigenschappen   |           |         |        |        |                      | Bestelinformatie |   |               |   |               |  |
|------------------------|-----------|---------|--------|--------|----------------------|------------------|---|---------------|---|---------------|--|
| Ø D [mm]               | Ø d1 [mm] | L2 [mm] | L [mm] | a [mm] | Type                 | VE [St.]         | V | Bestelnr. [L] | V | Bestelnr. [R] |  |
| 15                     | 8         | 20      | 22     | 2.0    | D                    | 1                | o | 161282        | o | 161281        |  |
| 15                     | 8         | 20      | 24.5   | 4.5    | A                    | 1                | o | 010683        | o | 010677        |  |
| 15                     | 8         | 20      | 24.5   | 4.5    | B                    | 1                | o | 161285        | o | 161284        |  |
| 15                     | 8         | 20      | 24.5   | 4.5    | C                    | 1                | o | 058412        | o | 058411        |  |
| 15                     | 8         | 20      | 37     | 17     | C                    | 1                |   | 059300        |   | 059299        |  |
| 19                     | 10        | 20      | 24.5   | 4.5    | A                    | 1                |   | 003575        |   | 003574        |  |
| 19                     | 10        | 20      | 24.5   | 4.5    | B                    | 1                |   | 008003        |   | 008002        |  |
| 19                     | 10        | 20      | 24.5   | 4.5    | C                    | 1                |   | 058414        |   | 058413        |  |
| 19                     | 10        | 20      | 25     | 5.0    | D                    | 1                |   | 003571        |   | 003570        |  |
| 19                     | 10        | 20      | 25     | 5.0    |                      | 1                | o | 183055        | o | 183055        |  |
| 19                     | 10        | 20      | 47     | 27     | G                    | 1                |   | 161287        |   | 161286        |  |
| 19                     | 10        | 20      | 29.3   | 9.3    | F                    | 1                |   | 003573        |   | 003572        |  |
| 19                     | 10        | 20      | 28.5   | 8.5    | E                    | 1                | s | 161987        | s | 161283        |  |
| 19                     | 10        | 20      | 37     | 17     | C                    | 1                |   | 161681        |   | 161680        |  |
| 19                     | 10        | 20      | 47     | 27     | D                    | 1                | s | 170372        | s | 170371        |  |
| BSS                    |           |         |        |        |                      | 1                | s | 170372        | s | 170371        |  |
| Toebehoren             |           |         |        |        | Afmeting [mm]        | VE [St.]         | V | Bestelnummer  |   |               |  |
| Draadstift             |           |         |        |        | M6x4 DIN EN ISO 4029 | 10               |   | 167068        |   |               |  |
| Schroefkoppingsstiften |           |         |        |        | M6x5 DIN EN ISO 4029 | 10               |   | 165049        |   |               |  |
| Schroefkoppingsstiften |           |         |        |        | M5x4 DIN EN ISO 4029 | 10               |   | 001608        |   |               |  |

## CNC booropname

Product

Tekening

Machine

Toepassing

Uitvoering



R/L



## Machine / gebruiksaanwijzing

- CNC-bewerkingscentra met automatische gereedschapwisselaar
- Voor het opspannen van boren met cilindrische schacht

## Uitvoering

- Traploos verstelbaar spanbereik tussen 1-13 mm
- n max = 20.000 min-1
- Geharde spanbekken

## Voordelen

- Hoge opspannauwkeurigheid en nauwkeurige balancerings bevorderen de levensduur en standtijd van de boorhouder
- Hoog spanmoment
- Geen binnendringen van spanen en vuil in het opspanbereik door speciale geharde spanbekken

## Informatie - Tip

- Voor rechts- en linksloop
- Inhoud van de verpakking: spansleutel, aantrekbout

## Producteigenschappen

## Bestelinformatie

| Ø D [mm]                 | Ø d [mm] | Ø d1 [mm] | L1 [mm]       |                                    | VE [St.] | V | Bestelnummer |
|--------------------------|----------|-----------|---------------|------------------------------------|----------|---|--------------|
| 50                       | HSK 63F  | 1-13      | 112           | Homag, EIMA, Weeke, IMA vanaf 9/94 | 1        |   | 180381       |
| 57                       | HSK 63F  | 3-16      | 112           | Homag, EIMA, Weeke, IMA vanaf 9/94 | 1        |   | 180382       |
| Toebehoren               |          |           | Afmeting [mm] |                                    | VE [St.] | V | Bestelnummer |
| Haakse schroevendraaiers |          |           | SW6x100       |                                    | 1        | o | 180383       |

## Spantangopname met SK-schacht

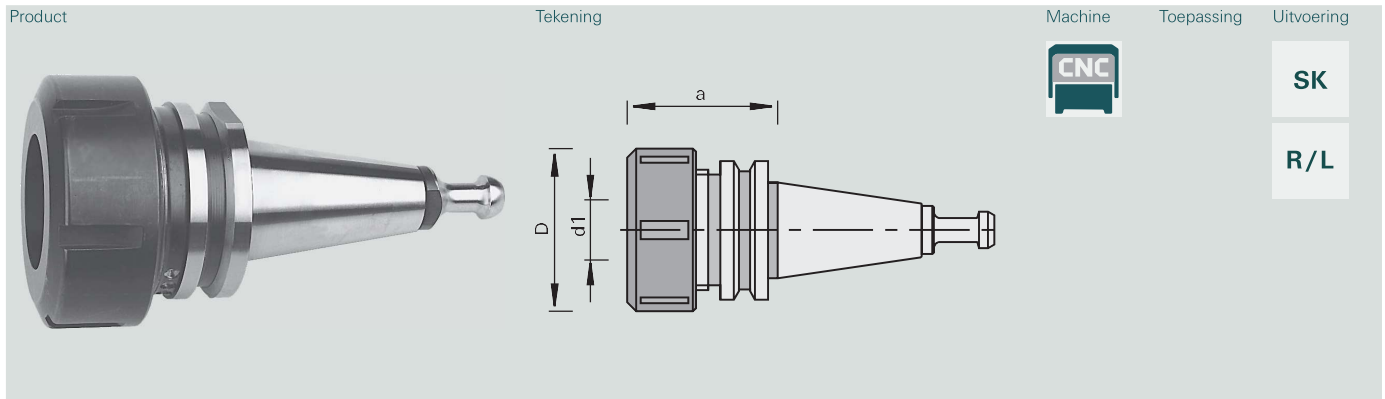

## Machine / gebruiksaanwijzing

- CNC-bewerkingscentra met automatische gereedschapwisselaar
- Voor het opspannen van schacht-gereedschap met cilindrische schacht

## Uitvoering

- Steile conus volgens DIN 69871 en ISO (zonder meenemers- en fixeergroeven)
- Spanmoer met glijlager

## Voordelen

- Minimaliseren van de gereedschapvoorbereidingstijd door snelle, eenvoudige gereedschapwisseling
- Lange standtijd en goede snijkwaliteit door hoge rondloopprecisie

## Informatie - Tip

- Voor rechts- en linksloop
- Spantangen volgens type 470E/ER32  $\varnothing$  2 - 20mm
- Spantangen volgens type 472E/ER40  $\varnothing$  4 - 25mm
- Inhoud van de verpakking: spantang-opname, spanmoer en aantrekbout (Biesse 173641)

## Producteigenschappen

| $\varnothing$ D [mm] | $\varnothing$ d [mm] | $\varnothing$ d1 [mm] | a [mm] | Type      |        |  |  |  | VE [St.] | V Bestelnummer |
|----------------------|----------------------|-----------------------|--------|-----------|--------|--|--|--|----------|----------------|
| 50                   | SK 30 (DIN ISO)      | 2-20                  | 50     | 470E/ER32 | Biesse |  |  |  | 1        | 173639         |
| 63                   | SK 30 (DIN ISO)      | 4-25                  | 57     | 472E/ER40 | Biesse |  |  |  | 1        | 175790         |

## Bestelinformatie

| Toebehoren               | Afmeting [mm]  |                                   |  | VE [St.] | V Bestelnummer |
|--------------------------|----------------|-----------------------------------|--|----------|----------------|
| Spanmoeren met glijlager | M50x1,5R       | Voor $\varnothing$ D = 63         |  | 1        | o 178762       |
| Aantrekbout              |                | HSD-motor voor Biesse vanaf 09/92 |  | 1        | 173641         |
| Aantrekbout              |                | Voor Biesse tot 08/92             |  | 1        | o 175637       |
| Haaksleutel              | 58/62 DIN 1810 | Voor $\varnothing$ D = 63         |  | 1        | 169299         |
|                          | 58/62 DIN 1810 | Voor $\varnothing$ D = 63         |  | 1        | 186765         |
| Spanmoeren met glijlager | M40x1,5R       | Voor $\varnothing$ D = 50         |  | 1        | 178761         |
|                          | 40-200 Nm      |                                   |  | 1        | 184890         |
| Haaksleutel              | 45/50 DIN 1810 | Voor $\varnothing$ D = 50         |  | 1        | 175851         |
|                          | 45/50 DIN 1810 | Voor $\varnothing$ D = 50         |  | 1        | 186467         |

## Spantangenopname met SK-schacht met tandkrans

Product

Tekening

Machine

Toepassing

Uitvoering

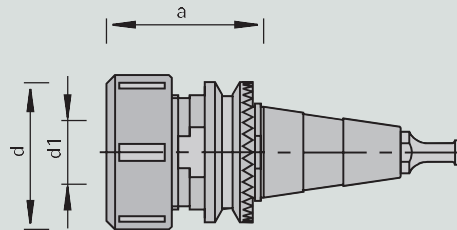

SK

R/L

Machine / gebruiksaanwijzing

- CNC-bewerkingscentra met automatische gereedschapwisselaar
- Voor het opspannen van schacht-gereedschap met cilindrische schacht

Uitvoering

- Steile conus volgens SK 30 met tandkrans
- Spanmoer met glijlager

Voordelen

- Minimaliseren van de gereedschap-voorbereidingstijd door snelle, eenvoudige gereedschapwisseling
- Lange standtijd en goede snijkwaliteit door hoge rondloopprecisie

Informatie - Tip



- Voor rechts- en linksloop
- Aantrekbout verwisselbaar
- Spantangen volgens type 462E/OZ25  $\varnothing$  4 - 25mm
- Spantangen volgens type 470E/ER32  $\varnothing$  2 - 20mm
- Inhoud van de verpakking: spantang-opname, spanmoer en aantrekbout

Producteigenschappen

Bestelinformatie

| $\varnothing$ D [mm]     | $\varnothing$ d [mm] | $\varnothing$ d1 [mm] | a [mm] | Type      |                           | VE [St.] | V Bestelnummer |
|--------------------------|----------------------|-----------------------|--------|-----------|---------------------------|----------|----------------|
| 50                       | SK 30                | 2-20                  | 55     | 470E/ER32 | SCM, Morbidelli           | 1        | 173644         |
| 60                       | SK 30                | 4-25                  | 72     | 462E/OZ25 | SCM, Morbidelli           | 1        | 175792         |
| Toebehoren               |                      | Afmeting [mm]         |        |           |                           | VE [St.] | V Bestelnummer |
| Spanmoeren met glijlager |                      | M40x1,5R              |        |           | Voor $\varnothing$ D = 50 | 1        | 178761         |
| Aantrekbout              |                      | Ø8,5                  |        |           |                           | 1        | 173646         |
| Haaksleutel              |                      | 45/50 DIN 1810        |        |           | Voor $\varnothing$ D = 50 | 1        | 175851         |
| Haaksleutel              |                      | 58/62 DIN 1810        |        |           | Voor $\varnothing$ D = 60 | 1        | 169299         |

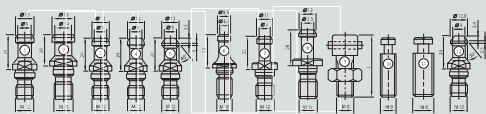
# Aantrekbout

|         |  |   |            |   |
|---------|--|---|------------|---|
| Product | Tekening   | Machine   | Toepassing | Uitvoering  |
|         |  |  |            | <div style="border: 1px solid black; padding: 2px; margin-bottom: 5px;">BT</div> <div style="border: 1px solid black; padding: 2px;">SK</div> |

|  |            |           |  |
|--|------------|-----------|--|
| Machine / gebruiksaanwijzing   | Uitvoering | Voordelen | Informatie - Tip   |
| <ul style="list-style-type: none"> <li>Voor de toepassing bij Hydrospankop PS 2000-E, adapter en spantangopname met SK + BT-schacht</li> </ul> |            |           | <ul style="list-style-type: none"> <li>Aanslagschroef voor gereedschappen met schachtdiameter 25 mm</li> </ul> |

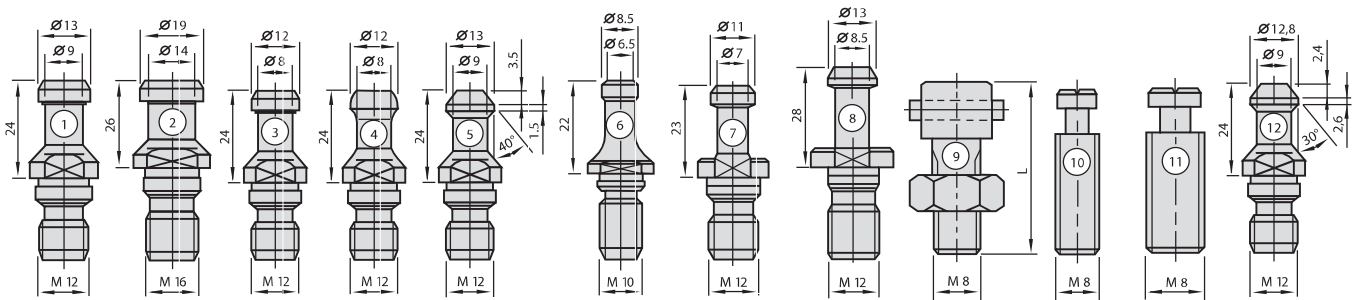

| Producteigenschappen                      |      | Bestelinformatie  |          |                |
|---|------|---|----------|----------------|
|   | Type |   | VE [St.] | V Bestelnummer |
| Voor SK 30                                | 1    | IMA, Maka, Reichenbacher, Weeke   | 1        | 169293         |
| Voor SK 40 met ontluchting                | 2    | IMA, Reichenbacher, Stegherr  | 1        | o 169294       |
| Voor SK 40                                | 2    | IMA, Reichenbacher, Stegherr, Maka                                      | 1        | 179339         |
| Voor SK 30                                | 3    | Rover oud, Biesse tot 08/92   | 1        | o 175637       |
| Voor SK 30                                | 4    | Rover nieuw, Biesse (HSD-motor) vanaf 09/92, Masterwood (Colombo-motor) | 1        | 173641         |
| Voor SK 30                                | 5    | Alberti   | 1        | o 177020       |
| Voor CMS                                  | 12   | CMS, Masterwood   | 1        | 177021         |
| Aantrekbout Ø 8,5 mm                      | 6    | Morbidelli, SCM   | 1        | 173646         |
| Voor BT 30                                | 7    | Shoda   | 1        | o 176200       |
| Voor BT 35                                | 8    | Heian   | 1        | 176103         |
| Voor ps-systeem 25 mm bestelnummer 173752 | 9    | ps-System   | 1        | 172113         |
| Voor PS-2000 E bestelnummer 173352        | 10   | PS 2000-E   | 1        | 172921         |
| Aanslagschroef                            | 11   | Spantangopspanning  | 10       | 172828         |

## Spantangopname met HSK-63F

Product

Tekening

Machine

Toepassing

Uitvoering

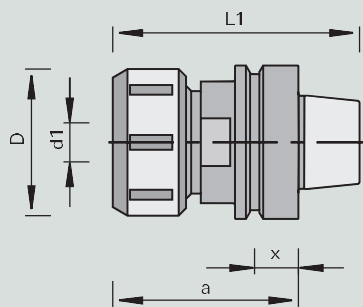

HSK



Machine / gebruiksaanwijzing

- CNC-bewerkingscentra met automatische gereedschapwisselaar
- Voor het nauwkeurig opspannen van schachtgereedschappen met cilindrische schacht

Uitvoering

- Gereedschaphouder volgens DIN 69893, HSK 63F
- Spanmoer met glijlager

Voordelen

- Flexibele toepassing via spantangen

Informatie - Tip



- Voor rechts- en linksloop
- $\emptyset d1$  = spantangdiameter 2 - 25 mm
- Spantangen volgens DIN 6388 type 462 E/OZ25
- Leveringsomvang: spantangopname, spanmoer zonder haaksleutel
- Let op: bij CMS-machines verschillende interfaces, afhankelijk van het TPM

Producteigenschappen

Bestelinformatie

| $\emptyset D$<br>[mm] | $\emptyset d1$<br>[mm] | $\emptyset d$<br>[mm] | L1<br>[mm]       | a<br>[mm] | x<br>[mm] |  | VE<br>[St.] | V | Bestelnummer |
|-----------------------|------------------------|-----------------------|------------------|-----------|-----------|--|-------------|---|--------------|
| 60                    | 2-25                   | HSK 63F               | 101              | 76        | 18        | Homag, IMA vanaf 01/95, Weeke vanaf 03/98, HOLZ-HER, SCM, CMS (12+15 kW) | 1           |   | 50811234     |
| 60                    | 2-25                   | HSK 63F               | 140              | 115       | 18        | Homag, IMA vanaf 01/95, Weeke vanaf 03/98, HOLZ-HER, CMS (12+15 kW)      | 1           |   | 179170       |
| Toebehoren            |                        |                       | Afmeting<br>[mm] |           |           |  | VE<br>[St.] | V | Bestelnummer |
| Haaksleutel           |                        |                       | 58/62 DIN 1810   |           |           |  | 1           |   | 169299       |
| Momentsleutel         |                        |                       | 40-200 Nm        |           |           |  | 1           |   | 184890       |

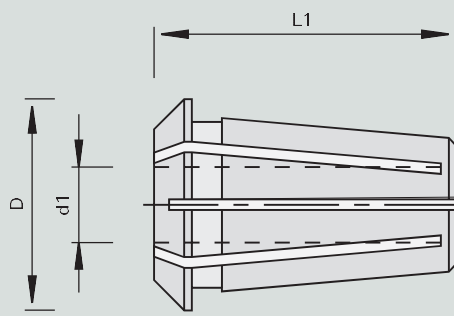
## Precisiespantangen - 462E/OZ25

|  |  |  |
|--|--|--|
| <p>Product</p>  | <p>Tekening</p>  | <p>Machine</p>  <p>Toepassing</p> <p>Uitvoering</p> |
|--|--|--|

|   |  |  |                         |
|---|--|--|-------------------------|
| <p>Machine / gebruiksaanwijzing</p> <ul style="list-style-type: none"> <li>• Voor toepassing bij spantangopname type 462E/OZ25</li> </ul> | <p>Uitvoering</p> <ul style="list-style-type: none"> <li>• Opspantolerantie 0,5 mm</li> <li>• Volgens DIN 6388 Type 462E/OZ25</li> </ul> | <p>Voordelen</p> <ul style="list-style-type: none"> <li>• Optimale spankrachtoverbrenging door dubbelzijdige 12-voudige sleuven</li> </ul> | <p>Informatie - Tip</p> |
|---|--|--|-------------------------|

| Producteigenschappen |             |         | Bestelinformatie |   |              |
|----------------------|-------------|---------|------------------|---|--------------|
| Ø d1 [mm]            | Ø d1 [inch] | L1 [mm] | VE [St.]         | V | Bestelnummer |
| 2                    |             | 52      | 1                |   | 183803       |
| 3                    |             | 52      | 1                |   | 183804       |
| 4                    |             | 52      | 1                |   | 183805       |
| 5                    |             | 52      | 1                |   | 183806       |
| 6                    |             | 52      | 1                |   | 180213       |
|                      | 1/4"        | 52      | 1                |   | 175815       |
| 7                    |             | 52      | 1                | o | 183807       |
| 8                    |             | 52      | 1                |   | 180358       |
| 9,5                  |             | 52      | 1                |   | 175817       |
|                      | 3/8"        | 52      | 1                |   | 185275       |
| 10                   |             | 52      | 1                |   | 170782       |
| 12                   |             | 52      | 1                |   | 168742       |
|                      | 1/2"        | 52      | 1                |   | 175820       |
| 13                   |             | 52      | 1                |   | 180215       |
| 14                   |             | 52      | 1                |   | 170783       |
|                      | 5/8"        | 52      | 1                |   | 175823       |
| 15                   |             | 52      | 1                | o | 183808       |
| 16                   |             | 52      | 1                |   | 168743       |
| 18                   |             | 52      | 1                |   | 180216       |
|                      | 3/4"        | 52      | 1                |   | 175826       |
| 20                   |             | 52      | 1                |   | 168744       |
| 25                   |             | 52      | 1                |   | 168745       |



## Precisiespantangen - 415E/OZ16

Product

Tekening

Machine

Toepassing

Uitvoering

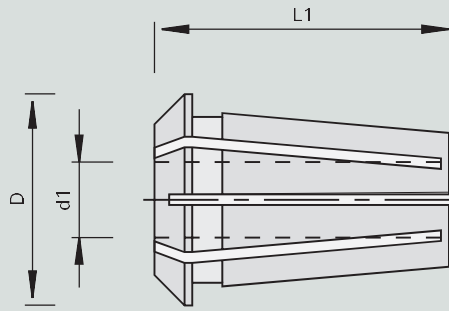

Machine / gebruiksaanwijzing

Uitvoering

Voordelen

Informatie - Tip

- Voor toepassing bij spantangopname type 415E/OZ16
- Dubbelzijdige spangleuven
- Opspantolerantie 0,5 mm
- Volgens DIN 6388 type 415E/OZ16

Producteigenschappen

Bestelinformatie

| Ø d1<br>[mm] | Ø D<br>[mm] | L1<br>[mm] |  |  |  |  |  |  |  | VE<br>[St.] | V | Bestelnummer |
|--------------|-------------|------------|--|--|--|--|--|--|--|-------------|---|--------------|
| 2,5          | 25,5        | 40         |  |  |  |  |  |  |  | 1           | o | 820753       |
| 3            | 25,5        | 40         |  |  |  |  |  |  |  | 1           | o | 820754       |
| 4            | 25,5        | 40         |  |  |  |  |  |  |  | 1           | o | 820494       |
| 4,5          | 25,5        | 40         |  |  |  |  |  |  |  | 1           | o | 830236       |
| 5            | 25,5        | 40         |  |  |  |  |  |  |  | 1           | o | 820495       |
| 6            | 25,5        | 40         |  |  |  |  |  |  |  | 1           | o | 170779       |
| 6,35         | 25,5        | 40         |  |  |  |  |  |  |  | 1           | o | 821421       |
| 7            | 25,5        | 40         |  |  |  |  |  |  |  | 1           | o | 829692       |
| 8            | 25,5        | 40         |  |  |  |  |  |  |  | 1           |   | 170780       |
| 9            | 25,5        | 40         |  |  |  |  |  |  |  | 1           | o | 825190       |
| 9,5          | 25,5        | 40         |  |  |  |  |  |  |  | 1           | o | 168739       |
| 10           | 25,5        | 40         |  |  |  |  |  |  |  | 1           |   | 170781       |
| 12           | 25,5        | 40         |  |  |  |  |  |  |  | 1           |   | 168740       |
| 12,7         | 25,5        | 40         |  |  |  |  |  |  |  | 1           | o | 830156       |
| 13           | 25,5        | 40         |  |  |  |  |  |  |  | 1           | o | 821221       |
| 16           | 25,5        | 40         |  |  |  |  |  |  |  | 1           |   | 168741       |

## Precisiespantangen - 430E/ER25, 470E/ER32, 472E/ER40

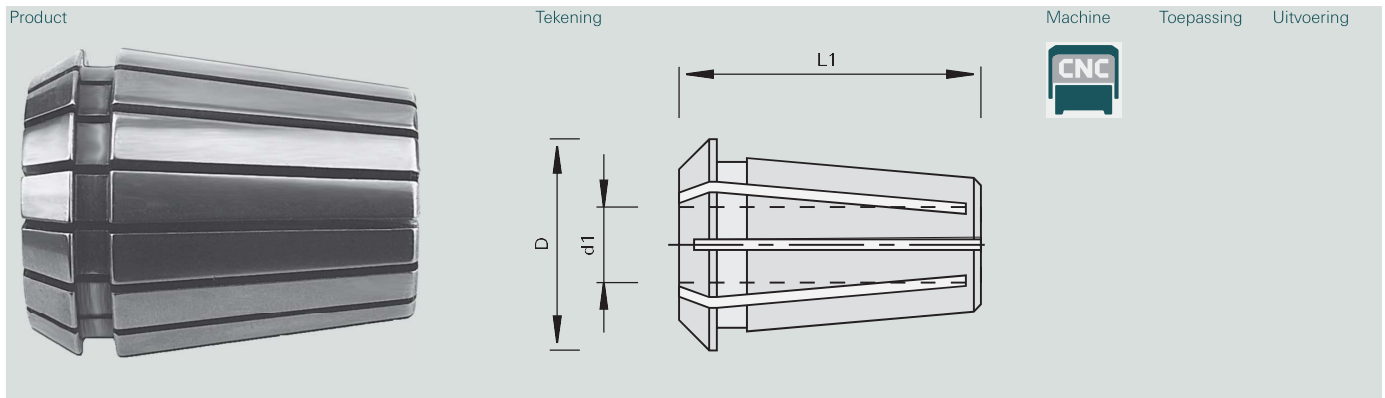

|   |  |           |   |
|---|--|-----------|---|
| Machine / gebruiksaanwijzing  | Uitvoering   | Voordelen | Informatie - Tip  |
| <ul style="list-style-type: none"> <li>Voor toepassing bij spantangopname type 430E/ER25, 470E/ER32, 472E/ER40</li> </ul> | <ul style="list-style-type: none"> <li>Dubbelzijdige spangleuven</li> <li>Opspantolerantie 1 mm</li> </ul> |           | <ul style="list-style-type: none"> <li>Type 430E/ER25 Ø 6-16 mm voor speciaal-opspanningen</li> <li>Type 470E/ER32 Ø 3-20 mm</li> <li>Type 472E/ER40 Ø 6-25 mm</li> </ul> |

| Producteigenschappen |             |          |         |           | Bestelinformatie |   |              |
|----------------------|-------------|----------|---------|-----------|------------------|---|--------------|
| Ø d1 [mm]            | Ø d1 [inch] | Ø D [mm] | L1 [mm] | Type      | VE [St.]         | V | Bestelnummer |
| 3                    |             | 33       | 40      | 470E/ER32 | 1                | o | 173647       |
| 4                    |             | 33       | 40      | 470E/ER32 | 1                | o | 173648       |
| 5                    |             | 33       | 40      | 470E/ER32 | 1                | o | 173649       |
| 6                    |             | 33       | 40      | 470E/ER32 | 1                |   | 173650       |
| 7                    |             | 33       | 40      | 470E/ER32 | 1                | o | 173651       |
| 8                    |             | 33       | 40      | 470E/ER32 | 1                |   | 173652       |
| 10                   |             | 33       | 40      | 470E/ER32 | 1                |   | 173653       |
| 12                   |             | 33       | 40      | 470E/ER32 | 1                |   | 173654       |
| 13                   |             | 33       | 40      | 470E/ER32 | 1                | o | 173655       |
| 14                   |             | 33       | 40      | 470E/ER32 | 1                | o | 173656       |
| 16                   |             | 33       | 40      | 470E/ER32 | 1                |   | 173657       |
| 18                   |             | 33       | 40      | 470E/ER32 | 1                | o | 173658       |
| 19                   |             | 33       | 40      | 470E/ER32 | 1                | o | 173659       |
| 20                   |             | 33       | 40      | 470E/ER32 | 1                |   | 173660       |
|                      | 1/4"        | 33       | 40      | 470E/ER32 | 1                |   | 175829       |
|                      | 1/2"        | 33       | 40      | 470E/ER32 | 1                |   | 175830       |
|                      | 5/8"        | 33       | 40      | 470E/ER32 | 1                | o | 175831       |
|                      | 3/4"        | 33       | 40      | 470E/ER32 | 1                | o | 175832       |
| 6                    |             | 41       | 46      | 472E/ER40 | 1                | o | 180912       |
| 8                    |             | 41       | 46      | 472E/ER40 | 1                |   | 180913       |
| 10                   |             | 41       | 46      | 472E/ER40 | 1                | o | 180914       |
| 12                   |             | 41       | 46      | 472E/ER40 | 1                |   | 175833       |
| 16                   |             | 41       | 46      | 472E/ER40 | 1                |   | 175834       |
| 18                   |             | 41       | 46      | 472E/ER40 | 1                | o | 175835       |
| 20                   |             | 41       | 46      | 472E/ER40 | 1                |   | 175836       |
| 25                   |             | 41       | 46      | 472E/ER40 | 1                |   | 175837       |
|                      | 1/4"        | 41       | 46      | 472E/ER40 | 1                | o | 175838       |
|                      | 1/2"        | 41       | 46      | 472E/ER40 | 1                | o | 175839       |
|                      | 5/8"        | 41       | 46      | 472E/ER40 | 1                | o | 175840       |
|                      | 3/4"        | 41       | 46      | 472E/ER40 | 1                | o | 175841       |
|                      | 1"          | 41       | 46      | 472E/ER40 | 1                | o | 175842       |
| 6                    |             | 26       | 34      | 430E/ER25 | 1                | o | 181986       |
| 8                    |             | 26       | 34      | 430E/ER25 | 1                |   | 181987       |
| 10                   |             | 26       | 34      | 430E/ER25 | 1                |   | 181988       |
| 12                   |             | 26       | 34      | 430E/ER25 | 1                |   | 181989       |
| 14                   |             | 26       | 34      | 430E/ER25 | 1                | o | 181990       |
| 16                   |             | 26       | 34      | 430E/ER25 | 1                |   | 181991       |

## Hydro-opname ps-System met HSK63F

Product



Tekening

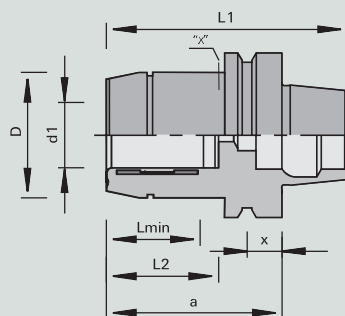

Machine



Toepassing

Uitvoering

HSK

 max.  
**30.000**  
 U/min

R/L

Machine / gebruiksaanwijzing

- CNC-bewerkingscentra met automatische gereedschapwisselaar
- Voor het nauwkeurig opspannen van schachtgereedschappen met cilindrische schacht

Uitvoering

- n max = 30.000 min -1
- Gereedschaphouder DIN 69893 HSK 63 F

Voordelen

- Minimaliseren van de gereedschapvoorbereidingstijd door snelle, eenvoudige gereedschapwisseling
- Lange standtijd en goede snijkwaliteit door hoge rondloopprecisie
- Hoge koppeloverbrenging

Informatie - Tip

- Voor rechts- en linksloop
- Met boring voor het aanbrengen van microchips voor de elektronische gereedschaperkenning
- x = druktoevoer via schroevendraaier
- Inbusschroevendraaier is niet inbegrepen
- Lmin minimale opspanlengte = minimale schachtlengte

Producteigenschappen

| Ø d1 [mm] | Lmin [mm] | L2 [mm] | Ø d [mm] | Ø D [mm] | L1 [mm] | a [mm] | x [mm] | Gewicht [kg] | VE [St.] | V | Bestelnummer |
|-----------|-----------|---------|----------|----------|---------|--------|--------|--------------|----------|---|--------------|
| 10        | 31        | 41      | HSK 63F  | 30       | 105     | 80     | 18     | 1.2          | 1        |   | 184725       |
| 12        | 36        | 46      | HSK 63F  | 32       | 105     | 80     | 18     | 1.16         | 1        |   | 184306       |
| 16        | 39        | 49      | HSK 63F  | 38       | 105     | 80     | 18     | 1.20         | 1        |   | 184307       |
| 20        | 41        | 51      | HSK 63F  | 52.5     | 105     | 80     | 18     | 1.30         | 1        |   | 184308       |
| 25        | 47        | 57      | HSK 63F  | 52.5     | 109     | 84     | 18     | 1.28         | 1        |   | 184309       |

Bestelinformatie

Producteigenschappen

| Ø d1 [inch] | Lmin [mm] | L2 [mm] | Ø d [mm] | Ø D [mm] | L1 [mm] | a [mm] | x [mm] | Gewicht [kg] | VE [St.] | V | Bestelnummer |
|-------------|-----------|---------|----------|----------|---------|--------|--------|--------------|----------|---|--------------|
| 3/8"        | 31        | 41      | HSK 63F  | 30       | 105     | 80     | 18     | 1.2          | 1        |   | 184724       |
| 1/2"        | 36        | 47,5    | HSK 63F  | 32       | 105     | 80     | 18     | 1.2          | 1        |   | 184726       |

Bestelinformatie

| Toebehoren       | Afmeting [mm] | Passend voor                   | VE [St.] | V | Bestelnummer |
|------------------|---------------|--------------------------------|----------|---|--------------|
| Schroevendraaier | SW4x100       | 184306, 184724, 184725, 184726 | 1        |   | 166091       |
| Schroevendraaier | SW5x150       | 184307, 184308, 184309         | 1        |   | 168703       |

## Universele reduceerhulzen

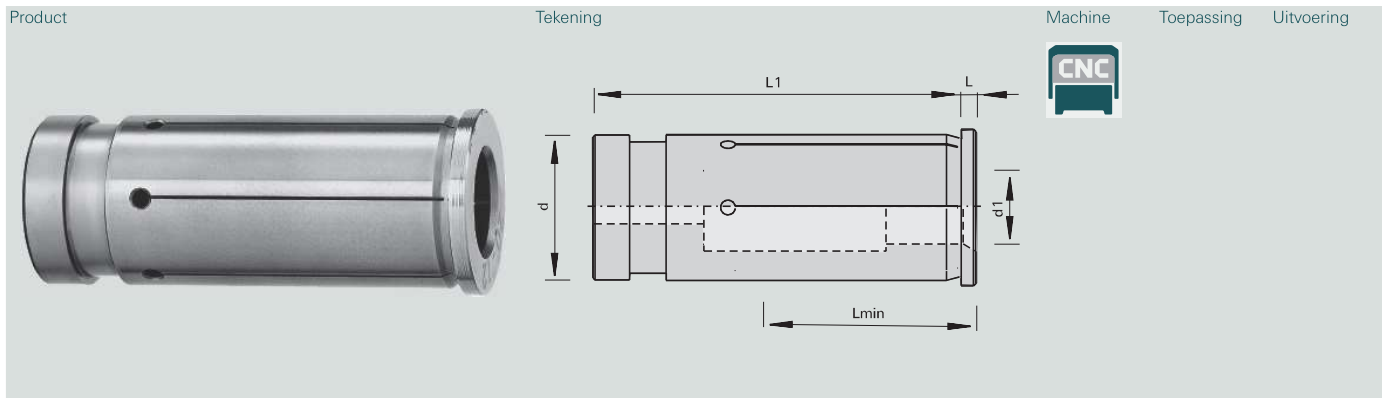

## Machine / gebruiksaanwijzing

- Voor de toepassing bij het Sino, TRIBOS, PS-systeem voor het opspannen van schachtgereedschap

## Uitvoering

- Schachtdiameter-tolerantie H7 c.q. g7

## Voordelen

## Informatie - Tip



- Lmin minimale opspanlengte = minimale schachtlengte

## Producteigenschappen

## Bestelinformatie

| Ø d1 [mm] | Ø d1 [inch] | Lmin [mm] | Ø d [mm] | L1 [mm] |  |  |  | VE [St.] | V | Bestelnummer |
|-----------|-------------|-----------|----------|---------|--|--|--|----------|---|--------------|
| 3         |             | 27        | 12       | 45      |  |  |  | 1        | o | 183022       |
| 4         |             | 27        | 12       | 45      |  |  |  | 1        | o | 183023       |
| 5         |             | 27        | 12       | 45      |  |  |  | 1        | o | 183024       |
| 6         |             | 27        | 12       | 45      |  |  |  | 1        |   | 183025       |
| 8         |             | 27        | 12       | 45      |  |  |  | 1        |   | 183026       |
| 3         |             | 27        | 20       | 50.5    |  |  |  | 1        | o | 183027       |
| 4         |             | 27        | 20       | 50.5    |  |  |  | 1        | o | 183028       |
| 5         |             | 27        | 20       | 50.5    |  |  |  | 1        | o | 183029       |
| 6         |             | 27        | 20       | 50.5    |  |  |  | 1        | o | 183030       |
| 8         |             | 27        | 20       | 50.5    |  |  |  | 1        |   | 183032       |
| 10        |             | 32        | 20       | 50.5    |  |  |  | 1        |   | 183034       |
| 12        |             | 37        | 20       | 50.5    |  |  |  | 1        |   | 183036       |
| 14        |             | 37        | 20       | 50.5    |  |  |  | 1        | o | 183038       |
| 16        |             | 38        | 20       | 50.5    |  |  |  | 1        |   | 183040       |
| 6         |             | 27        | 25       | 54.5    |  |  |  | 1        |   | 182304       |
| 8         |             | 27        | 25       | 54.5    |  |  |  | 1        |   | 182305       |
| 10        |             | 32        | 25       | 54.5    |  |  |  | 1        |   | 182306       |
| 12        |             | 37        | 25       | 54.5    |  |  |  | 1        |   | 182307       |
| 14        |             | 37        | 25       | 54.5    |  |  |  | 1        |   | 182308       |
| 16        |             | 38        | 25       | 54.5    |  |  |  | 1        |   | 182309       |
| 18        |             | 38        | 25       | 54.5    |  |  |  | 1        |   | 182310       |
| 20        |             | 42        | 25       | 54.5    |  |  |  | 1        |   | 182311       |
|           | 1/2"        | 37        | 25       | 54.5    |  |  |  | 1        |   | 182653       |
|           | 3/4"        | 42        | 25       | 54.5    |  |  |  | 1        |   | 182655       |
| 10        |             | 32        | 16       | 47.5    |  |  |  | 1        |   | 186100       |
| 12        |             | 37        | 16       | 47.5    |  |  |  | 1        |   | 186101       |
| 8         |             | 27        | 16       | 47.5    |  |  |  | 1        |   | 186099       |

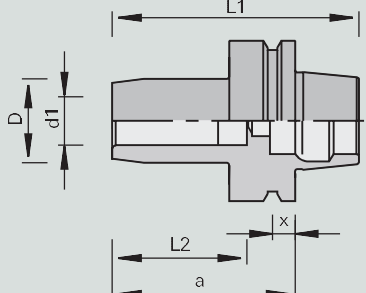
## TRIBOS high-tech spantanghouder

|  |  |  |                   |   |
|--|--|--|-------------------|---|
| <p>Product</p>  | <p>Tekening</p>  | <p>Machine</p>  | <p>Toepassing</p> | <p>Uitvoering</p> <div style="border: 1px solid black; padding: 5px;"> <p><b>HSK</b></p> <p>max. <b>40.000</b> U/min</p>  <p><b>R/L</b></p> </div> |
|--|--|--|-------------------|---|



|  |  |  |  |
|--|--|--|--|
| <p>Machine / gebruiksaanwijzing</p> <ul style="list-style-type: none"> <li>• CNC-bewerkingscentra met automatische gereedschapwisselaar</li> <li>• Voor het nauwkeurig opspannen van schachtgereedschappen met cilindrische schacht</li> </ul> | <p>Uitvoering</p> <ul style="list-style-type: none"> <li>• n max = 40.000 min-1</li> </ul> | <p>Voordelen</p> <ul style="list-style-type: none"> <li>• Ontzien van de machinelagers door gering gewicht</li> <li>• Geschikt voor hoge toerentallen</li> <li>• Optimale spaanafzuiging door slanke constructie</li> <li>• Hoge betrouwbaarheid van de bewerking, hoge standtijd en hoge bewerkings kwaliteit vanwege de hoge precisie en tolerantie: (&lt; 0,003)</li> </ul> | <p>Informatie - Tip</p> <ul style="list-style-type: none"> <li>• Voor rechts- en linksloop</li> <li>• Afwijkende diameter op aanvraag</li> <li>• Opspannen van de gereedschappen met behulp van en volgens richtlijnen van spaninrichting</li> <li>• Kan desgewenst ook door Stehle worden uitgevoerd</li> <li>• TRIBOS-opspanning in versterkte uitvoering, speciaal voor zware verspaning, zijn op aanvraag leverbaar</li> <li>• Inhoud van de verpakking: zonder aantrekbout; keuze van de aantrekbout passend bij de machine (zie afzonderlijke pagina Aantrekbouten)</li> </ul> |
|--|--|--|--|

| Producteigenschappen |         |          |          |         |        |        |              | Bestelinformatie |   |              |
|----------------------|---------|----------|----------|---------|--------|--------|--------------|------------------|---|--------------|
| Ø d1 [mm]            | L2 [mm] | Ø d [mm] | Ø D [mm] | L1 [mm] | a [mm] | x [mm] | Gewicht [kg] | VE [St.]         | V | Bestelnummer |
| 12                   | 48,5    | HSK 63F  | 19       | 100     | 75     | 18     | 0.69         | 1                |   | 180257       |
| 16                   | 48,5    | HSK 63F  | 26       | 100     | 75     | 18     | 0.74         | 1                |   | 180899       |
| 20                   | 52,9    | HSK 63F  | 30       | 100     | 75     | 18     | 0.77         | 1                |   | 180258       |
| 25                   | 55      | HSK 63F  | 35       | 100     | 75     | 18     | 0.79         | 1                |   | 180710       |

| Producteigenschappen |         |             |          |         |        |  |  | Bestelinformatie |   |              |
|----------------------|---------|-------------|----------|---------|--------|--|--|------------------|---|--------------|
| Ø d1 [mm]            | L2 [mm] | Ø d [mm]    | Ø D [mm] | L1 [mm] | a [mm] |  |  | VE [St.]         | V | Bestelnummer |
| 20                   | 55      | SK 30 (DIN) | 30       | 127     | 80     |  |  | 1                |   | 180888       |
| 25                   | 55      | SK 30 (DIN) | 35       | 127     | 80     |  |  | 1                |   | 180836       |

| Toebehoren                            |  |  |  |                        |  |  |  | VE [St.] | V | Bestelnummer |
|---------------------------------------|--|--|--|------------------------|--|--|--|----------|---|--------------|
| Reduceerinzet voor montagevoorziening |  |  |  | Voor Ø d = 6           |  |  |  | 1        | o | 183719       |
| Reduceerinzet voor montagevoorziening |  |  |  | Voor Ø d = 8           |  |  |  | 1        | o | 183720       |
| Reduceerinzet voor montagevoorziening |  |  |  | Voor Ø d = 10          |  |  |  | 1        | o | 183721       |
| Reduceerinzet voor montagevoorziening |  |  |  | Voor Ø d = 12          |  |  |  | 1        |   | 180263       |
| Reduceerinzet voor montagevoorziening |  |  |  | Voor Ø d = 20          |  |  |  | 1        |   | 180264       |
| Reduceerinzet voor montagevoorziening |  |  |  | Voor Ø d = 16          |  |  |  | 1        |   | 180902       |
| Reduceerinzet voor montagevoorziening |  |  |  | Voor Ø d = 25          |  |  |  | 1        |   | 180711       |
| Interfacekabel voor instelmallen      |  |  |  | Voor RS 232C-interface |  |  |  | 1        | o | 180829       |
| Lengte-instelapparaat TRIBOS-systeem  |  |  |  | Zonder interfacekabel  |  |  |  | 1        | o | 180828       |
| Montagevoorziening (automatisch)      |  |  |  |                        |  |  |  | 1        | o | 181159       |
| Montagevoorziening (handmatig)        |  |  |  |                        |  |  |  | 1        |   | 180261       |

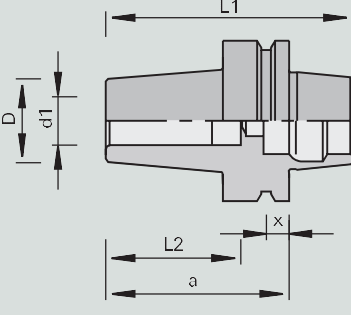
## High-tech krimpoppname

|  |   |  |                   |   |
|--|---|--|-------------------|---|
| <p>Product</p>  | <p>Tekening</p>  | <p>Machine</p>  | <p>Toepassing</p> | <p>Uitvoering</p> <p><b>HSK</b></p> <p>max.<br/><b>30.000</b><br/>U/min</p>  <p><b>R/L</b></p> |
|--|---|--|-------------------|---|

|  |   |  |  |
|--|---|--|--|
| <p>Machine / gebruiksaanwijzing</p> <ul style="list-style-type: none"> <li>• CNC-bewerkingscentra met automatische gereedschapwisselaar</li> <li>• Voor het nauwkeurig opspannen van schachtgereedschappen met cilindrische schacht</li> </ul> | <p>Uitvoering</p> <ul style="list-style-type: none"> <li>• n max = 30.000 min-1</li> <li>• Gereedschaphouder DIN 69893 HSK 63 F</li> <li>• Van hoogwaardig hittevast staal</li> </ul> | <p>Voordelen</p> <ul style="list-style-type: none"> <li>• Hoge betrouwbaarheid van de bewerking, hoge standtijd en hoge bewerkings kwaliteit vanwege de hoge precisie en enge tolerantie: (&lt; 0,003 mm)</li> </ul> | <p>Informatie - Tip</p> <ul style="list-style-type: none"> <li>• Voor rechts- en linksloop</li> <li>• Kan met alle in de handel gebruikelijke krimphouders gelost en opgespannen worden</li> </ul> |
|--|---|--|--|

| Producteigenschappen |         |          |          |         |        |        |              | Bestelinformatie |   |              |
|----------------------|---------|----------|----------|---------|--------|--------|--------------|------------------|---|--------------|
| Ø d1 [mm]            | L2 [mm] | Ø d [mm] | Ø D [mm] | L1 [mm] | a [mm] | x [mm] | Gewicht [kg] | VE [St.]         | V | Bestelnummer |
| 6,0                  | 36      | HSK 63F  | 20       | 100     | 75     | 18     | 0.797        | 1                |   | 186684       |
| 8,0                  | 36      | HSK 63F  | 20       | 100     | 75     | 18     | 0.790        | 1                |   | 186685       |
| 10                   | 41      | HSK 63F  | 26       | 100     | 75     | 18     | 0.840        | 1                |   | 183081       |
| 12                   | 47      | HSK 63F  | 28       | 100     | 75     | 18     | 0.830        | 1                |   | 183082       |
| 14                   | 47      | HSK 63F  | 28       | 100     | 75     | 18     | 0.870        | 1                |   | 183083       |
| 16                   | 51      | HSK 63F  | 28       | 100     | 75     | 18     | 0.850        | 1                |   | 183084       |
| 18                   | 51      | HSK 63F  | 30       | 100     | 75     | 18     | 0.960        | 1                |   | 183085       |
| 20                   | 51      | HSK 63F  | 30       | 100     | 75     | 18     | 0.930        | 1                |   | 183086       |
| 25                   | 51      | HSK 63F  | 30       | 100     | 75     | 18     | 0.860        | 1                |   | 183087       |
| 25                   | 134     | HSK 63F  | 36       | 185     | 160    | 18     | 1.943        | 1                |   | 185520       |

## Opspandoorn met HSK-63F

Product

Tekening

Machine

Toepassing

Uitvoering

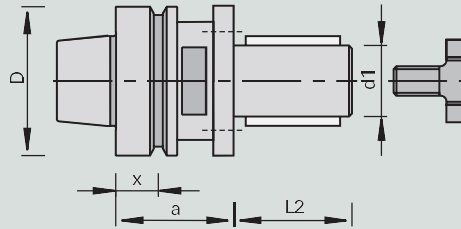

HSK



R/L

Machine / gebruiksaanwijzing

- CNC-bewerkingscentra met automatische gereedschapwisselaar
- Voor de nauwkeurige opspanning van boorgereedschap met dubbele spiebaan

Uitvoering

- Met 6 NL M6 - 8 mm diep TK Ø 48 mm
- Gereedschaphouder DIN 69893 HSK 63 F
- Spanlengte L2 = 50 mm voor meerdelige freesgereedschappen en messenkoppen
- Verdraaiblokkering door dubbele spie

Voordelen

- Grote aanvoer mogelijk door hoge koppeloverbrenging

Informatie - Tip

- Voor rechts- en linksloop
- Afstandsringset bestelnummer 181193 bestaat uit: 1 stuks 20 mm breed, 1 stuks 10 mm breed, 3 stuks 5 mm breed, 2 stuks 2 mm breed, 1 stuks 1 mm breed
- Afstandsringset bestelnummer 181194 extra 1 stuks 20 mm breed, 1 stuks 10 mm breed
- Gereedschapbevestiging via aantrekschroef
- Inhoud van de verpakking: spandoorn met aantrekschroef

Producteigenschappen

Bestelinformatie

| Ø D [mm] | Ø d [mm] | Ø d1 [mm] | L2 [mm] | a [mm] | x [mm] | DKN [mm] |                                  | VE [St.] | V Bestelnummer |
|----------|----------|-----------|---------|--------|--------|----------|----------------------------------|----------|----------------|
| 63       | HSK 63F  | 30        | 50      | 45     | 18     | 8 x 3    | Homag, IMA vanaf 01/95           | 1        | 183748         |
| 63       | HSK 63F  | 30        | 80      | 45     | 18     | 8 x 3    | Homag, IMA vanaf 01/95, HOLZ-HER | 1        | 183749         |
| 63       | HSK 63F  | 30        | 110     | 45     | 18     | 8 x 3    | Homag, IMA vanaf 01/95, HOLZ-HER | 1        | 183747         |

Toebehoren

Afmeting [mm]

VE [St.]

V Bestelnummer

|                                  |                 |   |        |
|----------------------------------|-----------------|---|--------|
| Tussenring-sets                  | 60x50x30        | 1 | 181193 |
| Tussenring-sets                  | 60x80x30        | 1 | 181194 |
| Aantrekschroef met centreerkraag | M16x38xØ48      | 1 | 184061 |
| Steeksleutel                     | SW46x10 DIN 894 | 1 | 178760 |

## Conusreiniger

Product Tekening Machine  Toepassing Uitvoering HSK





Machine / gebruiksaanwijzing Uitvoering Voordelen Informatie - Tip

- Voor het reinigen van conusopnamen
- Zeer nauwkeurige machine-as en spankop vereisen een stof- en spaanvrije passing

| Producteigenschappen |  |  |  | Bestelinformatie |                |
|----------------------|--|--|--|------------------|----------------|
| Ø d [mm]             |  |  |  | VE [St.]         | V Bestelnummer |
| HSK 63               |  |  |  | 1                | 180911         |

## Montage voorziening

Product Tekening Machine  Toepassing Uitvoering HSK



Machine / gebruiksaanwijzing Uitvoering Voordelen Informatie - Tip

- Voor het snel en eenvoudig monteren en instellen van gereedschap in spantangopnamen, freesdoorns en gereedschaphouders
- Gemonteerd op stabiele sokkel, die op de werkbank bevestigd kan worden
- Zeer eenvoudige bediening met uitstekend bedieningscomfort door rolspansysteem, geen opspannen of klemmen nodig
- Passend voor alle opspanningen HSK 63 F

| Producteigenschappen |  |  |  | Bestelinformatie |                |
|----------------------|--|--|--|------------------|----------------|
| Ø d1 [mm]            |  |  |  | VE [St.]         | V Bestelnummer |
| HSK 63F              |  |  |  | 1                | 182467         |



# VERWISSELBARE PLATEN/MESSEN

## Inhoud

Voorsnijders/ Omkeermessen

6-1

Mini-omkeermessen



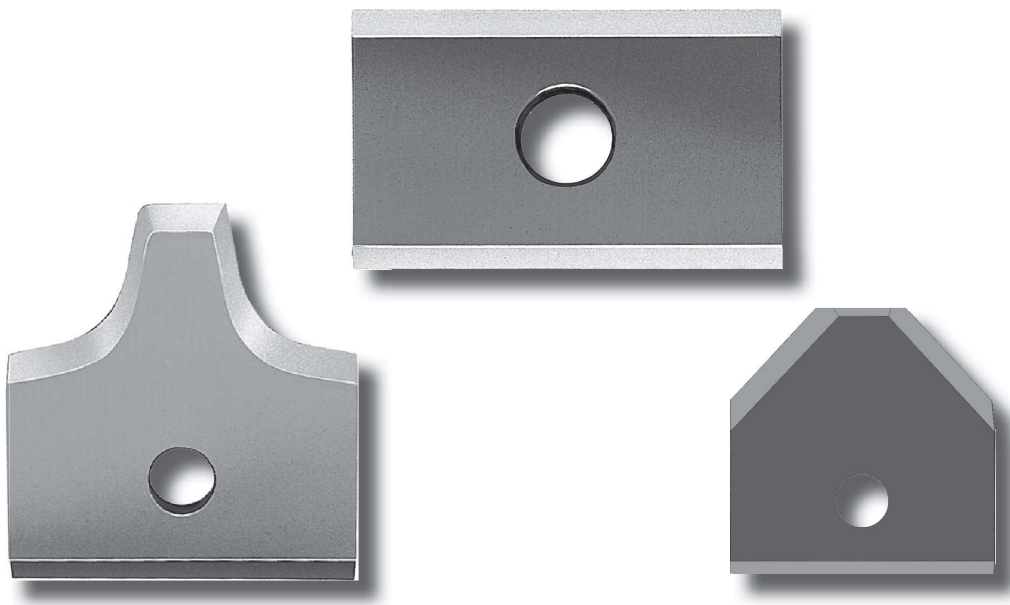

6-10

Handschaaf- omkeermessen

6-10

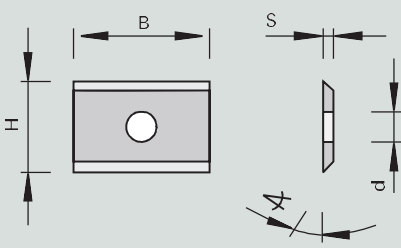





## HW Omkeermessen

|   |  |         |   |  |
|---|--|---------|---|--|
| Product   | Tekening   | Machine | Toepassing  | Uitvoering   |
|  |  |         |  | <br><br><b>HW TC05</b> |

|                              |  |   |   |
|------------------------------|--|---|---|
| Machine / gebruiksaanwijzing | Uitvoering   | Voordelen   | Informatie - Tip  |
|                              | <ul style="list-style-type: none"> <li>• Snijmateriaal HW</li> <li>• TC05 voor plaatmateriaal op basis van hout, kunststoffen en hardhout</li> </ul> | <ul style="list-style-type: none"> <li>• Lange standtijd bij uitstekende snijkwaliteit in massief hout</li> </ul> | <ul style="list-style-type: none"> <li>• Verpakkingseenheid 10 stuks</li> </ul> |

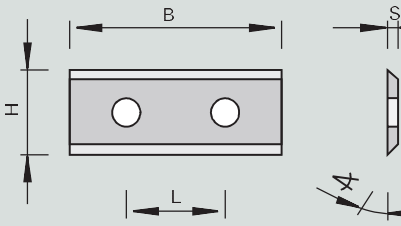
| Producteigenschappen |        |        |          |             |               |  | Bestelinformatie |   |              |
|----------------------|--------|--------|----------|-------------|---------------|--|------------------|---|--------------|
| B [mm]               | H [mm] | S [mm] | Ø d [mm] | Wighoek [°] | Snijmateriaal |  | VE [St.]         | V | Bestelnummer |
| 7,5                  | 12     | 1,5    | 4,0      | 55          | TC05          |  | 10               |   | 50820007     |
| 9,6                  | 12     | 1,5    | 4,0      | 55          | TC05          |  | 10               |   | 50820010     |
| 10,5                 | 12     | 1,5    | 4,0      | 55          | TC05          |  | 10               |   | 50450023     |
| 11                   | 12     | 1,5    | 4,0      | 55          | TC05          |  | 10               |   | 50450024     |
| 11,6                 | 12     | 1,5    | 4,0      | 55          | TC05          |  | 10               | s | 50820011     |
| 13                   | 12     | 1,5    | 4,0      | 55          | TC05          |  | 10               |   | 50450027     |
| 15                   | 12     | 1,5    | 4,0      | 55          | TC05          |  | 10               |   | 50820015     |
| 15,7                 | 12     | 1,5    | 4,0      | 55          | TC05          |  | 10               |   | 50450030     |
| 17                   | 12     | 1,5    | 4,0      | 55          | TC05          |  | 10               |   | 50450031     |
| 18                   | 12     | 1,5    | 4,0      | 55          | TC05          |  | 10               | # | 50450032     |
| 20                   | 12     | 1,5    | 4,0      | 55          | TC05          |  | 10               |   | 50820020     |

## HW Omkeermessen

|   |  |         |   |  |
|---|--|---------|---|--|
| Product   | Tekening   | Machine | Toepassing  | Uitvoering   |
|  |  |         |  | <br><br><b>HW TC05</b> |

|                              |  |   |   |
|------------------------------|--|---|---|
| Machine / gebruiksaanwijzing | Uitvoering   | Voordelen   | Informatie - Tip  |
|                              | <ul style="list-style-type: none"> <li>• Snijmateriaal HW</li> <li>• TC05 voor plaatmateriaal op basis van hout, kunststoffen en hardhout</li> </ul> | <ul style="list-style-type: none"> <li>• Lange standtijd bij uitstekende snijkwaliteit in massief hout</li> </ul> | <ul style="list-style-type: none"> <li>• Verpakkingseenheid 10 stuks</li> </ul> |

| Producteigenschappen |        |        |          |        |             |               | Bestelinformatie |   |              |
|----------------------|--------|--------|----------|--------|-------------|---------------|------------------|---|--------------|
| B [mm]               | H [mm] | S [mm] | Ø d [mm] | L [mm] | Wighoek [°] | Snijmateriaal | VE [St.]         | V | Bestelnummer |
| 30                   | 12     | 1,5    | 4,0      | 14     | 55          | TC05          | 10               |   | 50820030     |
| 40                   | 12     | 1,5    | 4,0      | 26     | 55          | TC05          | 10               |   | 50820040     |
| 50                   | 12     | 1,5    | 4,0      | 26     | 55          | TC05          | 10               |   | 50820050     |
| 60                   | 12     | 1,5    | 4,0      | 26     | 55          | TC05          | 10               |   | 50820060     |

**HW**

**Omkeermessen**

Fijnste korrelkwaliteit voor grootste standtijd

Product Tekening Machine Toepassing Uitvoering

**LONG LIFE**

**HW TC02**

|                              |  |   |  |
|------------------------------|--|---|--|
| Machine / gebruiksaanwijzing | Uitvoering <ul style="list-style-type: none"> <li>• Snijmateriaal HW</li> <li>• TC02 voor langere standtijd</li> </ul> | Voordelen <ul style="list-style-type: none"> <li>• Lange standtijd bij uitstekende snijkwaliteit in plaatmateriaal op basis van hout</li> </ul> | Informatie - Tip <ul style="list-style-type: none"> <li>• Verpakkingseenheid 10 stuks</li> </ul> |
|------------------------------|--|---|--|

| Producteigenschappen |        |        |          |        |             |               | Bestelinformatie |          |   |              |
|----------------------|--------|--------|----------|--------|-------------|---------------|------------------|----------|---|--------------|
| B [mm]               | H [mm] | S [mm] | Ø d [mm] | L [mm] | Wighoek [°] | Snijmateriaal |                  | VE [St.] | V | Bestelnummer |
| 30                   | 12     | 1.5    | 4,0      | 14     | 55          | TC02          |                  | 10       |   | 50450100     |
| 50                   | 12     | 1.5    | 4,0      | 26     | 55          | TC02          |                  | 10       |   | 50450101     |

**HW**

**Omkeermessen**

Fijnste korrelkwaliteit voor plaatmaterialen

Product Tekening Machine Toepassing Uitvoering

**HW TC06**

|                              |   |   |  |
|------------------------------|---|---|--|
| Machine / gebruiksaanwijzing | Uitvoering <ul style="list-style-type: none"> <li>• Snijmateriaal HW</li> <li>• TC06 voor plaatmateriaal op basis van hout</li> </ul> | Voordelen <ul style="list-style-type: none"> <li>• Lange standtijd bij uitstekende snijkwaliteit in massief hout</li> </ul> | Informatie - Tip <ul style="list-style-type: none"> <li>• Verpakkingseenheid 10 stuks</li> </ul> |
|------------------------------|---|---|--|

| Producteigenschappen |        |        |          |        |             |               | Bestelinformatie |          |   |              |
|----------------------|--------|--------|----------|--------|-------------|---------------|------------------|----------|---|--------------|
| B [mm]               | H [mm] | S [mm] | Ø d [mm] | L [mm] | Wighoek [°] | Snijmateriaal |                  | VE [St.] | V | Bestelnummer |
| 30                   | 12     | 1.5    | 4,0      | 14     | 55          | TC06          |                  | 10       | # | 50450170     |
| 50                   | 12     | 1.5    | 4,0      | 26     | 55          | TC06          |                  | 10       | s | 50450171     |
| 60                   | 12     | 1.5    | 4,0      | 26     | 55          | TC06          |                  | 10       | s | 50450172     |

## HW Omkeermessen Met sleufgat

Product Tekening Machine Toepassing Uitvoering

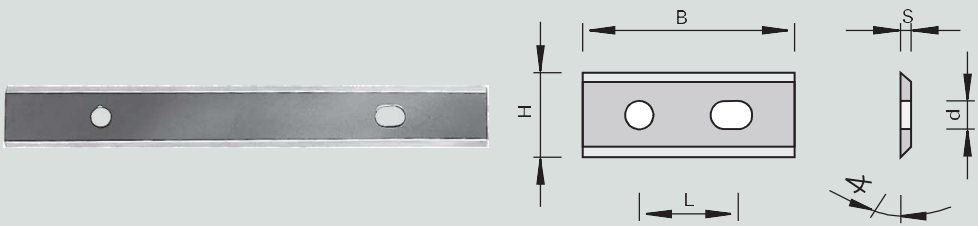



2  
 HW  
**TC06**

|                              |   |   |  |
|------------------------------|---|---|--|
| Machine / gebruiksaanwijzing | Uitvoering <ul style="list-style-type: none"> <li>• Snijmateriaal HW</li> <li>• TC06 voor plaatmateriaal op basis van hout</li> <li>• Met sleufgat</li> </ul> | Voordelen <ul style="list-style-type: none"> <li>• Lange standtijd bij uitstekende snijkwaliteit in massief hout</li> </ul> | Informatie - Tip <ul style="list-style-type: none"> <li>• Verpakkingseenheid 10 stuks</li> </ul> |
|------------------------------|---|---|--|

| Producteigenschappen |        |        |          |        |             |               | Bestelinformatie |          |   |              |
|----------------------|--------|--------|----------|--------|-------------|---------------|------------------|----------|---|--------------|
| B [mm]               | H [mm] | S [mm] | Ø d [mm] | L [mm] | Wighoek [°] | Snijmateriaal |                  | VE [St.] | V | Bestelnummer |
| 80                   | 13     | 2.2    | 4.0      | 60     | 55          | TC06          |                  | 10       |   | 50820080     |
| 100                  | 13     | 2.2    | 4.0      | 60     | 55          | TC06          |                  | 10       | s | 50820100     |
| 120                  | 13     | 2.2    | 4.0      | 60     | 55          | TC06          |                  | 10       | s | 50820120     |

## HW Omkeermessen Kopzijde vrijgeslepen

Product Tekening Machine Toepassing Uitvoering

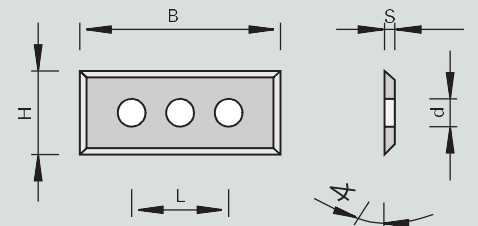



4  
 HW  
**TC05**

|                              |   |           |  |
|------------------------------|---|-----------|--|
| Machine / gebruiksaanwijzing | Uitvoering <ul style="list-style-type: none"> <li>• Snijmateriaal HW</li> <li>• TC05 voor plaatmateriaal op basis van hout, kunststoffen en hardhout</li> </ul> | Voordelen | Informatie - Tip <ul style="list-style-type: none"> <li>• Verpakkingseenheid 10 stuks</li> </ul> |
|------------------------------|---|-----------|--|

| Producteigenschappen |        |        |          |        |             |               | Bestelinformatie |          |   |              |
|----------------------|--------|--------|----------|--------|-------------|---------------|------------------|----------|---|--------------|
| B [mm]               | H [mm] | S [mm] | Ø d [mm] | L [mm] | Wighoek [°] | Snijmateriaal |                  | VE [St.] | V | Bestelnummer |
| 50                   | 12     | 1.7    | 4.0      | 37     | 55          | TC05          |                  | 10       |   | 50450121     |

**HW**

**Omkeermessen**

Voor keermes bovenfrezes kopzijde vrijgeslepen

|         |          |         |            |                    |
|---------|----------|---------|------------|--------------------|
| Product | Tekening | Machine | Toepassing | Uitvoering         |
|         |          |         |            | <p>HW<br/>TC05</p> |

|   |  |           |   |
|---|--|-----------|---|
| Machine / gebruiksaanwijzing  | Uitvoering   | Voordelen | Informatie - Tip  |
| <ul style="list-style-type: none"> <li>Voor toepassing bij keermes bovenfrezes</li> </ul> | <ul style="list-style-type: none"> <li>Snijmateriaal HW</li> <li>TC05 voor plaatmateriaal op basis van hout, kunststoffen en hardhout</li> </ul> |           | <ul style="list-style-type: none"> <li>Verpakkingseenheid 10 stuks</li> </ul> |

| Producteigenschappen |        |        |          |        |             |               | Bestelinformatie |          |   |              |
|----------------------|--------|--------|----------|--------|-------------|---------------|------------------|----------|---|--------------|
| B [mm]               | H [mm] | S [mm] | Ø d [mm] | L [mm] | Wighoek [°] | Snijmateriaal |                  | VE [St.] | V | Bestelnummer |
| 29,5                 | 12     | 1,5    | 4,0      | 14     | 55          | TC05          |                  | 10       | s | 50825004     |

**HW**

**Omkeermessen**

Met fase - HOLZ-HER



|         |          |         |            |                    |
|---------|----------|---------|------------|--------------------|
| Product | Tekening | Machine | Toepassing | Uitvoering         |
|         |          |         |            | <p>HW<br/>TC06</p> |

|   |   |           |   |
|---|---|-----------|---|
| Machine / gebruiksaanwijzing  | Uitvoering  | Voordelen | Informatie - Tip  |
| <ul style="list-style-type: none"> <li>Machines HOLZ-HER</li> <li>Voor toepassing bij kantfreesvoegenfreesmessenkoppen</li> </ul> | <ul style="list-style-type: none"> <li>Spaanhoek 55 graden</li> <li>Snijmateriaal HW</li> <li>TC06 voor plaatmateriaal op basis van hout, kunststoffen en hardhout</li> </ul> |           | <ul style="list-style-type: none"> <li>Verpakkingseenheid 10 stuks</li> </ul> |

| Producteigenschappen |        |        |        |          |        |               | Bestelinformatie |          |   |               |   |               |
|----------------------|--------|--------|--------|----------|--------|---------------|------------------|----------|---|---------------|---|---------------|
| Afkanthoek [°]       | B [mm] | H [mm] | S [mm] | Ø d [mm] | L [mm] | Snijmateriaal |                  | VE [St.] | V | Bestelnr. [L] | V | Bestelnr. [R] |
| 15                   | 29,5   | 12     | 1,5    | 4,0      | 14     | TC06          |                  | 10       |   | 50450290      |   | 50450291      |

## HW Omkeermessen

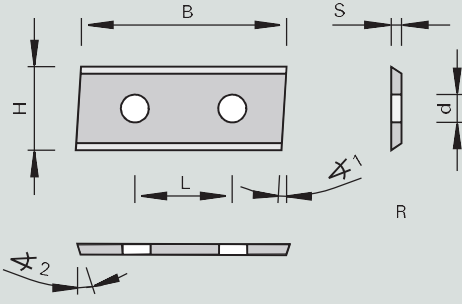

Kopzijde schuin en vrijgeslepen

|  |  |                |   |  |
|--|--|----------------|---|--|
| <p>Product</p>  | <p>Tekening</p>  | <p>Machine</p> | <p>Toepassing</p>  | <p>Uitvoering</p>  <p>HW<br/>TC05</p> |
|--|--|----------------|---|--|

|  |   |                  |   |
|--|---|------------------|---|
| <p>Machine / gebruiksaanwijzing</p> <ul style="list-style-type: none"> <li>Voor toepassing bij kantfijneer- en sponningfrezen</li> </ul> | <p>Uitvoering</p> <ul style="list-style-type: none"> <li>Spaanhoek 55 graden</li> <li>Snijmateriaal HW</li> <li>TC05 voor plaatmateriaal op basis van hout, kunststoffen en hardhout</li> </ul> | <p>Voordelen</p> | <p>Informatie - Tip</p> <ul style="list-style-type: none"> <li>Verpakkingseenheid 10 stuks</li> </ul> |
|--|---|------------------|---|

| Producteigenschappen |        |        |          |        |                    |                    |               | Bestelinformatie |   |               |   |               |  |
|----------------------|--------|--------|----------|--------|--------------------|--------------------|---------------|------------------|---|---------------|---|---------------|--|
| B [mm]               | H [mm] | S [mm] | Ø d [mm] | L [mm] | Vrijloophoek 1 [°] | Vrijloophoek 2 [°] | Snijmateriaal | VE [St.]         | V | Bestelnr. [L] | V | Bestelnr. [R] |  |
| 19,5                 | 12     | 1,5    | 4,0      |        | 3,5                | 10                 | TC05          | 10               | o | 50450241      | o | 50450242      |  |
| 29,5                 | 12     | 1,5    | 4,0      | 14     | 5                  |                    | TC05          | 10               |   | 50450250      |   | 50450251      |  |
| 49,2                 | 12     | 1,5    | 4,0      | 26     | 5                  |                    | TC05          | 10               |   | 50450252      |   | 50450253      |  |

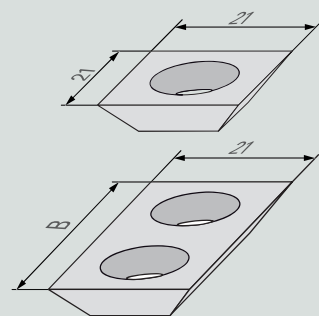
## HW Omkeermessen





|                |   |                |   |   |
|----------------|---|----------------|---|---|
| <p>Product</p> | <p>Tekening</p>  | <p>Machine</p> | <p>Toepassing</p>  | <p>Uitvoering</p>  |
|----------------|---|----------------|---|---|

|  |   |                  |                         |
|--|---|------------------|-------------------------|
| <p>Machine / gebruiksaanwijzing</p> <ul style="list-style-type: none"> <li>Voor toepassing in freeskoppen</li> </ul> | <p>Uitvoering</p> <ul style="list-style-type: none"> <li>Snijmateriaal HW</li> <li>TCw30 voor hard- en zachthout</li> </ul> | <p>Voordelen</p> | <p>Informatie - Tip</p> |
|--|---|------------------|-------------------------|

| Producteigenschappen              |                    | Bestelinformatie |          |   |              |
|-----------------------------------|--------------------|------------------|----------|---|--------------|
|                                   |                    | Snijmateriaal    | VE [St.] | V | Bestelnummer |
| HWM221 omkeermessen HW (hardhout) | 21x21x5,5 4 snedig | TCw30            | 10       |   | 186668       |
| HWM222 omkeermessen HW (hardhout) | 30x21x5,5 4 snedig | TCw30            | 6        |   | 50651530     |
| HWM223 omkeermessen HW (hardhout) | 40x21x5,5 2 snedig | TCw30            | 6        |   | 50651540     |
| HWM224 omkeermessen HW (hardhout) | 50x21x5,5 2 snedig | TCw30            | 6        |   | 50651550     |

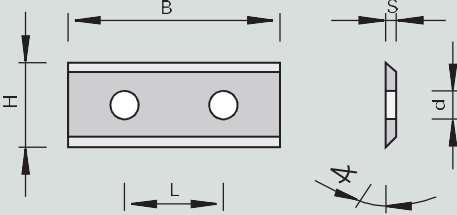
## HW Ruimer-omkeermessen





Fijnste korrelkwaliteit voor massief hout

|   |  |         |   |   |
|---|--|---------|---|---|
| Product   | Tekening   | Machine | Toepassing  | Uitvoering  |
|  |  |         |  | <br><br><b>LONG LIFE</b><br><b>HW TCw20</b> |

|                              |   |   |   |
|------------------------------|---|---|---|
| Machine / gebruiksaanwijzing | Uitvoering  | Voordelen   | Informatie - Tip  |
|                              | <ul style="list-style-type: none"> <li>• Snijmateriaal HW</li> <li>• TCw20 voor massief hout</li> </ul> | <ul style="list-style-type: none"> <li>• Lange standtijd bij uitstekende snijkwaliteit in massief hout</li> </ul> | <ul style="list-style-type: none"> <li>• Verpakkingseenheid 10 stuks</li> </ul> |

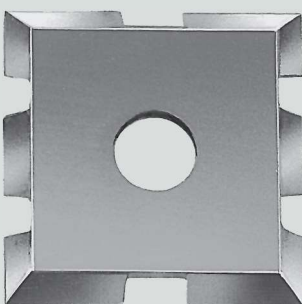
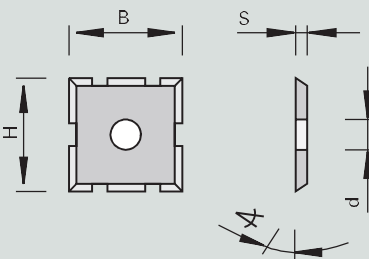
| Producteigenschappen |        |        |          |        |             |               | Bestelinformatie |          |   |              |
|----------------------|--------|--------|----------|--------|-------------|---------------|------------------|----------|---|--------------|
| B [mm]               | H [mm] | S [mm] | Ø d [mm] | L [mm] | Wighoek [°] | Snijmateriaal |                  | VE [St.] | V | Bestelnummer |
| 30                   | 12     | 1.5    | 4,0      | 14     | 45          | TCw20         |                  | 10       |   | 50450080     |
| 40                   | 12     | 1.5    | 4,0      | 26     | 45          | TCw20         |                  | 10       |   | 50450081     |
| 50                   | 12     | 1.5    | 4,0      | 26     | 45          | TCw20         |                  | 10       |   | 50450082     |
| 60                   | 12     | 1.5    | 4,0      | 26     | 45          | TCw20         |                  | 10       |   | 50450083     |





## HW Ruimer-omkeermessen

|   |  |         |   |  |
|---|--|---------|---|--|
| Product   | Tekening   | Machine | Toepassing  | Uitvoering   |
|  |  |         |  | <br><br><b>HW TCw20</b><br> |

|                              |   |           |   |
|------------------------------|---|-----------|---|
| Machine / gebruiksaanwijzing | Uitvoering  | Voordelen | Informatie - Tip  |
|                              | <ul style="list-style-type: none"> <li>• Spaanbreker voor gunstige snijverdeling</li> <li>• Snijmateriaal HW</li> <li>• TCw20 voor hard- en zacht hout</li> </ul> |           | <ul style="list-style-type: none"> <li>• Verpakkingseenheid 10 stuks</li> </ul> |

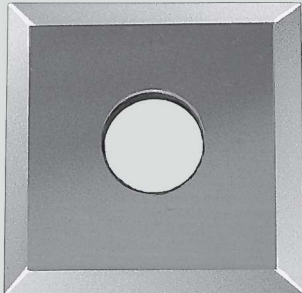
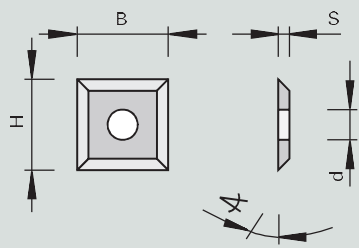
| Producteigenschappen |        |        |          |  |             |               | Bestelinformatie |          |   |              |
|----------------------|--------|--------|----------|--|-------------|---------------|------------------|----------|---|--------------|
| B [mm]               | H [mm] | S [mm] | Ø d [mm] |  | Wighoek [°] | Snijmateriaal |                  | VE [St.] | V | Bestelnummer |
| 15                   | 15     | 2.0    | 4,0      |  | 55          | TCw20         |                  | 10       | o | 50450230     |





## HW Omkeermessen - Voorsnijders

|   |   |   |   |   |
|---|---|---|---|---|
| Product   | Tekening  | Machine   | Toepassing  | Uitvoering  |
|  |  |  |  |  |

|                              |   |           |   |
|------------------------------|---|-----------|---|
| Machine / gebruiksaanwijzing | Uitvoering  | Voordelen | Informatie - Tip  |
|                              | <ul style="list-style-type: none"> <li>• Snijmateriaal HW</li> <li>• TC03 voor plaatmateriaal op basis van hout en kunststoffen</li> <li>• TC05 voor plaatmateriaal op basis van hout, kunststoffen en hardhout</li> <li>• TCwTCw30 voor hard- en zacht hout</li> <li>• TCw40 voor hard- en zacht hout</li> </ul> |           | <ul style="list-style-type: none"> <li>• Verpakkingseenheid 10 stuks</li> </ul> |

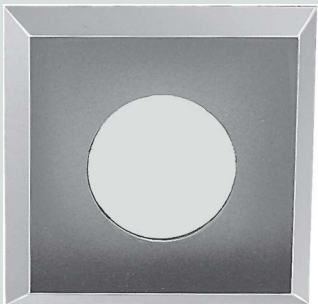
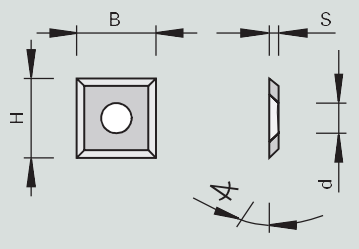
| Producteigenschappen |        |        |          |             |               |  | Bestelinformatie |   |              |
|----------------------|--------|--------|----------|-------------|---------------|--|------------------|---|--------------|
| B [mm]               | H [mm] | S [mm] | Ø d [mm] | Wighoek [°] | Snijmateriaal |  | VE [St.]         | V | Bestelnummer |
| 10,5                 | 10,5   | 1,5    | 4,0      | 55          | TCw30         |  | 10               |   | 50450180     |
| 12                   | 12     | 1,5    | 4,0      | 55          | TC05          |  | 10               |   | 50820012     |
| 12                   | 12     | 1,5    | 4,0      | 55          | TC03          |  | 10               |   | 50450026     |
| 14                   | 14     | 2,0    | 6,3      | 60          | TCw30         |  | 10               |   | 50820014     |
| 17                   | 17     | 2,0    | 4,0      | 35          | TC05          |  | 10               |   | 50450212     |
| 19                   | 19     | 2,0    | 4,0      | 55          | TC05          |  | 10               |   | 50450213     |

## HW Omkeermessen Met verzonken gat

|   |   |   |   |   |
|---|---|---|---|---|
| Product   | Tekening  | Machine   | Toepassing  | Uitvoering  |
|  |  |  |  |  |

|  |   |           |   |
|--|---|-----------|---|
| Machine / gebruiksaanwijzing   | Uitvoering  | Voordelen | Informatie - Tip  |
| <ul style="list-style-type: none"> <li>• Voor toepassing in freeskoppen</li> </ul> | <ul style="list-style-type: none"> <li>• Snijmateriaal HW</li> <li>• TCw25 voor hard- en zacht hout</li> <li>• TCw40 voor hard- en zacht hout</li> <li>• ook gewelfde uitvoering R= 50</li> </ul> |           | <ul style="list-style-type: none"> <li>• Verpakkingseenheid 10 stuks</li> </ul> |



| Producteigenschappen |        |        |          |             |               |                                    | Bestelinformatie |    |              |
|----------------------|--------|--------|----------|-------------|---------------|------------------------------------|------------------|----|--------------|
| B [mm]               | H [mm] | S [mm] | Ø d [mm] | Wighoek [°] | Snijmateriaal |                                    | VE [St.]         | V  | Bestelnummer |
| 13,6                 | 13,6   | 2,0    | 6,3      | 45          | TCw40         | Fischer Brugg                      |                  | 10 | 50450181     |
| 14                   | 14     | 1,2    | 8,6      | 60          | TCw30         |                                    |                  | 10 | 50450182     |
| 14,3                 | 14,3   | 2,5    | 6,3      | 55          | TCw20         | Homag                              |                  | 10 | 50450186     |
| 15                   | 15     | 2,5    | 6,4      | 60          | TCw20         | gewelfd (R=50 mm voor Ø d<100 mm ) |                  | 10 | 50820017     |

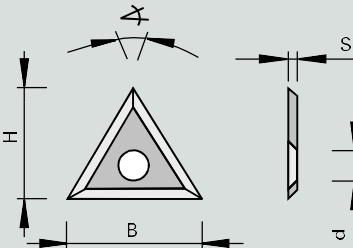

## HW Driehoek-voorsnijders

Product Tekening Machine Toepassing Uitvoering



3

HW  
TCw20



|  |  |                  |   |
|--|--|------------------|---|
| <p>Machine / gebruiksaanwijzing</p> <ul style="list-style-type: none"> <li>Voor toepassing in freeskoppen</li> </ul> | <p>Uitvoering</p> <ul style="list-style-type: none"> <li>Snijmateriaal HW</li> <li>TCw20 voor hard- en zacht hout</li> </ul> | <p>Voordelen</p> | <p>Informatie - Tip</p> <ul style="list-style-type: none"> <li>Verpakkingseenheid 10 stuks</li> </ul> |
|--|--|------------------|---|

| Producteigenschappen |        |        |          |              |               |  | Bestelinformatie |                |  |
|----------------------|--------|--------|----------|--------------|---------------|--|------------------|----------------|--|
| B [mm]               | H [mm] | S [mm] | Ø d [mm] | Tandhoek [°] | Snijmateriaal |  | VE [St.]         | V Bestelnummer |  |
| 22                   | 19.05  | 2.0    | 6,5      | 60           | TCw20         |  | 10               | 50450190       |  |

## HW Groefmessen

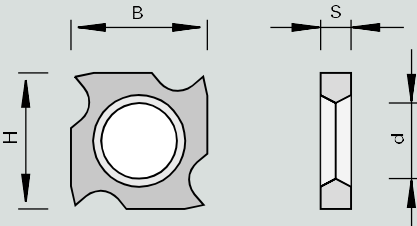
Product Tekening Machine Toepassing Uitvoering



4

HW  
TCw20

|  |  |                  |  |
|--|--|------------------|--|
| <p>Machine / gebruiksaanwijzing</p> <ul style="list-style-type: none"> <li>Voor toepassing in groeffrezen</li> </ul> | <p>Uitvoering</p> <ul style="list-style-type: none"> <li>Snijmateriaal HW</li> <li>TCw20 voor plaatmateriaal op basis van hout, hard- en zacht hout</li> </ul> | <p>Voordelen</p> | <p>Informatie - Tip</p> <ul style="list-style-type: none"> <li>Bestelnummer 50450220 voor groefbreedte 4 mm</li> <li>Bestelnummer 50450221 voor groefbreedte 5 mm</li> <li>Bestelnummer 50450223 voor groefbreedte &gt; 7 mm</li> <li>Verpakkingseenheid 10 stuks</li> </ul> |
|--|--|------------------|--|

| Producteigenschappen |        |        |          |  |               |  | Bestelinformatie |                |  |
|----------------------|--------|--------|----------|--|---------------|--|------------------|----------------|--|
| B [mm]               | H [mm] | S [mm] | Ø d [mm] |  | Snijmateriaal |  | VE [St.]         | V Bestelnummer |  |
| 18                   | 18     | 1.95   | 10       |  | TCw20         |  | 10               | 50450220       |  |
| 18                   | 18     | 2.5    | 10       |  | TCw20         |  | 10               | 50450221       |  |
| 18                   | 18     | 3.7    | 10       |  | TCw20         |  | 10               | 50450223       |  |

## HW Mini-omkeermessen

Met kruisgroef in rugzijde

|         |          |         |            |                        |
|---------|----------|---------|------------|------------------------|
| Product | Tekening | Machine | Toepassing | Uitvoering             |
|         |          |         |            | <br><br><b>HW TC05</b> |

|   |  |           |   |
|---|--|-----------|---|
| Machine / gebruiksaanwijzing  | Uitvoering   | Voordelen | Informatie - Tip  |
| <ul style="list-style-type: none"> <li>Voor toepassing bij keermes bovenfrezen</li> </ul> | <ul style="list-style-type: none"> <li>Snijmateriaal HW</li> <li>TC05 voor plaatmateriaal op basis van hout, kunststoffen en hardhout</li> </ul> |           | <ul style="list-style-type: none"> <li>Verpakkingseenheid 10 stuks</li> </ul> |



| Producteigenschappen |        |        | Bestelinformatie |   |              |
|----------------------|--------|--------|------------------|---|--------------|
| B [mm]               | H [mm] | S [mm] | VE [St.]         | V | Bestelnummer |
| 20                   | 4.1    | 1.1    | 10               |   | 50450150     |
| 20                   | 5.5    | 1.1    | 10               | # | 50450151     |
| 25                   | 5.5    | 1.1    | 10               |   | 50450152     |
| 30                   | 5.5    | 1.1    | 10               |   | 50450153     |
| 40                   | 5.5    | 1.1    | 10               | s | 50450154     |
| 50                   | 5.5    | 1.1    | 10               |   | 50450155     |

## HW Handschaaf-omkeermessen



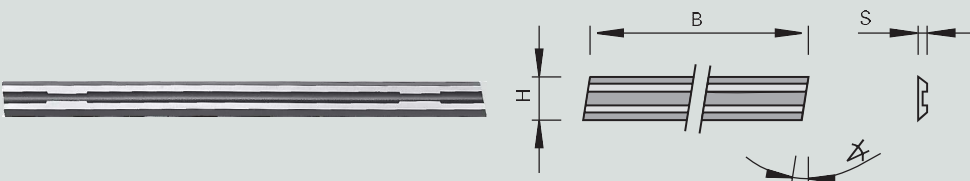

### Kopzijde schuin

Product Tekening Machine Toepassing Uitvoering



|  |   |                  |   |
|--|---|------------------|---|
| <p>Machine / gebruiksaanwijzing</p> <ul style="list-style-type: none"> <li>• Handschaafmachines</li> </ul> | <p>Uitvoering</p> <ul style="list-style-type: none"> <li>• Snijmateriaal HW</li> <li>• TCw40 voor hard- en zachthout</li> </ul> | <p>Voordelen</p> | <p>Informatie - Tip</p> <ul style="list-style-type: none"> <li>• Bestelnr. 50400212 kan alleen in het originele ELU- opspanelement worden gezet</li> <li>• Minimale bestelhoeveelheid 10 stuks = 5 Sets</li> <li>• Verpakkingseenheid 2 stuks op Stehle-skin</li> </ul> |
|--|---|------------------|---|

| Producteigenschappen |        |        |                    | Bestelinformatie  |   |   |              |
|----------------------|--------|--------|--------------------|---|---|---|--------------|
| B [mm]               | H [mm] | S [mm] | Vrijloophoek 1 [°] |   | VE [St.]  | V | Bestelnummer |
| 75,5                 | 5,5    | 1,1    | 1,5                | AEG HTH 75, Bosch 0590, P400, 1590, 1591, Festo REP 75, Haffner FH 222, HOLZ-HER 2223, 2286, 2320, Kress Jet Star 6701, Mafell HU 75, Metabo 6375, Scheer MH 80, MH 75/3, Skil 98 H |  | 2 | o 58400210   |
| 80,5                 | 5,9    | 1,2    | 8                  | ELU MFF 80  |  | 2 | 58400212     |
| 82                   | 5,5    | 1,1    | 3                  | AEG, Fein, Haffner, Hitachi, Mafell, Makita, Metabo, Bosch  |  | 2 | 58400214     |
| 102                  | 5,5    | 1,1    | 3                  | AEG EH 102, HB 750  |  | 2 | o 50400215   |

# ABRASIEF

## GEBRUIKSADVIEZEN

- 1 Gereedschappen die zijn aangeduid met een  in de kop van de productentabel zijn in principe geschikt voor gebruik bij abrasieve materialen.
- 2 Acrylgebonden minerale vezelplaten (synthetisch marmer) kunnen met HW en DP worden bewerkt. De rentabiliteit moet bepalend zijn voor de selectie.
- 3 Bij materialen met grote minerale deeltjes heeft HW de voorkeur vanwege de kans op breuk op de snijkant.
- 4 Bewerkingsadviezen voor geselecteerde materialen. (De formules hiervoor en andere aanwijzingen staan in de Inleiding: „Technische bijlage“.

- **Snij snelheid  $V_c$ :**
  - ▶ Cementvezelplaat: 40 – 60 m/s
  - ▶ Gipsvezelplaat: 40 – 65 m/s
  - ▶ Gipskartonplaat: 45 – 65 m/s
  - ▶ HPL: 50 – 70 m/s
  - ▶ GFK: 20 – 50 m/s

- **Aanvoer per tand  $f_z$ / zagen:**
  - ▶ Cementvezelplaat: 0,02 – 0,05 mm
  - ▶ Gipsvezelplaat: 0,1 – 0,25 mm
  - ▶ Duroplasten: 0,03 – 0,05 mm
  - ▶ Acrylgebonden minerale vezelplaat: 0,03 – 0,05 mm
  - ▶ GFK: 0,01 – 0,03 mm

- **Aanvoer per tand  $f_z$ :**
  - ▶ Schachtfrezen: > Zagen
  - ▶ Sponningfrezen: Schachtfrezen

- **Let ook op de adviezen voor andere invloeden op  $V_c$  en  $f_z$  in de Inleiding „Algemene bewerkingsadviezen“ vanwege de materialen zelf, de keuze van de gereedschappen en de toestand van de machine. Deze helpen om te definiëren of u meer in de richting moet gaan van het onderste of bovenste deel van het bereik.**

- 5 Als de optimale bewerkingsparameters niet bekend zijn is het raadzaam de moeilijkst te bewerken component, gewoonlijk de meest abrasieve component, als richtlijn te nemen.

# BOUW

## GEBRUIKSADVIEZEN

- 1 Gereedschappen die zijn aangeduid met een  in de kop van de productentabel zijn in principe geschikt voor gebruik in de bouw. Zagen die volgens het kleurensysteem met oranje op de verpakking zijn aangeduid zijn geschikt voor vervuilde materialen, hout met spijkers etc.,
- 2 De berekening van de  $V_c$  en  $f_z$  voor handmachines is niet bijzonder praktisch omdat deze machines gewoonlijk worden gebruikt met een handmatige aanvoer en de parameters (bijv. het toerental) niet instelbaar zijn. Hier geldt nog meer het principe van het „zoeken en proberen” en van het „goede gevoel”, omdat de gebruiker van de machine de snijdruk en het geluidsniveau direct kan voelen. Daarom staan er in de inleiding slechts enkele concrete gebruiksparemeters. Toch gelden ook hier de principes zoals genoemd in de betreffende hoofdstukinleiding.
- 3 Bij de bewerking van zachte materialen voor isolatie en geluidsisolatie moeten gereedschappen met groot aantal tanden gekozen worden.
- 4 Gasbetonelementen kunnen goed met DP-handcirkelzaagbladen worden bewerk.
- 5 Snijnsnelheid  $V_c$ :
 

|   |
|---|
| • Hoe harder het te bewerken materiaal, des te lager de $V_c$   |
| • Hoe zachter het te bewerken materiaal, des te hoger de $V_c$  |
| • Daarvan afwijkende voorbeelden: <ul style="list-style-type: none"> <li>▶ Steenwolplaten: 2 – 8 m/s</li> </ul> |
- 6 Als de optimale bewerkingsparameters niet bekend zijn is het raadzaam de moeilijkst te bewerken component, 2) „gewoonlijk de meest abrasieve component, als richtlijn te nemen.

**1** Massief hout is de basis van de houtverwerkende sector. Met enkele uitzonderingen betreft het hier gereedschappen voor het bewerken van al gedroogd hout, d.w.z. na het verzagen. Hebt u vragen of wensen aangaande zaagwerk, neem dan contact op met de vakmensen van Stehle.

**2** Gereedschappen die zijn aangeduid met een  in de kop van de productentabel zijn in principe geschikt voor gebruik bij massief hout en vergelijkbare materialen.

**3** Niet in het hoofdstuk en de catalogus vermeld is het zeer uitgebreide minivingerlasprogramma van Stehle voor de productie van massief constructiehout, BSH en platen van massief hout. Neem ook hiervoor contact op met onze specialisten.

**4** Basisbewerkingsadviezen bij massief hout:

- Nat hout bewerken door zagen met een laag aantal tanden (de snijkwaliteit is hier gewoonlijk geen criterium).
- Verlijmd hout (BSH/massief constructiehout) kan worden bewerkt als massief hout.
- De  $f_z$  voor thermohout is als de  $f_z$  voor het oorspronkelijke hout.
- De  $f_z$  voor kurk kan worden ingesteld als voor zachthout.
- Bij langsbewerking moet de  $f_z$  groter worden gekozen dan bij schulpen.
- Doorlopende snedes resulteren in een betere snedekwaliteit in homogene materialen (bijv. afwerken van massief hout) dan onderbroken snedes.
- Meelooptfrezen resulteert vanwege de ontbrekende splijtende werking bij massief hout, vergeleken met tegenlooptfrezen, in een betere oppervlaktekwaliteit, maar geeft meer problemen met de afzuiging en snijdruk (het opgenomen vermogen wordt groter). (Een meelooptende bewerking is bij tafelfrezen niet toegestaan)
- Meelooptfrezen wordt toegepast bij de nabewerking van kanten van massief hout of bij het groeffrezen.

# HOUT

## GEBRUIKSADVIEZEN

- 5** Bewerkingsadviezenvoorgeselecteerde materialen. (De formules hiervoor en andere aanwijzingen staan in de Inleiding: „Technische bijlage“):

|   |
|---|
| <ul style="list-style-type: none"> <li>• <b>Snijnsnelheid <math>V_c</math>:</b> <ul style="list-style-type: none"> <li>▶ Zachthout: 60 – 100 m/s</li> <li>▶ Hardhout: 60 – 100 m/s</li> <li>▶ Exotisch hardhout: 50 – 85 m/s</li> <li>▶ Fineer: 70 – 100 m/s</li> <li>▶ Hoogverdicht hout: 40 – 65 m/s</li> </ul> </li> </ul>   |
| <ul style="list-style-type: none"> <li>• <b>Aanvoer per tand <math>f_z</math>/ zagen:</b> <ul style="list-style-type: none"> <li>▶ Hardhout schulpen: 0,1 – 0,4 mm</li> <li>▶ Hardhout afkorten: 0,05 – 0,09 mm</li> <li>▶ Zachthout               <ul style="list-style-type: none"> <li>Hardhout schulpen: 0,15 – 0,7 mm</li> </ul> </li> <li>▶ Nat zachthout schulpen: 0,3 – 0,9 mm</li> <li>▶ Zachthout afkorten: 0,1 – 0,2 mm</li> </ul> </li> </ul> |
| <ul style="list-style-type: none"> <li>• <b>Aanvoer per tand <math>f_z</math>/ schaafkoppen:</b> <ul style="list-style-type: none"> <li>▶ Afwerkkwaliteit: 1,0 – 1,5 mm</li> <li>▶ Gemiddelde kwaliteit: 1,5 – 2,5 mm</li> <li>▶ Ruwbewerkingskwaliteit: 2,5 – 5,0 mm</li> </ul> </li> </ul>  |
| <ul style="list-style-type: none"> <li>• <b>Aanvoer per tand <math>f_z</math>/ universeelfrezen:</b> <ul style="list-style-type: none"> <li>▶ Afwerkkwaliteit: 1,0 – 1,5 mm</li> <li>▶ Gemiddelde kwaliteit: 1,5 – 2,5 mm</li> <li>▶ Ruwbewerkingskwaliteit: 2,5 – 5,0 mm</li> </ul> </li> </ul>  |
| <ul style="list-style-type: none"> <li>• <b>Aanvoer per tand <math>f_z</math>/CNC-schachtfrezen:</b> <ul style="list-style-type: none"> <li>▶ Massief hout: 0,2 – 0,3 mm</li> </ul> </li> </ul>   |

- 6** Bij composietmaterialen is er vaak sprake van een of meerdere componenten met specifieke eisen. Als de optimale bewerkingsparameters niet bekend zijn is het raadzaam de moeilijkst te bewerken component als richtlijn te nemen. Dit is gewoonlijk niet het massieve hout.

**1** Het be- en verwerken van plaatmateriaal is inmiddels één van de kernpunten in de interieurbouw, winkel- en standbouw en bij de productie van meubelen. Vele machines zijn exact daarvoor ontworpen. Om die reden heeft Stehle in het hoofdstuk Plaat het nieuwe onderdeel kantenbewerking aangemaakt.

**2** Gereedschappen die zijn aangeduid met een  in de kop van de productentabel zijn in principe geschikt voor gebruik bij plaatmateriaal op basis van hout.

**3** Basisbewerkingsadviezen bij plaatmaterialen op basis van hout:

- In principe kunnen platen op basis van hout met HW-gereedschappen bewerkt worden. DP-gereedschappen worden aanbevolen als het te bewerken volume of abrasieve bekledingen of componenten DP economisch maken.
- Door het productieproces komen in plaatmateriaal op basis van hout vaak zand en andere onzuiverheden voor. Daardoor wordt gereedschap sneller stomp. Daarom worden serie-producties steeds vaker met DP-gereedschappen bewerkt.
- Bij plaatmateriaal op basis van hout wordt vanwege een tekort aan grondstoffen steeds vaker oud hout gerecycled. Zulke verontreiniging en andere restanten kunnen bij DP-gereedschap het uitbreken van de snijkant veroorzaken.
- Met doorlopende snedes wordt een betere snijkwaliteit in homogene materialen (MDF) bereikt dan bij onderbroken snedes.
- Bij multiplex moeten de gereedschappen tegelijkertijd voor de langsbewerking en schulpen zijn ontworpen. De messen slijten gewoonlijk door het hoge lijmgehalte.
- Bij bekleed plaatmateriaal op basis van hout is de gereedschapkeuze sterk afhankelijk van de bekledingen.
- Een verbetering van de snijkwaliteit aan de onder- en bovenkant van bekleed plaatmateriaal op basis van hout kan worden bereikt met tegenlopende ashoeken.
- Hoe dunner de bekleding van een plaat op basis van hout, des te meer agressieve tandvormen moeten worden gebruikt bij het zagen, en des te groter moet de ashoek zijn bij freesgereedschappen.



# PLAAT

## GEBRUIKSADVIEZEN

- 4** Bewerkingsadviezen voor geselecteerde materialen. (De formules hiervoor en andere aanwijzingen staan in de Inleiding: „Technische bijlage“):

- **Snijnsnelheid  $V_c$ :**
  - ▶ Tweezijdig gefineerd
 

|             |             |
|-------------|-------------|
| Spaanplaat: | 60 – 90 m/s |
| Multiplex:  | 40 – 65 m/s |
  - ▶ Direct beklede
 

|                      |              |
|----------------------|--------------|
| Melamine-spaanplaat: | 60 – 80 m/s  |
| Ruwe spaanplaat:     | 50 – 80 m/s  |
| Harde vezelplaat:    | 50 – 80 m/s  |
| Zachte vezelplaat:   | 60 – 100 m/s |
  - ▶ Met folie beklede spaanplaat: 60 – 80 m/s
  - ▶ MDF: 60 – 80 m/s
- **Aanvoer per tand  $f_z$ /zagen:**
  - ▶ OSB-plaat: 0,12 – 0,2 mm
  - ▶ Gefineerde plaat: 0,02 – 0,09 mm
  - ▶ Meubelplaat: 0,03 – 0,12 mm
  - ▶ Met melamine beklede spaanplaat: 0,04 – 0,06 mm
  - ▶ HPL-beklede spaanplaat: 0,02 – 0,1 mm
  - ▶ Multiplex: 0,04 – 0,1 mm
  - ▶ Harde vezelplaat: 0,03 – 0,07 mm
  - ▶ HPL-hout: 0,02 – 0,05 mm
- **Aanvoer per tand  $f_z$ /groefgereedschappen:**
  - ▶ Ruwe spaanplaat: 0,4 – 0,75 mm
  - ▶ Gefineerde spaanplaat: 0,1 – 0,15 mm
  - ▶ Beklede spaanplaat: 0,18 – 0,38 mm
  - ▶ Tussenlagen obv. Hout (plex): 0,3 – 0,65 mm
- **Aanvoer per tand  $f_z$ / universeelfrezen:**
  - ▶ Afwerkqualiteit: 1,0 – 1,5 mm
  - ▶ Gemiddelde kwaliteit: 1,5 – 2,5 mm
  - ▶ Ruwbewerkingskwaliteit: 2,5 – 5,0 mm
- **Aanvoer per tand  $f_z$ / CNC-schachtfrezen:**
  - ▶ Massief hout- en fineer- materiaalplaten: 0,2 – 0,3 mm
  - ▶ Houtspaanplaten: 0,25 – 0,35 mm
  - ▶ Houtvezelplaten: 0,25 – 0,3 mm

- 5** Bij composietmaterialen zijn vaak één of meerdere abrasieve of afwijkende opgenomen componenten. Als de optimale bewerkingsparameters niet bekend zijn is het raadzaam de moeilijkste te bewerken componenten als richtlijn te kiezen. Dit is gewoonlijk niet het materiaal van de plaat op basis van hout.

1 Gereedschappen die zijn aangeduid met een  in de kop van de productentabel zijn in principe geschikt voor gebruik bij non-ferrometalen.

2 Basisbewerkingsadviezen bij aluminium en non-ferrometalen:

- Pas op! Bij het verwerken van non-ferrometalen op voor hete spanen.
- Aluminium met een laag percentage silicaat kan met HW-gereedschappen bewerkt worden. Bij een hoger percentage silicaat worden met het oog op de grote slijtage van de messen DP-gereedschappen aanbevolen.
- Met het oog op terugslag moeten bij inzet in aluminium, bij handbediende afkort- en tafelcirkelzagen, zaagbladen met een negatieve spaanhoek gebruikt worden. Een positieve spaanhoek mag alleen worden toegepast als dit op basis van de goede werkstukopspanning en de drukhoek verantwoord is.
- Met doorlopende snedes wordt een betere snedekwaliteit in homogene materialen (aluminium) bereikt dan bij onderbroken snedes.
- De snijsnelheid bij schachtfrezen hangt af van de diameter van de frees; hoe groter de  $\varnothing$  des te hoger de snijsnelheid.
- De snijsnelheid bij schachtfrezen hangt ook af van de soort bewerking. Bij het nabewerken en fijnbewerken moet deze hoger worden ingesteld dan bij het ruw bewerken.
- Bij een high performance-bewerking moet een, in vergelijking met het nabewerken, ong. 12 % hogere snijsnelheid en een beduidend lagere  $f_z$  worden ingesteld.
- Hoe harder geëloxeerd aluminium is, des te  $< f_z$
- Hoe meer verspaanvolume, des te  $< f_z$

# ALUMINIUM

## GEBRUIKSADVIEZEN

**3** Bewerkingsadviezen voor geselecteerde materialen. (De formules hiervoor en andere aanwijzingen staan in de Inleiding: „Technische bijlage“):

- **Snijnsnelheid  $V_c$  / zagen:**
  - ▶ Zuiver aluminium: 60 – 80 m/s
  - ▶ Geëloxeerd aluminium: 40 – 60 m/s
  - ▶ Al-Si-legering: 15 – 40 m/s
- **Snijnsnelheid  $V_c$  / schachtfrezen:**
  - ▶ Zuiver aluminium: 3 – 7,5 m/s
  - ▶ Al-Si-legering (< 10% Si): 6 – 9,5 m/s
  - ▶ Al-Si-legering (< 10% Si): 5 – 8 m/s
  - ▶ Koper/messing/brons: 2,5 – 5,8 m/s
- **Aanvoer per tand  $f_z$  / zagen:**
  - ▶ Alu-kneedlegeringen: 0,02 – 0,1 mm
  - ▶ Aluminium-gietlegering: 0,01 – 0,05 mm
  - ▶ Dunwandige profielen/  
platen (< 2mm): 0,02 – 0,04 mm
  - ▶ Dikwandige profielen/  
platen: 0,04 – 0,18 mm
- **Aanvoer per tand  $f_z$  / groefgereedschappen:**
  - ▶ Non-ferrometalen: 0,02 – 0,05 mm
- **Aanvoer per tand  $f_z$  schachtgereedschappen:**
  - ▶ Zuiver aluminium: 0,12 – 0,3 mm
  - ▶ Al-Si-legering (< 10% Si): 0,01 – 0,3 mm
  - ▶ Al-Si-legering (< 10% Si): 0,02 – 0,3 mm
  - ▶ Koper/messing/brons: 0,03 – 0,24 mm

**4** Bij composietmaterialen maken aluminium of non-ferrometalen in één of andere vorm vaak deel uit van de composiet. Als de optimale bewerkingsparameters niet bekend zijn is het raadzaam de moeilijkst te bewerken component als richtlijn te nemen. Dit is vaak het aluminium. Daarom worden gereedschappen in dit hoofdstuk ook en vooral voor composietmaterialen gebruikt.

# STAAAL

## GEBRUIKSADVIEZEN

- 1 De gereedschappen die genoemd worden in het hoofdstuk Staal zijn niet geschikt voor zuiver metaalverwerkende bedrijven. Ze zijn meer bedoeld voor het bewerken van hout, voor de interieurbouw en de stand- en winkelbouw, waarbij er soms staal of rvs verwerkt moet worden dat in composietmaterialen voor kan komen.
- 2 Enkele zagen kunnen ook gebruikt worden op Dry-cut- en andere afkortmachines, maar ze zijn ontworpen en bedoeld voor bewerkingen op houtbewerkingsmachines.
- 3 IJzerhoudende metalen/staal zijn zonder twijfel de begrenzende factor voor de toepassing van houtbewerkingsgereedschappen. Voor deze gecombineerde toepassing worden dus snijmaterialen en een snijkantgeometrie gekozen die min of meer voldoen aan de eisen voor materialen op basis van hout en ook aan die voor staal.
- 4 Zuiver massief materiaal moet daarmee niet bewerkt worden. De dikte van profielen en plaat mag max. 3 mm zijn.

- 5 Gereedschappen die zijn aangeduid met één   in de kop van de productentabel zijn beperkt geschikt voor gebruik bij staal en rvs.

- 6 Bewerkingsadviezen voor geselecteerde materialen. (De formules hiervoor en andere aanwijzingen staan in de Inleiding: „Technische bijlage“):

- Snijsnelheid  $V_c$  / zagen:
  - ▶ Staal: 40 – 60 m/s
  - ▶ Rvs: 30 – 45 m/s
  - ▶ Ontworpen voor handmatige **aanvoer** (2 – 7 m/min)

- 7 Empfohlene Umdrehungen pro Minute (RPM) für unser Programm:

- empf. 1/min (RPM):
  - ▶ Ø160 = 2750 min-1
  - ▶ Ø190 = 2350 min-1
  - ▶ Ø216 = 2050 min-1
  - ▶ Ø230 = 1950 min-1

- empf. 1/min (RPM):
  - ▶ Ø250 = 1750 min-1
  - ▶ Ø305 = 1500 min-1
  - ▶ Ø355 = 1250 min-1

- 8 Bij composietmaterialen maken staal- of rvs-componenten in de één of andere vorm altijd deel uit van het materiaal. De basisregel om de bewerking af te stemmen op de moeilijkst te bewerken component is hier bijzonder relevant. Bij componenten van staal of rvs zullen deze de doorslaggevende componenten zijn, omdat zuivere houtbewerkingsgereedschappen bij contact met staal gewoonlijk beschadigd raken. Daarom worden de gereedschappen uit dit hoofdstuk ook en speciaal voor composietmaterialen gebruikt.

# KUNSTSTOF

## GEBRUIKSADVIEZEN

- 1 Kunststoffen zijn niet meer weg te denken uit de houtverwerkende sector. Deze komen steeds meer in zuivere vorm en bij composietmaterialen voor.
- 2 Kunststoffen zijn in composietmaterialen vaak zodanig geïntegreerd dat ze op zich niet meer zichtbaar zijn. Denk alleen maar aan de beklede platen of verandaplatten van WPC. Voor bijv. HPL-beklede spaanplaat staan de gebruiksparemeters in het hoofdstuk Plaat, maar ze zijn ook af te leiden van de zuivere vorm in het hoofdstuk Kunststof.
- 3 Kunststoffen kunnen worden onderverdeeld in drie groepen met zeer verschillende bewerkingsvoorwaarden, de thermoplasten, de duroplasten en de elastomeren. Daarbij komen de composietmaterialen met een inmiddels vrijwel grenzenloze verscheidenheid. Niet alleen in combinatie met materialen op basis van hout, metalen, glas, ... maar ook onderling.

- 4 Gereedschappen die zijn aangeduid met een   in de kop van de productentabel zijn in principe geschikt voor gebruik bij kunststoffen (er zijn echter dermate grote verschillen tussen bijv. duro- en thermoplasten dat de gereedschappen niet noodzakelijkerwijze voor beide ideaal zijn).

- 5 Basisbewerkingsadviezen bij kunststoffen::

- Thermoplasten en elastomeren kunnen in principe met HW-gereedschappen bewerkt worden
- Duroplasten kunnen met het oog op hoge slijtage in het algemeen economisch bewerkt worden met DP-gereedschappen.
- Thermoplasten kunnen met een lage snijsnelheid worden bewerkt.
- Zodra kunststoffen bij het bewerken beginnen te vloeien of kleven: toerental verlagen.
- Doorlopende sneden resulteren in een betere snijkwaliteit in homogene materialen, zoals blokken kunststof, dan onderbroken snedes.
- Vezelversterkte kunststoffen (GFK, CFK, AFK) vereisen zeer stabiele gereedschappen. Kies bij schachtfrezen daarom steeds een VHM-uitvoering.
- Bij vezelversterkte kunststoffen (GFK, CFK, AFK) moet het toerental zo mogelijk beduidend worden verlaagd, bij CNC-bewerkingscentra tot 8000 tot 12.000 omw/min.
- Bij het bewerken van polypropyleen (PP) zetten de spanen sterk uit. Daarom moeten er gereedschappen worden gekozen met grote spaanruimtes en weinig tanden.
- Glanzende oppervlakken en massieve materialen als acrylglas (PMMA) kunnen met Monodia-gereedschappen met een optimale finish nabewerkt worden.

- 6** Bewerkingsadviezen voor geselecteerde materialen. (De formules hiervoor en andere aanwijzingen staan in de Inleiding: „Technische bijlage“):

- **Snijnsnelheid  $V_c$ :**
  - ▶ Polycarbonaat/acetaat: 6 – 8 m/s
  - ▶ PVC: 2,5 – 4 m/s
  - ▶ PMMA: 6 – 8 m/s
  - ▶ HPL-platen met massieve kern: 15 – 50 m/s
  - ▶ Fenolhars-materiaal: 1,5 – 3,5 m/s
  - ▶ Multiplexplaten: 50 – 70 m/s
  - ▶ HPL: 50 – 70 m/s
  - ▶ GFK: 20 – 50 m/s
- **Aanvoer per tand  $f_z$  / zagen:**
  - ▶ Thermoplast-volkern-platen: 0,05 – 0,1 mm
  - ▶ HPL-platen met massieve kern: 0,01 – 0,05 mm
  - ▶ Acrylgebonden minerale vezelplaat: 0,03 – 0,05 mm
  - ▶ GFK: 0,01 – 0,03 mm
- **Aanvoer per tand  $f_z$  / groefgereedschappen:**
  - ▶ Thermoplasten: 0,2 – 0,5 mm
  - ▶ Duroplasten: 0,03 – 0,05 mm
- **Aanvoer per tand  $f_z$  / CNC-schachtfrezen:**
  - ▶ Thermoplasten: 0,2 – 0,3 mm
  - ▶ Polycarbonaat/acetaat: 0,12 – 0,6 mm
  - ▶ PVC: 0,12 – 0,6 mm
  - ▶ PMMA: 0,12 – 0,6 mm
  - ▶ Fenolhars-materiaal: 0,12 – 0,6 mm
  - ▶ Bekledingsmateriaal: 0,2 – 0,3 mm
  - ▶ HPL-plaat met massieve kern: 0,2 – 0,3 mm
  - ▶ Acrylgebonden minerale vezelplaat: 0,01 – 0,25 mm
  - ▶ GFK, CFK, AFK: 0,05 – 0,15 mm
  - ▶ Elastomeren: 0,2 – 0,3 mm

- 7** Bij composietmaterialen komen vaak één of meerdere kunststofcomponenten voor. Als de optimale bewerkingsparameters niet bekend zijn is het raadzaam de moeilijkst te bewerken component als richtlijn te nemen. Dit kan zeer wel de kunststof zijn, bijvoorbeeld als er sprake is van GFK-componenten; thermoplasten kunnen smelten of een elastomeer kan uitbreken, in plaats van zuiver gesneden te worden..

# MATERIAALGESCHIKTHEID

|   |   |   |   |   |   |  |   |   |                 |              |
|---|---|---|---|---|---|--|---|---|-----------------|--------------|
|    |    |    |    |    |    |    |    |    | <b>ABRASIEF</b> |              |
|    |    |    |    |    |    |    |    |    |                 | <b>BOUW</b>  |
|    |    |    |    |    |    |    |    |    | <b>HOUT</b>     |              |
|    |    |    |    |    |    |    |    |    |                 |              |
|   |   |   |   |   |   |  |   |   |                 |              |
|  |  |  |  |  |  |  |  |  |                 | <b>PLAAT</b> |
|  |  |  |  |  |  |  |  |  |                 |              |
|  |  |  |  |  |   |  |   |   |                 |              |
|  |  |  |  |  |  |  |  |  | <b>ALU</b>      |              |
|  |  |  |  |  |  |  |  |  | <b>STAAL</b>    |              |
|  |  |  |  |  |  |  |  |  | <b>PLASTIC</b>  |              |





# TECHNISCHE BIJLAGE

# Productinformatie/technische informatie

## 1 SNIJMATERIAAL

### — HARDMETAAL (HW)

- Hardmetaal als snijmateriaal is er in zeer verschillende uitvoeringen, voor diverse toepassingen en materialen. De verschillen betreffen de samenstelling, inclusief het soort bindmiddel, korrelgrootte, dichtheid, hardheid, taatheid en buigvastheid. Het hardmetaal voor Stehle HW-cirkelzaagbladen is voor het bewerken van de betreffende soorten materialen ontworpen en geoptimaliseerd.
- HW-snijmaterialen volgens Stehle-codering beginnen met de afkorting TC. Hierop kan een letter volgen en het eindigt met een tweecijferig getal.

- De volgende basisregels/tendensen zijn van toepassing:

- ▶ Hoe kleiner het getal in de aanduiding, des te harder het snijmateriaal (des te langer de totale standtijd).
- ▶ Hoe hoger het getal, des te hoger de taatheid (des te minder het breukrisico).
- ▶ Hoe fijner de korrelgrootte, des te harder het snijmateriaal en des te hoger de taatheid en de breuktaaiheid.

- Materiaaloriëntatie:

- ▶ De letter „w” in de aanduiding (na TC en voor het getal) betekent „wood” en beschrijft snijmaterialen, speciaal voor massief hout.
- ▶ De letter „m” staat voor metalen (aluminium en staal).
- ▶ „x” staat voor Cermet, een metallurgisch/keramisch composietmateriaal met de keramische voordelen van hardheid en temperatuurbestendigheid. Cermet wordt gebruikt bij bijzonder veeleisende toepassingen in staal.

### — POLYKRISTALLINE DIAMANT (DP)

- DP-messen worden synthetisch geproduceerd. Daarbij wordt de diamantlaag op een dragerlaag van hardmetaal gesinterd. Deze dragerlaag is op de kop van het gereedschap gesoldeerd.
- DP is 2 – 3 keer harder dan hardmetaal. Daardoor wordt in geschikte materialen een veelvoud van de totale standtijd bereikt. Tegelijkertijd is DP door de geringe taatheid veel gevoeliger voor snijkantbreuk dan HW. Daarom is het niet geschikt voor alle materialen.
- Bij spaan- en vezelplaat en bij abrasieve materialen heeft DP zichzelf de afgelopen tientallen jaren bewezen en is daarom door zijn rentabiliteit bij het verwerken van hout niet meer weg te denken.

### — MONOKRISTALLINE DIAMANT (DM)

- DM heeft zeer beperkte toepassingsmogelijkheden in de be- en verwerking van hout, kunststoffen en composietmaterialen.
- Stehle heeft DM-gereedschappen voor de nabewerking van PMMA (acrylglas) op bewerkingscentra in het assortiment.

### — HIGH PERFORMANCE SNELSTAAL (HS)

- Het traditionele snijmateriaal voor de bewerking van massief hout, vooral zachthout. Stehle heeft HS-gereedschappen voor groef- en veer, ronde en geribde drevelstokken en voor vlak- en profielschaven in het assortiment.
- Schaafmessen met longlife-coating bereiken bij geschikte materialen de dubbele tot meervoudige standtijd.

**2** Om een optimale **snijkwaliteit** en **standtijd** te bereiken moeten de bewerkingsparameters worden aangepast aan de te bewerken materialen. Een ervaren machineoperator zal bij het bewerken al „aanvoelen” of de gebruiksparemeters goed zijn. De vorm en grootte van de spanen, trillingen en het geluid zijn bij tot nog toe onbekende materialen vaak eenvoudige mogelijkheden om af te tasten wat mogelijk de optimale toepassing op de betreffende machine zal zijn.

**3** Richtwaarden voor een optimaal resultaat zijn vaak af te leiden van de **snijnsnelheid** en de **aanzet per tand**. Deze zijn afhankelijk van het soort gereedschap (de soort bewerking), de diameter van het gereedschap en het te bewerken materiaal.

Op basis hiervan kunnen de door de machineoperator in te stellen parameters, gewoonlijk het toerental en de aanzet, worden berekend. Bovendien dienen deze als hulp bij de keuze van het gereedschap.

**4** Basis **snijnsnelheid**  $V_c$  (in m/sec):

Uit de snijnsnelheidsberekening volgt het optimale toerental voor een bepaald soort materiaal bij een gegeven gereedschapdiameter.

De formule hiervoor is als volgt:

$$n = \frac{V_c \times 1.000 \times 60}{\pi \times D}$$

- Voorbeeld voor de berekening:

- ▶ te bewerken materiaal: met melamine beklede spaanplaat;  
 $V_c = 60\text{--}80$  m/sec
- ▶ Machine/toepassing: Formaatnsede op tafelcirkelzaag
- ▶ gebruikt gereedschap: cirkelzaagblad, diameter 300 mm
- ▶ Berekening:

$$n = \frac{70 \times 1.000 \times 60}{3,14 \times 300} = 4.458 \text{ 1/min}$$

- ▶ **Resultaat:** Zoals gebruikelijk bij een tafelcirkelzaaginstelling is het ideale toerental voor een uitstekende snedekwaliteit en standtijd ong. 4500 omw/min

- De enige veranderbare variabele bij een gegeven materiaal is de diameter van de gereedschappen.

- Voor de snijnsnelheid gelden geen vaste waarden maar een aanbevolen bandbreedte op basis van ervaringen. Deze staan in de betreffende tabellen. De waarden gelden voor HW-cirkelzaagbladen. Voor HW-freesgereedschappen gelden gewoonlijk 10 – 15% lagere waarden.

- Basisinvloeden voor de  $V_c$ :

- ▶ Hoe harder het te bewerken materiaal, des te lager de  $V_c$
- ▶ Hoe zachter het te bewerken materiaal, des te hoger de  $V_c$

## 5 Basis aanzet per tand $f_z$ (in mm):

Uit de berekening van de aanzet per tand volgt de optimale aanzet  $V_f$  voor een bepaald soort materiaal bij een gegeven toerental en een gegeven aantal tanden. De formule hiervoor is als volgt:

$$V_f = \frac{f_z \times n \times Z}{1.000}$$

- **Voorbeeld voor de berekening:**

- ▶ te bewerken materiaal: Eikenhout massief;  $f_z = 0,2$  mm
- ▶ Machine/toepassing: Groeven maken op CNC-bewerkingscentrum  $n = 18.000$
- ▶ gebruikt gereedschap: cirkelzaagblad, diameter 300 mm
- ▶ Berekening:

$$V_f = \frac{0,2 \times 18.000 \times 2}{1.000} = 7,2 \text{ m/min}$$

- ▶ **Resultaat:** Bij  $z = 2$  wordt een aanzet aanbevolen van ong. 7 m/min. Als er een grotere aanzet gewenst wordt kan dit worden bereikt door een hoger toerental, bijv. 24.000 omw/min. Daarmee zou met een aanzet van 9,6, d.w.z. ong. 10 m/min gefreesd worden bij gelijkblijvende snijkwaliteit en standtijd. Aanvullend (of alternatief) kan een gereedschap met 3 snijkanten gebruikt worden. Dan kan er met ong. 15 m/min worden gefreesd.
- De mogelijke variabelen bij een gegeven materiaal zijn dus het toerental en het aantal snijkanten van het gereedschap. Ideaal gesproken zou het toerental echter vooraf door de snijsnelheidsberekening gedefinieerd moeten zijn.
- Net als bij de snijsnelheid gelden er voor de  $f_z$ 's geen vaste waarden maar een aanbevolen bandbreedte op basis van ervaringen. Deze staan in de betreffende tabellen. In de inleidingen van de hoofdstukken staan adviezen over de  $f_z$  voor de verschillende materialen. Daarnaast staan er adviezen over de factoren die op deze waarden van invloed kunnen zijn.

## 6 Basisinvloeden voor de $f_z$ :





- Binnen een categorie kunnen er duidelijke verschillen zijn, afhankelijk van de materiaal-consistentie; de richtwaarden moeten dus niet als absoluut worden beschouwd.
- Hoe „zwaarder” de bewerking, des te  $< f_z$ .
- Bij composietmaterialen is het meest „abrasieve, hardnekkige, harde” composietmateriaal bepalend voor de  $f_z$ .
- Bij een toenemend  $< f_z$  wordt de standtijd van de snijkant korter.

## 7 Basisinvloeden voor de snijkwaliteit (SG):

- Hoe  $< f_z$  des te  $>$  de snijkwaliteit
- Hoe  $>$  de ashoek van de snijkant des te  $>$  de snijkwaliteit
- Hoe beter de spaanafvoer des te  $>$  de snijkwaliteit (spiraalvormige schachttuitvoering, ashoek en spaangerichte uitvoering beter dan rechte schacht/snijkant)
- Hoe  $<$  de snijdruk des te  $>$  de snijkwaliteit ( $< f_z$ , ashoek,  $>$  spaanhoek en spaanbreker zorgen voor  $<$  snijdruk)
- Bij homogene materialen wordt met doorlopende snedes een betere snijkwaliteit bereikt dan met onderbroken snedes.





# 8 ZAGEN

- DP-zaagbladen kunnen vanwege (in de regel) nauwkeuriger toleranties met een grotere  $f_z$  worden gebruikt dan HW-zaagbladen.
- Bij een grotere materiaaldikte: aantal tanden verminderen.
- Meeneemgaten/Spiebanen:

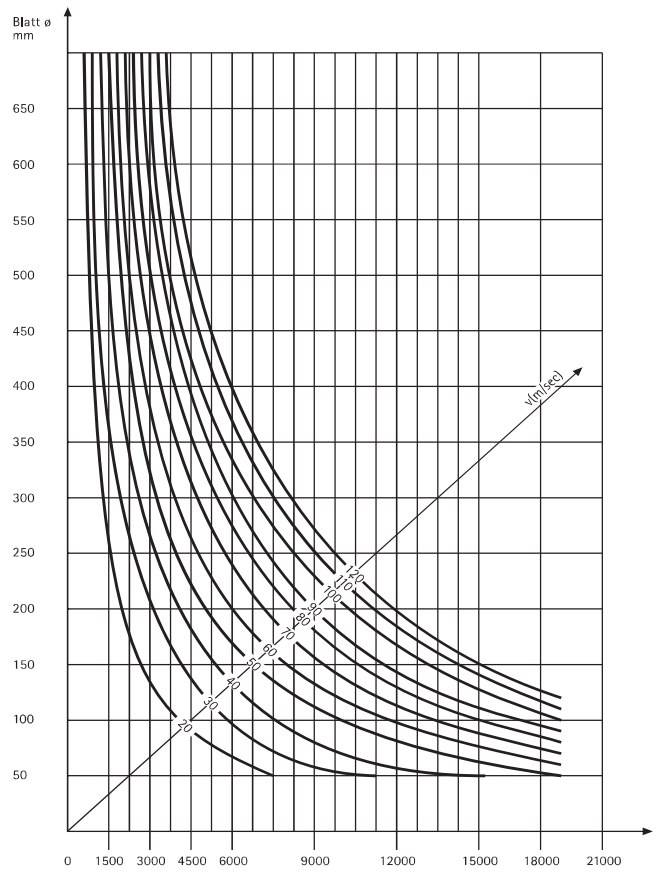
|  |                                    |
|--|------------------------------------|
|   | ** Meeneemgaten<br>voorb.: 2/10/60 |
|   | Combi-Meeneemgaten                 |
|   | Dubbele spiebaan (DKN)             |
|  | Spiebaan (KN)                      |

— Aanbevolen snijsnelheid in m/sec

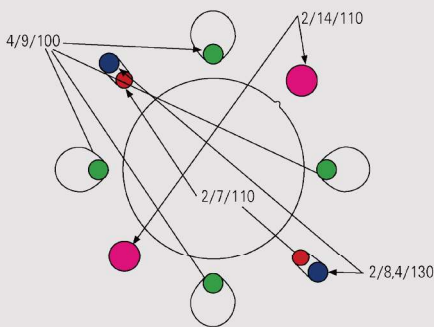
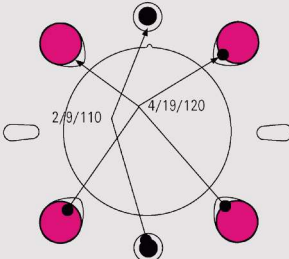
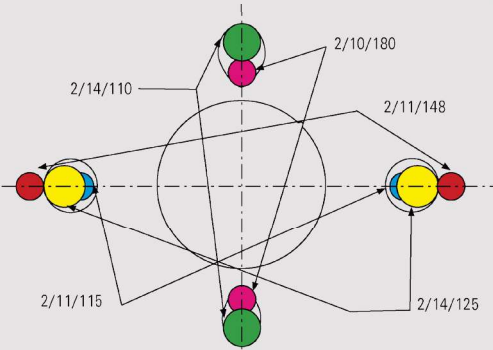
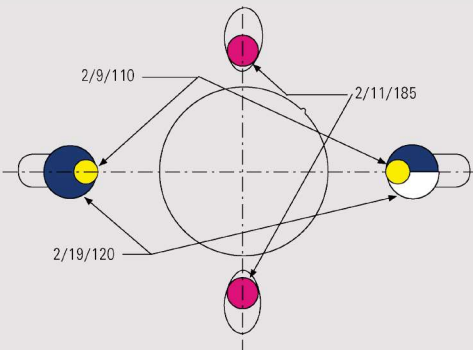

|   |   |  |   |
|---|---|--|---|
| <p><b>COMBI1</b></p>  <p>2/10/60<br/>+ 2/7/742</p> | <p><b>COMBI2</b></p>  <p>2/10/60<br/>+ 2/9/46<br/>+ 2/7/42</p> | <p><b>COMBI3</b></p>  <p>2/10/60<br/>+ 2/9/46<br/>+ 2/9,5/46,5<br/>+ 2/7/42</p> | <p><b>COMBI4</b></p>  <p>2/2/99,5<br/>+ 2/3,3/48</p> |
| <p><b>COMBI5</b></p>                               |   |    |   |
| <p><b>COMBI7</b></p>                               |   |    |   |

— VERZINKEN VAN MEENEEMGATEN

Tanden met de klok mee  
Bovenzijde verzonken  
= Links verzonken

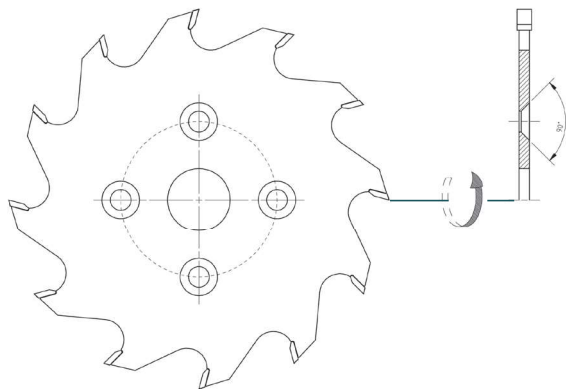

Tanden tegen de klok in  
Bovenzijde verzonken  
= Rechts verzonken

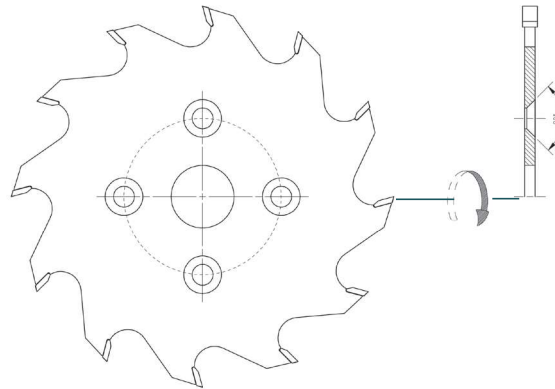

— SPAANHOEK

**Negatieve spaanhoek**

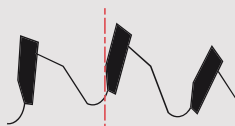

Negatieve spaanhoek: In principe bij afkorten, pendelzagen in hout, materialen op basis van hout, non-ferrometalen en kunststoffen en bij materialen met kans op terugslag bij een goede werkstukopspanning.

**Positieve spaanhoek**

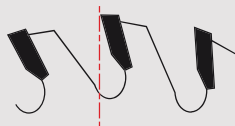

Hoe zachter het materiaal, des te groter de spaanhoek, gewoonlijk 20° bij zachthout langsbewerkt, 15° bij hardhout langsbewerkt, 10° bij plaatmateriaal en schulpen in hout en 8° bij non-ferrometalen en kunststoffen.

— SNIJMATERIAAL

De volgende snijmaterialen worden gebruikt voor de Stehle HW-cirkelzaagbladen:

- Snijmaterialen voor materialen op basis van hout, composietmaterialen en universele toepassing:  
TC03      TC20  
TC04 plus    TC25  
TC06  
TC10

- Snijmateriaal voor massief hout:  
TCw15
- Snijmaterialen voor metaalbewerking:  
TCx03  
TCm17

— KWALITEITSNIVEAU ZAGEN

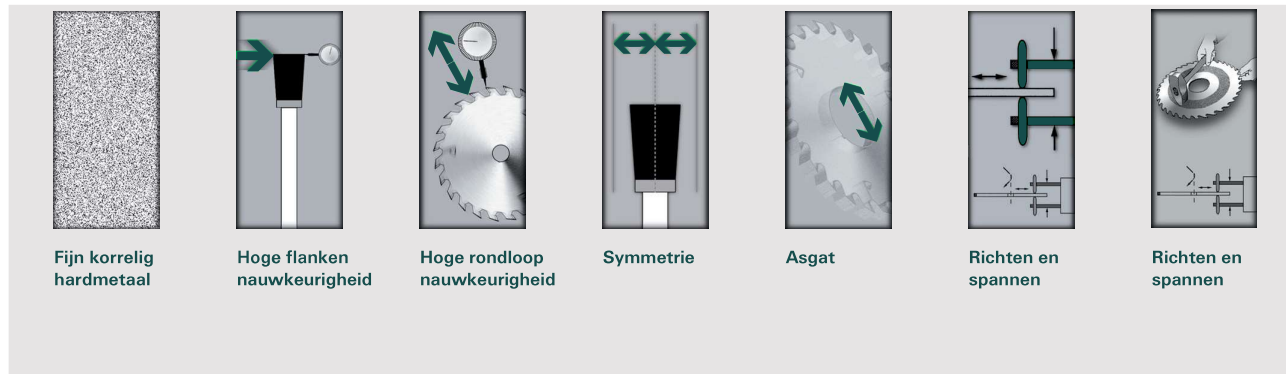

|   |   |   |
|---|---|---|
| <ul style="list-style-type: none"> <li>• <b>Kwaliteitsniveau 1-0-1</b></li> </ul> | <p>De standaardkwaliteit speciaal voor handcirkelzagen</p>  | <ul style="list-style-type: none"> <li>▶ Stamblad lasergesneden</li> <li>▶ Optimaal snijmateriaal voor de betreffende toepassing</li> <li>▶ Nauwkeurige fabricagetoleranties</li> <li>▶ Vanwege grotere tanden meermaals na te slijpen</li> <li>▶ Machinaal gecontroleerd richten en spannen</li> </ul>   |
| <ul style="list-style-type: none"> <li>• <b>Kwaliteitsniveau 2-0-6</b></li> </ul> | <p>De standaardkwaliteit voor tafel-, afkort- en verstekmachines met een uitstekende prijs-prestatieverhouding.</p> | <ul style="list-style-type: none"> <li>▶ Stamblad lasergesneden</li> <li>▶ Toepassingspecifiek gebruikt hardmetaal</li> <li>▶ Nauwe fabricagetoleranties</li> <li>▶ Hoge vlak- en rondloopnauwkeurigheid</li> <li>▶ Toepassinggerelateerde stillere uitvoering</li> <li>▶ Machinaal gecontroleerd richten en spannen</li> </ul>                           |
| <ul style="list-style-type: none"> <li>• <b>Kwaliteitsniveau 3-0-1</b></li> </ul> | <p>Het hoogste kwaliteitsniveau speciaal voor industriële toepassingen op stationaire machines.</p>                 | <ul style="list-style-type: none"> <li>▶ Stamblad lasergesneden</li> <li>▶ Toepassingspecifiek gebruikt zeer fijnkorrelig hardmetaal</li> <li>▶ Buitengewoon nauwe fabricagetoleranties</li> <li>▶ Hoogste vlak- en rondloopnauwkeurigheid</li> <li>▶ Stillere uitvoering</li> <li>▶ Handmatig en machinaal gecontroleerd richten en opspannen</li> </ul> |

— MATERIAALGESCHIKTHEID ZAGEN

## MATERIAAL

### ABRASIEF

ABRASIEF

Minerale materialen op basis van hout (bijv. gipsvezel- cementvezelplaten)



Harde en abrasieve kunststoffen en composietmaterialen

### BOUW

CONSTRUCTION

Soorten bouwplaatshout



Bekistingsplaten

Hout met spijkers

Met cement vervuld hout en platen

### HOUT

WOOD

Schulpen, in hard- en zacht hout, nat en droog

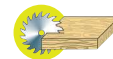

Afkorten in langvezelige houtsoorten



Afkorten in massief hout en materialen op basis van hout

### PLAAT

PANELS

Ruwe spaanplaat

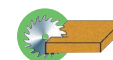

Platen van massief hout, meubelplaat en multiplex

Gefineerde en met papier beklede platen



Melamine- en foliebeklede platen

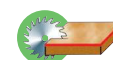

HPL/CPL-beklede platen

Abrasieve composietplaten



Kantfinez op massief hout, fineer- en kunststofranden

### ALUMINIUM

ALU

Profielen, dunne staalplaat en non-ferro-composietmaterialen



Aluminium en non-ferrometalen

### STAAL

STEEL

Formatteren van dunne staalplaat, profielen, non-ferro-metalen en gietijzer



Dunne rvs-plaat, composietmateriaal met rvs-bekleding/staalversterking

### KUNSTSTOF

KUNSTSTOF

Formateer- en versteksnedes in profielen van duroplast, thermoplast (bijv. acryl, PMMA, PE, PP, ...)



Formaatsnedes in platen van harde en abrasieve kunststoffen en composietmaterialen (bijv. Corian, Trespa, CFK, GFK, AFK, ...)



LEGENDE: SQ ▲ geschikt – SQ ▲▲▲ bijzonder geschikt | SW ▲ korte standtijd – SW ▲▲▲ lange standtijd | RS ritszaag



## TANDVORMEN

F



F

F-FA



F-FA

F-FA



F-FA

F



F

WS



WS

WSA



WSA



HR

HR

Hoofdzagen: **WS** [SQ ▲▲ | SW ▲▲ met RS], **WSA** [SQ ▲▲▲▲ | SW ▲▲▲ ]  
**F-WS-WS** [SQ ▲▲▲ | SW ▲▲ met / zonder RS]  
**TR-F-F DU** [SQ ▲▲▲ | SW ▲▲ met / zonder RS]  
**HR** [SQ ▲▲▲▲ | SW ▲▲▲▲ met / zonder RS]  
 Ritszagen: **WS** [SQ ▲▲ | SW ▲▲ ]  
 Groefzagen: **F** [SQ ▲▲ | SW ▲▲▲ ]

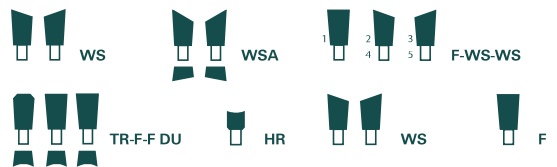

Hoofdzagen: **TR-F** [SQ ▲▲ | SW ▲▲ met RS]  
**DA-F DU** [SQ ▲▲▲ | SW ▲▲ met / zonder RS]  
**HR** [SQ ▲▲▲▲ | SW ▲▲▲▲ met / zonder RS]  
 Ritszagen: **F** [SQ ▲▲ | SW ▲▲ ], **KO-F** [SQ ▲▲ | SW ▲▲▲ ]  
 Groefzagen: **F** [SQ ▲▲ | SW ▲▲ ]  
**F-WS-WS** [SQ ▲▲▲ | SW ▲▲ ]

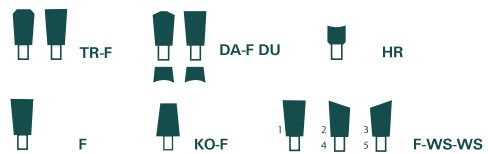

Hoofdzagen: **TR-F** [SQ ▲▲ | SW ▲▲ met RS]  
**DA-F-FA DU** [SQ ▲▲▲ | SW ▲▲▲ met / zonder RS]  
**HR** [SQ ▲▲▲▲ | SW ▲▲▲▲ met / zonder RS]  
 Ritszagen: **F** [SQ ▲▲ | SW ▲▲ ], **KO-F** [SQ ▲▲▲ | SW ▲▲ ]  
 Groefzagen: **F** [SQ ▲▲ | SW ▲▲ ]

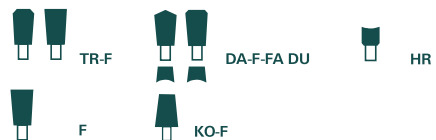

Afkortzagen: **WS** [SQ ▲▲ | SW ▲▲ ], **ES** [SQ ▲▲▲ | SW ▲▲ ]  
**DA-F** [SQ ▲▲ | SW ▲▲▲ ]



TR-F



TR-F

G7

TR-F



TR-F

F-WFA



F-WFA

WS-FA



WS-FA

TR-F-FA



TR-F-FA

## 9 FREZEN MET ASGAT

- Bij freesgereedschappen moet onderscheid gemaakt worden tussen een handmatige aanvoer en een mechanische aanvoer. Hiervoor moeten de voorschriften van de Berufsgenossenschaft BGHM worden aangehouden. In de kop van de tabel staat of gereedschappen voor handmatige (MAN) aanvoer zijn ontworpen.
- Voor een handmatige aanvoer (MAN) ontworpen gereedschappen zijn gewoonlijk gereedschappen met omkeermessen, hiervoor is een  $V_c$  van max. 80 m/s toegestaan.
- **Snijmateriaal:**  
In messenkoppen kunnen verschillende omkeermessen en messen gemonteerd worden zodat ze voor verschillende toepassingen geoptimaliseerd kunnen worden. De informatie in de catalogus geldt voor de messen die in het nieuwe gereedschap zijn gemonteerd en waarmee deze gereedschappen worden afgeleverd.

## 10 CNC/ BOVENFREZEN

### — Basisinvloeden voor de $f_z$

- Stabiliteit (hoe stabielier des te  $> f_z$ )

- ▶ Hoe  $>$  de schachtdiameter, des te  $> f_z$   
( $f_z$ -gegevens gelden voor  $d=20$  mm)
- ▶ Hoe  $>$  de dichtheid van de kop, des te  $> f_z$   
( $f_z$ -gegevens gelden voor stalen koppen; bij koppen van zwaar metaal en volhardmetaal volgt er een  $> f_z$ )
- ▶ Hoe zwaarder de machinetafel, des te  $> f_z$

- ▶ Machineconstructie:  
Portaal is stabielier dan dwarsarmmachine
- ▶ Aantal assen: Een 3-assige machine is stabielier dan een vergelijkbare 5-assige machine
- ▶ Gereedschap-gereedschaphouder: HSK is stabielier dan SK of BT
- ▶ Werkstukopspanning hoe meer zuigkracht/opspankracht vlakbij de freeskant, des te stabielier de werkstukopspanning

- Materiaaldikte:

Hoe  $>$  het materiaal, des te  $>$  het verspaanvolume, des te  $< f_z$   
( $f_z$ -gegevens gelden voor een materiaaldikte van ong. 25 mm)

- Soort bewerking:

Hoe  $>$  het verspaanvolume, des te  $< f_z$   
( $f_z$ -gegevens gelden voor groeffrezen; bij doorsnijden  $< f_z$ ; bij voegfrezen  $> f_z$ )

- Bij schachtfrezen kan de aanbevolen snijsnelheid door de kleine gereedschapdiameter en de toerentalbeperking gewoonlijk niet bereikt worden. Daarom wordt gewoonlijk het capaciteitsbereik van de CNC-machine benut, gewoonlijk 18.000 of 24.000 omw/min.

## 11 BOREN

- Het toerenbereik bij boren is afhankelijk van de gereedschapdiameter en ligt tussen de 2500 en 9000 omw/min. Daarvan afgeleid wordt de aanvoer gedefinieerd.
- Aanvoer  $V_f$  bij ruwe spaanplaat:

- Spiraalboor: 0,6 – 5,0 m/min
- Doorgangsboor HW: 0,6 – 3,1 m/min
- Doorgangsboor, met VHW-schacht: 1,0 – 3,8 m/min
- Doorgangsboor DP: 0,6 – 2,5 m/min

- Deuvelboor: 1,25 – 5,0 m/min
- Deuvelboor met VHW-schacht: 1,25 – 7,5 m/min
- Beslagboor HW: 1,2 – 3,8 m/min
- Beslagboor DP: 0,6 – 3,1 m/min

— Aanvoer  $V_f$  bij met melamine beklede spaanplaat

|                                   |                 |                               |                 |
|-----------------------------------|-----------------|-------------------------------|-----------------|
| • Spiraalboor:                    | 0,5 – 4,0 m/min | • Deuvelboor:                 | 1,0 – 4,0 m/min |
| • Doorgangsboor HW:               | 0,5 – 2,5 m/min | • Deuvelboor met VHW-schacht: | 1,0 – 6,0 m/min |
| • Doorgangsboor, met VHW-schacht: | 0,8 – 3,0 m/min | • Beslagboor HW:              | 1,0 – 3,0 m/min |
| • Doorgangsboor DP:               | 0,5 – 2,0 m/min | • Beslagboor DP:              | 0,5 – 2,5 m/min |

— Aanvoer  $V_f$  bij gefineerde en met papier beklede spaanplaat, MDF en massief hout

|                                   |                 |                               |                 |
|-----------------------------------|-----------------|-------------------------------|-----------------|
| • Spiraalboor:                    | 0,4 – 3,0 m/min | • Deuvelboor:                 | 0,8 – 3,2 m/min |
| • Doorgangsboor HW:               | 0,4 – 1,9 m/min | • Deuvelboor met VHW-schacht: | 0,8 – 4,5 m/min |
| • Doorgangsboor, met VHW-schacht: | 0,6 – 2,3 m/min | • Beslagboor HW:              | 0,8 – 2,3 m/min |
| • Doorgangsboor DP:               | 0,4 – 1,5 m/min | • Beslagboor DP:              | 0,4 – 1,9 m/min |

Aansluitingen voor booropnamen

Schroefdraad uitvoering voor hieronder genoemde machinetoepassingen

| Type | Maschinenzuordnung   |
|------|--|
| A    | Nottmeyer, Lehbrink, Pankoke + Kochsiek, Prieß + Horstmann   |
| B    | Ayen, Holzma, Knoevenagel, Mayer, Brandt, Reichenbacher, Torwegge, Zubiola   |
| C    | Nottmeyer  |
| D    | Böttchner + Gessner, Biesse, Busellato, Dingenotto, Hüllhorst, Holz-Her, Homag, Koch, Morbidelli, Reimall, Torwegge, Weeke, Reich          |
| E    | Bilek Type KÜN, Knoevenagel  |
| F    | Alberti, Balestrini, Bilek (05 R), Busellato, Dubus, Goma, Grotefeld, Omeg, Reimall, Schleicher, SCM, Tanzani, Viciani, Vitap, Weingärtner |
| G    | Scheer   |

## 12 MESSEN / HW / DP / DM KWALITEITEN:

- Een kleine snijhoek en een grote spaanhoek betekenen scherpe snijkanten maar ook een snelle slijtage.
- Hoe harder het snijmateriaal, des te groter moet de snijhoek zijn (om snijkantbreuk te voorkomen). Daaruit volgt een stompe spaanhoek. Daarmee wordt de standtijd langer, ten koste van de scherppte.
- Materialen die scherpe snijkanten vereisen (zoals massief hout, multiplex, ...), kunnen alleen met DP-gereedschap bewerkt worden als deze een zeer grote ashoek hebben.
- **SNIJMATERIAAL:**  
De volgende snijmaterialen worden gebruikt voor omkeermessen en wisselmessen van Stehle:

- Snijmaterialen voor materialen op basis van hout en universele toepassing:
  - ▶ TC02
  - ▶ TC03
  - ▶ TC05
  - ▶ TC06

- Snijmateriaal voor massief hout:
  - ▶ TCw15
  - ▶ TCw25
  - ▶ TCw30
  - ▶ TCw40

# Verkooprichtlijnen

## — NABEWERKEN EN AANPASSEN

- Nabewerkingen en aanpassingen bij nieuwe gereedschappen worden uitsluitend uitgevoerd onder volledige aanhouding van de wettelijke en veiligheidstechnische voorschriften.
- De levering van uit voorraad leverbare gereedschappen kan daardoor enkele dagen vertraging oplopen. Overleg dit vooraf met de binnendienst van Stehle.
- Speciale ombewerkingen van het asgat van standaard gereedschappen worden volgens de geldende modificatieprijslijst aangeboden en berekend. Bij DP gereedschappen wordt op standaard geen ombewerking uitgevoerd.

## — BESTELINFORMATIE

- Deze catalogus en de bijbehorende prijslijst vervangen alle eerdere catalogusedities en genoemde prijzen.
- De informatie over levertijden conform de aangegeven voorraadcode is indicatief en kan gedurende de geldigheidsduur van de catalogus veranderen. Actuele details krijgt u via de binnendienst van Stehle.

## — HOEVEELHEDEN

- De basis verkoop- en verpakkingseenheid is in stuks.
- Bij kleine onderdelen (omkeermessen, messen, schroeven etc.) kan een verpakkingseenheid ook uit meerdere stuks bestaan. In dergelijke gevallen kan alleen geleverd worden in aantallen conform de verpakkingseenheden.
- Als er sets worden aangeboden die bestaan uit diverse gereedschappen kunnen deze alleen als complete set worden besteld.
- Bij grotere hoeveelheden is korting mogelijk. Vraag deze aan bij de binnendienst van Stehle.

## — LEVERINGSVOORWAARDEN

- Gereedschapleveranties in Nederland worden franco op de plaats van bestemming geleverd vanaf een orderwaarde van € 100,00 netto
- Voor exportleveranties gelden gewoonlijk de voorwaarden af fabriek.
- De meerkosten voor spoedverzending, bijv. expres, luchtvracht etc. worden tegen de gemaakte kosten in rekening gebracht.

## — ORDERAFWIKKELING

- Houd bij vragen het nummer van onze orderbevestiging, ons kenmerk, onze datum en uw bestelgegevens bij de hand. Dit versnelt de bewerking.
- Voor stornering is onze schriftelijke instemming en bevestiging nodig. Tot dan toe gemaakte kosten (bijv. voor speciale producten en wijzigingen) zijn voor rekening van de opdrachtgever.
- **Retourzending van goederen:**  
Op voorraad zijnde goederen kunnen alleen na afspraak met de verantwoordelijke Stehle-medewerker binnen de garantietermijn in de originele toestand worden teruggenomen. Hiervoor wordt een bewerkingstoeslag in rekening gebracht. Voor beschadigde verpakkingen moet een vergoeding gegeven worden. Speciale producten en aangepaste gereedschappen worden niet teruggenomen.

## — ALGEMENE VOORWAARDEN:

- Lees de volledige actuele algemene leveringsvoorwaarden van Stehle op de website: [www.stehle.nl](http://www.stehle.nl)

# Diameter-index cirkelzaagbladen

| Ø D [mm] | Ø d [mm] | Z     | Tand-vorm | Bestel-nummer | Programma                                     | Pagina | Ø D [mm] | Ø d [mm] | Z    | Tand-vorm | Bestel-nummer | Programma                                    | Pagina     |
|----------|----------|-------|-----------|---------------|---|--------|----------|----------|------|-----------|---------------|--|------------|
| 70       | 20       | 2x8   | F         | 50445100      | HW RS2  | 1-29   | 150      | 20       | 24   | WS        | 50110039      | HW HKS - Massief                             | 1-5        |
| 80       | 20       | 2x10  | F         | 58802435      | HW RS2  | 1-29   | 150      | 20       | 30   | TR-F      | 58116502      | HW Unisteel (HKS)                            | 1-11       |
| 90       | 30       | 20    | WS        | 58808800      | HW KKO  | 1-58   | 150      | 20       | 36   | WS        | 50110040      | HW HKS - Board                               | 1-6        |
| 100      | 12       | 30    | WS        | 50110001      | HW HKS - Board                                | 1-6    | 150      | 20       | 42   | TR-F      | 58115002      | HW Parat - negatief                          | 1-12       |
| 100      | 20       | 20    | KO-F      | 58807950      | HW RSK - nn-System                            | 1-27   | 150      | 20       | 48   | WS        | 50110041      | HW HKS - Board                               | 1-6        |
| 100      | 20       | 2x10  | F         | 58110190      | HW RS2  | 1-29   | 150      | 22       | 48   | WS        | 58808811      | HW KKO                                       | 1-58       |
| 100      | 22       | 12    | WS        | 58808801      | HW KKO  | 1-58   | 150      | 30       | 24   | WS        | 50110042      | HW HKS - Massief                             | 1-5        |
| 100      | 22       | 20    | WS        | 58808802      | HW KKO  | 1-58   | 150      | 30       | 24   | WS        | 58100096      | HW ZQW                                       | 1-20       |
| 100      | 22       | 20    | WS        | 58808836      | HW KKO  | 1-58   | 150      | 30       | 36   | WS        | 58100099      | HW ZWS                                       | 1-21       |
| 100      | 22       | 2x10  | F         | 58110188      | HW RS2  | 1-29   | 150      | 30       | 44   | ES        | 58808833      | HW KKE                                       | 1-60       |
| 100      | 22       | 30    | WS        | 50110003      | HW HKS - Board                                | 1-6    | 150      | 30       | 44   | ES        | 58808834      | HW KKE                                       | 1-60       |
| 100      | 30       | 12    | F         | 50750144      | DP RNK  | 2-7    | 150      | 30       | 48   | WS        | 58100101      | HW ZWS                                       | 1-21       |
| 100      | 30       | 35    | F-WS-WS   | 50806250      | HW RNK-Matador 5                              | 2-6    | 150      | 30       | 48   | WS        | 58808823      | HW KKM                                       | 1-59       |
| 100      | 30       | 35    | F-WS-WS   | 50806252      | HW RNK-Matador 5                              | 2-6    | 150      | 40       | 30   | WS        | 58808840      | HW KKM                                       | 1-59       |
| 100      | 32       | 30    | WS        | 58808804      | HW KKO  | 1-58   | 152      | 20       | 24   | WS        | 58114125      | HW HKS - Massief                             | 1-5        |
| 100      | 32       | 30    | ES        | 58808829      | HW KKE  | 1-60   | 160      | 16       | 24   | WS        | 50110051      | HW HKS - Massief                             | 1-5        |
| 100      | 32       | 30    | ES        | 58808830      | HW KKE  | 1-60   | 160      | 16       | 48   | WS        | 50110053      | HW HKS - Board                               | 1-6        |
| 100      | 32       | 30    | ES        | 58808831      | HW KKE  | 1-60   | 160      | 20       | 4    | F         | 50457997      | DP HKS - LR                                  | 1-7        |
| 100      | 32       | 30    | ES        | 58808832      | HW KKE  | 1-60   | 160      | 20       | 4    | F-FA      | 58458790      | DP HKS - L2                                  | 1-9        |
| 100      | 32       | 30    | ES        | 58808841      | HW KKE  | 1-60   | 160      | 20       | 6    | F         | 50460479      | DP   | 1-2        |
| 100      | 32       | 30    | ES        | 58808842      | HW KKE  | 1-60   | 160      | 20       | 8    | F         | 50457379      | DP HKS - L                                   | 1-8        |
| 105      | 20       | 2x10  | F         | 58110171      | HW RS2  | 1-29   | 160      | 20       | 12   | WS        | 50110244      | HW HKS - Massief                             | 1-5        |
| 105      | 22       | 30    | WS        | 50110006      | HW HKS - Board                                | 1-6    | 160      | 20       | 18   | F-WS      | 58110413      | HW HKS - Massief - Accuhandcirkelzagen       | 1-1        |
| 110      | 22       | 20    | WS        | 58808805      | HW KKO  | 1-58   | 160      | 20       | 20   | HR        | 58459771      | DP HKS - nn-System DP flex                   | 1-10       |
| 110      | 32       | 20    | WS        | 58808806      | HW KKO  | 1-58   | 160      | 20       | 24   | WS        | 50110054      | HW HKS - Massief                             | 1-13, 1-5  |
| 110      | 40       | 20    | WS        | 58808837      | HW KKM  | 1-59   | 160      | 20       | 2x16 | ES        | 58807910      | HW Ritscirkelzaagblad HW - verstellbaar 'ES' | 1-30       |
| 110      | 40       | 20    | WS        | 58808838      | HW KKM  | 1-59   | 160      | 20       | 30   | F         | 50458171      | DP HKS - L                                   | 1-8        |
| 120      | 20       | 24    | WS        | 50104061      | HW HKS - Massief                              | 1-5    | 160      | 20       | 30   | TR-F      | 58116504      | HW Unisteel (HKS)                            | 1-11       |
| 120      | 20       | 24    | WS        | 58459419      | DP RSK - nn-System                            | 1-35   | 160      | 20       | 30   | HR        | 58459767      | DP HKS - nn-System DP flex                   | 1-10       |
| 120      | 20       | 24    | KO-F      | 58807951      | HW RSK - nn-System                            | 1-27   | 160      | 20       | 36   | WS        | 50110055      | HW HKS - Board                               | 1-13, 1-6  |
| 120      | 20       | 2x12  | F         | 58110186      | HW RS2  | 1-29   | 160      | 20       | 40   | TR-F      | 58116402      | HW HKS - Massief                             | 1-4        |
| 120      | 20       | 6     | F         | 50457378      | DP HKS - L                                    | 1-8    | 160      | 20       | 40   | TR-F      | 58458784      | HT HKS - Mega-Steel                          | 1-3        |
| 120      | 20       | 40    | TR-F      | 58104063      | HW TRF  | 1-24   | 160      | 20       | 42   | TR-F      | 58115004      | HW Parat - negatief                          | 1-12, 1-13 |
| 120      | 22       | 16    | KO-F      | 58750101      | DP RSK  | 1-28   | 160      | 20       | 48   | WS        | 50110056      | HW HKS - Board                               | 1-13, 1-6  |
| 120      | 22       | 24    | WS        | 58459365      | DP RSK - nn-System                            | 1-35   | 160      | 20       | 48   | TR-F      | 58110161      | HW TRF                                       | 1-24       |
| 120      | 22       | 24    | KO-F      | 58807952      | HW RSK - nn-System                            | 1-27   | 160      | 20       | 48   | F-WS      | 58110419      | HW HKS - Massief                             | 1-1        |
| 120      | 22       | 2x12  | WS        | 50750102      | DP RSVS                                       | 1-31   | 160      | 20       | 48   | WS-FA     | 58116000      | HW KKS - Plastic                             | 1-55       |
| 120      | 22       | 2x12  | WS        | 50807854      | HW RSVS                                       | 1-30   | 160      | 20       | 48   | WS        | 58808812      | HW KKO                                       | 1-58       |
| 120      | 22       | 2x12  | F         | 58110187      | HW RS2  | 1-29   | 160      | 20       | 48   | WS        | 58110356      | HW HKS - Board                               | 1-6        |
| 120      | 32       | 20    | WS        | 58808808      | HW KKO  | 1-58   | 160      | 20       | 56   | TR-F      | 58110142      | HW TRF                                       | 1-24       |
| 120      | 40       | 24    | WS        | 58808819      | HW KKM  | 1-59   | 160      | 20       | 56   | TR-F      | 58115042      | HW Parat - negatief                          | 1-12       |
| 120      | 40       | 36    | WS        | 58808839      | HW KKM  | 1-59   | 160      | 22       | 36   | WS        | 58808813      | HW KKO                                       | 1-58       |
| 120      | 50       | 12+12 | ES        | 58459461      | DP RSK - nn-systeem DP flex 'WS'-verstellbaar | 1-36   | 160      | 22       | 36   | WS        | 58808843      | HW KKO                                       | 1-58       |
| 120      | 50       | 2x12  | WS        | 50750105      | DP RSVS                                       | 1-31   | 160      | 22       | 48   | WS        | 58808814      | HW KKO                                       | 1-58       |
| 120      | 50       | 2x12  | WS        | 50807902      | HW RSVS                                       | 1-30   | 160      | 30       | 8    | F         | 50457377      | DP HKS - L                                   | 1-8        |
| 125      | 20       | 20    | WS        | 50110011      | HW HKS - Massief                              | 1-5    | 160      | 30       | 8    | F         | 50750148      | DP RNK                                       | 2-7        |
| 125      | 20       | 24    | WS        | 58459436      | DP RSK - nn-System                            | 1-35   | 160      | 30       | 8    | F         | 50750149      | DP RNK                                       | 2-7        |
| 125      | 20       | 24    | KO-F      | 58807953      | HW RSK - nn-System                            | 1-27   | 160      | 30       | 24   | WS        | 50110057      | HW HKS - Massief                             | 1-5        |
| 125      | 20       | 2x12  | F         | 58110206      | HW RS2  | 1-29   | 160      | 30       | 24   | WS        | 58808815      | HW KKO                                       | 1-58       |
| 125      | 20       | 36    | WS        | 50110012      | HW HKS - Board                                | 1-6    | 160      | 30       | 36   | WS        | 50110058      | HW HKS - Board                               | 1-6        |
| 125      | 22       | 24    | WS        | 50806200      | HW RSK  | 1-26   | 160      | 30       | 42   | TR-F      | 58115026      | HW Parat - negatief                          | 1-12       |
| 125      | 22       | 2x12  | F         | 58110204      | HW RS2  | 1-29   | 160      | 30       | 48   | WS        | 50110059      | HW HKS - Board                               | 1-6        |
| 125      | 30       | 12    | F         | 50750145      | DP RNK  | 2-7    | 160      | 40       | 30   | WS        | 58808816      | HW KKO                                       | 1-58       |
| 125      | 30       | 35    | F-WS-WS   | 50806251      | HW RNK-Matador 5                              | 2-6    | 160      | 45       | 30   | KO-F      | 50750121      | DP RSK                                       | 1-44       |
| 125      | 30       | 35    | F-WS-WS   | 50806253      | HW RNK-Matador 5                              | 2-6    | 160      | 55       | 36   | KO-F      | 58803072      | HW RSK - nn-System                           | 1-43       |
| 125      | 30       | 36    | WS        | 58808820      | HW KKM  | 1-59   | 165      | 15,88    | 24   | F-WS      | 58110421      | HW HKS - Massief                             | 1-1        |
| 125      | 32       | 24    | WS        | 58808835      | HW KKO  | 1-58   | 165      | 15,88    | 40   | F-WS      | 58110405      | HW HKS - Massief - Accuhandcirkelzagen       | 1-1        |
| 130      | 20       | 20    | WS        | 50110017      | HW HKS - Massief                              | 1-5    | 165      | 20       | 6    | F         | 50460480      | DP   | 1-2        |
| 130      | 20       | 36    | WS        | 50110018      | HW HKS - Board                                | 1-6    | 165      | 20       | 18   | F-WS      | 58110402      | HW HKS - Massief - Accuhandcirkelzagen       | 1-1        |
| 130      | 20       | 36    | TR-F      | 58115027      | HW Parat - negatief                           | 1-12   | 165      | 20       | 24   | WS        | 50110060      | HW HKS - Massief                             | 1-5        |
| 136      | 20       | 4     | F         | 50460500      | DP  | 1-2    | 165      | 20       | 24   | F-WS      | 58110403      | HW HKS - Massief - Accuhandcirkelzagen       | 1-1        |
| 136      | 20       | 18    | F-WS      | 58110400      | HW HKS - Massief - Accuhandcirkelzagen        | 1-1    | 165      | 20       | 24   | F-WS      | 58110423      | HW HKS - Massief                             | 1-1        |
| 136      | 20       | 24    | F-WS      | 58110401      | HW HKS - Massief - Accuhandcirkelzagen        | 1-1    | 165      | 20       | 36   | WS        | 50110061      | HW HKS - Board                               | 1-6        |
| 136      | 20       | 36    | TR-F      | 58116400      | HW HKS - Unisteel - Accuhandcirkelzagen       | 1-4    | 165      | 20       | 36   | F-WS      | 58110404      | HW HKS - Massief - Accuhandcirkelzagen       | 1-1        |
| 140      | 16       | 36    | WS        | 58808809      | HW KKO  | 1-58   | 165      | 20       | 40   | TR-F      | 58116401      | HW HKS - Massief                             | 1-4        |
| 140      | 20       | 12    | WS        | 50110242      | HW HKS - Massief                              | 1-5    | 165      | 20       | 48   | WS        | 50110062      | HW HKS - Board                               | 1-6        |
| 140      | 20       | 20    | WS        | 50110028      | HW HKS - Massief                              | 1-5    | 165      | 20       | 48   | F-WS      | 58110420      | HW HKS - Massief                             | 1-1        |
| 140      | 20       | 36    | WS        | 50110029      | HW HKS - Board                                | 1-6    | 165      | 20       | 48   | TR-F      | 58115044      | HW Parat - negatief                          | 1-12       |
| 140      | 22       | 36    | WS        | 58808810      | HW KKO  | 1-58   | 165      | 30       | 24   | WS        | 50110130      | HW HKS - Massief                             | 1-5        |
| 140      | 30       | 36    | WS        | 58808821      | HW KKM  | 1-59   | 170      | 30       | 24   | WS        | 50110069      | HW HKS - Massief                             | 1-5        |
| 140      | 30       | 36    | WS        | 58808822      | HW KKM  | 1-59   | 170      | 30       | 36   | WS        | 50110070      | HW HKS - Board                               | 1-6        |
| 140      | 36       | 2x12  | WS        | 50807909      | HW RSVS                                       | 1-30   | 170      | 30       | 36   | WS        | 58808817      | HW KKO                                       | 1-58       |
| 150      | 20       | 12    | WS        | 50110243      | HW HKS - Massief                              | 1-5    | 170      | 30       | 48   | WS        | 50110071      | HW HKS - Board                               | 1-6        |

# Diameter-index cirkelzaagbladen

| Ø D [mm] | Ø d [mm] | Z  | Tand-vorm | Bestel-nummer | Programma                              | Pagina     | Ø D [mm] | Ø d [mm] | Z  | Tand-vorm | Bestel-nummer | Programma                              | Pagina     |
|----------|----------|----|-----------|---------------|--|------------|----------|----------|----|-----------|---------------|--|------------|
| 180      | 16       | 24 | WS        | 50110081      | HW HKS - Massief                       | 1-5        | 200      | 30       | 40 | TR-F      | 58116511      | HW Unisteel (HKS)                      | 1-11       |
| 180      | 16       | 48 | WS        | 50110183      | HW HKS - Board                         | 1-6        | 200      | 30       | 48 | WS        | 50110096      | HW HKS - Board                         | 1-7        |
| 180      | 20       | 14 | WS        | 50110247      | HW HKS - Massief                       | 1-5        | 200      | 30       | 48 | WS        | 58100091      | HW ZWS                                 | 1-21       |
| 180      | 20       | 24 | WS        | 50110075      | HW HKS - Massief                       | 1-5        | 200      | 30       | 54 | TR-F      | 58115011      | HW Parat - negatief                    | 1-12       |
| 180      | 20       | 36 | TR-F      | 58116507      | HW Unisteel (HKS)                      | 1-11       | 200      | 30       | 60 | WS        | 50110097      | HW HKS - Board                         | 1-7        |
| 180      | 20       | 40 | WS        | 50110076      | HW HKS - Board                         | 1-6        | 200      | 30       | 64 | WS        | 58100025      | HW ZWS                                 | 1-21       |
| 180      | 20       | 48 | TR-F      | 58115007      | HW Parat - negatief                    | 1-12       | 200      | 30       | 64 | WS        | 58808818      | HW KKO                                 | 1-58       |
| 180      | 20       | 54 | WS        | 50110077      | HW HKS - Board                         | 1-6        | 200      | 30       | 65 | F-WS-WS   | 58808702      | HW Matador 5                           | 1-23       |
| 180      | 22       | 36 | WS        | 58192964      | DP RSK - nn-System                     | 1-35       | 200      | 45       | 30 | KO-F      | 50750127      | DP RSK                                 | 1-44       |
| 180      | 22       | 36 | F         | 58806210      | HW RSK                                 | 1-26       | 200      | 45       | 36 | KO-F      | 58803074      | HW RSK - nn-System                     | 1-43       |
| 180      | 30       | 4  | F-FA      | 58458799      | DP HKS - L2                            | 1-9        | 200      | 45       | 36 | KO-F      | 58806134      | HW RSK - nn-System                     | 1-43       |
| 180      | 30       | 14 | WS        | 50110248      | HW HKS - Massief                       | 1-5        | 200      | 65       | 30 | KO-F      | 50750126      | DP RSK                                 | 1-44       |
| 180      | 30       | 24 | WS        | 50110078      | HW HKS - Massief                       | 1-5        | 200      | 65       | 36 | KO-F      | 58806130      | HW RSK - nn-System                     | 1-43       |
| 180      | 30       | 30 | KO-F      | 50750122      | DP RSK                                 | 1-44       | 203      | 30       | 24 | WS        | 58114132      | HW HKS - Massief                       | 1-5        |
| 180      | 30       | 30 | WS        | 58100016      | HW ZQW                                 | 1-20       | 205      | 18       | 30 | WS        | 50110286      | HW HKS - Massief                       | 1-5        |
| 180      | 30       | 30 | KO-F      | 58807858      | HW RSK - nn-System                     | 1-43       | 210      | 30       | 12 | F         | 50457358      | DP HKS - L                             | 1-8        |
| 180      | 30       | 30 | KO-WS     | 58807970      | RSK-WS                                 | 1-45       | 210      | 30       | 14 | F-FA      | 50112013      | HW BKS (NAIL)                          | 1-16       |
| 180      | 30       | 36 | TR-F      | 58116508      | HW Unisteel (HKS)                      | 1-11       | 210      | 30       | 18 | WS        | 50110253      | HW HKS - Massief                       | 1-5        |
| 180      | 30       | 40 | WS        | 50110079      | HW HKS - Board                         | 1-6        | 210      | 30       | 30 | WS        | 50110104      | HW HKS - Massief                       | 1-5        |
| 180      | 30       | 48 | TR-F      | 58115008      | HW Parat - negatief                    | 1-12       | 210      | 30       | 40 | TR-F      | 58116512      | HW Unisteel (HKS)                      | 1-11       |
| 180      | 30       | 54 | WS        | 50110080      | HW HKS - Board                         | 1-6        | 210      | 30       | 48 | WS        | 50110105      | HW HKS - Board                         | 1-7        |
| 180      | 30       | 54 | WS        | 58100015      | HW ZWS                                 | 1-21       | 210      | 30       | 48 | WS        | 58110194      | HW K + G negatief                      | 1-15       |
| 180      | 30       | 54 | WS        | 58808824      | HW KKM                                 | 1-59       | 210      | 30       | 48 | WS        | 58110194      | HW K + G negatief                      | 1-15       |
| 180      | 30       | 60 | F-WS-WS   | 58808701      | HW Matador 5                           | 1-23       | 210      | 30       | 54 | TR-F-FA   | 50808601      | HW KKS - Hard plastic                  | 1-57       |
| 180      | 45       | 30 | KO-F      | 50750123      | DP RSK                                 | 1-44       | 210      | 30       | 54 | TR-F      | 58115012      | HW Parat - negatief                    | 1-12       |
| 180      | 45       | 30 | KO-F      | 50750124      | DP RSK                                 | 1-44       | 210      | 30       | 54 | TR-TR     | 58808610      | HW KKS - hard plastic negatief         | 1-57       |
| 180      | 45       | 36 | KO-F      | 58803104      | HW RSK - nn-System                     | 1-43       | 210      | 30       | 60 | WS        | 50110106      | HW HKS - Board                         | 1-7        |
| 180      | 45       | 36 | KO-F      | 58807862      | HW RSK                                 | 1-43       | 210      | 30       | 60 | F-WS      | 58110408      | HW HKS - Massief - Accuhandcirkelzagen | 1-1        |
| 184      | 16       | 40 | WS        | 50110282      | HW HKS - Massief                       | 1-5        | 216      | 30       | 4  | F-FA      | 58458792      | DP HKS - L2                            | 1-9        |
| 184      | 16       | 56 | F-WS      | 58110406      | HW HKS - Massief - Accuhandcirkelzagen | 1-1        | 216      | 30       | 12 | F         | 50458137      | DP HKS - L                             | 1-8        |
| 184      | 20       | 24 | WS        | 50110082      | HW HKS - Massief                       | 1-5        | 216      | 30       | 24 | WS        | 58110180      | HW K + G negatief                      | 1-14, 1-15 |
| 184      | 20       | 24 | F-WS      | 58110416      | HW HKS - Massief                       | 1-1        | 216      | 30       | 24 | F-WS      | 58110409      | HW HKS - Massief - Accuhandcirkelzagen | 1-1        |
| 190      | 16       | 24 | WS        | 50110153      | HW HKS - Massief                       | 1-5        | 216      | 30       | 30 | WS        | 50110107      | HW HKS - Massief                       | 1-5        |
| 190      | 16       | 30 | WS        | 50110083      | HW HKS - Board                         | 1-6        | 216      | 30       | 36 | F-WS      | 58110410      | HW HKS - Massief - Accuhandcirkelzagen | 1-1        |
| 190      | 16       | 42 | WS        | 50110084      | HW HKS - Board                         | 1-6        | 216      | 30       | 40 | TR-F      | 58116520      | HW Unisteel (HKS)                      | 1-11       |
| 190      | 20       | 4  | F-FA      | 58458800      | DP HKS - L2                            | 1-9        | 216      | 30       | 40 | HR        | 58459769      | DP HKS - nn-System DP flex             | 1-10       |
| 190      | 20       | 16 | WS        | 50110250      | HW HKS - Massief                       | 1-5        | 216      | 30       | 48 | WS        | 50110108      | HW HKS - Board                         | 1-7        |
| 190      | 20       | 24 | WS        | 50110154      | HW HKS - Massief                       | 1-5        | 216      | 30       | 48 | WS        | 58110181      | HW K + G negatief                      | 1-14, 1-15 |
| 190      | 20       | 30 | WS        | 50110086      | HW HKS - Board                         | 1-6        | 216      | 30       | 56 | TR-F      | 58458786      | HT HKS - Mega-Steel                    | 1-3        |
| 190      | 20       | 38 | TR-F      | 58116509      | HW Unisteel (HKS)                      | 1-11       | 216      | 30       | 60 | WS        | 50110109      | HW HKS - Board                         | 1-7        |
| 190      | 20       | 48 | WS        | 50110087      | HW HKS - Board                         | 1-6        | 216      | 30       | 60 | WS        | 58110192      | HW K + G negatief                      | 1-15       |
| 190      | 20       | 48 | F-WS      | 58110407      | HW HKS - Massief - Accuhandcirkelzagen | 1-1        | 216      | 30       | 60 | F-WS      | 58110411      | HW HKS - Massief - Accuhandcirkelzagen | 1-1        |
| 190      | 20       | 54 | TR-F      | 58115009      | HW Parat - negatief                    | 1-12       | 216      | 30       | 60 | TR-F      | 58115024      | HW Parat - negatief                    | 1-12, 1-14 |
| 190      | 20FX     | 32 | WS        | 50110266      | HW HKS - Board                         | 1-6        | 216      | 30       | 60 | WS-FA     | 58116002      | HW KKS - Plastic                       | 1-55       |
| 190      | 20FX     | 48 | WS        | 50110267      | HW HKS - Board                         | 1-6        | 216      | 30       | 60 | TR-F      | 58458780      | HW TRF                                 | 1-24       |
| 190      | 20FX     | 54 | TR-F      | 58110229      | HW TRF                                 | 1-24       | 216      | 30       | 60 | TR-TR     | 58808611      | HW KKS - hard plastic negatief         | 1-57       |
| 190      | 20FX     | 58 | TR-F      | 58115033      | HW Parat - negatief                    | 1-12       | 216      | 30       | 80 | TR-F      | 58115034      | HW Parat - negatief                    | 1-12       |
| 190      | 20FX     | 60 | WS        | 50110268      | HW HKS - Board                         | 1-6        | 220      | 30       | 24 | WS        | 50110164      | HW HKS - Massief                       | 1-5        |
| 190      | 30       | 4  | F         | 50457994      | DP HKS - LR                            | 1-7        | 220      | 30       | 36 | WS        | 50110110      | HW HKS - Massief                       | 1-5        |
| 190      | 30       | 4  | F-FA      | 58458791      | DP HKS - L2                            | 1-9        | 220      | 30       | 42 | DA-F DU   | 58804281      | HW KDF - Industry                      | 1-32       |
| 190      | 30       | 8  | F         | 50457357      | DP HKS - L                             | 1-8        | 220      | 30       | 48 | WS        | 50110111      | HW HKS - Board                         | 1-7        |
| 190      | 30       | 14 | F-FA      | 58112011      | HW BKS (NAIL)                          | 1-16       | 220      | 30       | 54 | TR-F      | 58115021      | HW Parat - negatief                    | 1-12       |
| 190      | 30       | 16 | WS        | 50110251      | HW HKS - Massief                       | 1-5        | 220      | 30       | 64 | WS        | 50110112      | HW HKS - Board                         | 1-7        |
| 190      | 30       | 20 | WS        | 58110415      | HW HKS - Massief                       | 1-2        | 220      | 30       | 64 | TR-F      | 58100399      | HW TRF                                 | 1-24       |
| 190      | 30       | 24 | WS        | 50110155      | HW HKS - Massief                       | 1-13, 1-5  | 220      | 30       | 70 | F-WS-WS   | 58808712      | HW Matador 5                           | 1-23       |
| 190      | 30       | 24 | F-WS      | 58110417      | HW HKS - Massief - Accuhandcirkelzagen | 1-1        | 220      | 40       | 70 | F-WS-WS   | 58808703      | HW Matador 5                           | 1-23       |
| 190      | 30       | 24 | WS        | 58114105      | HW HKS - Massief                       | 1-5        | 225      | 30       | 24 | WS        | 50110165      | HW HKS - Massief                       | 1-5        |
| 190      | 30       | 30 | WS        | 50110089      | HW HKS - Board                         | 1-13, 1-7  | 225      | 30       | 34 | WS        | 50110228      | HW HKS - Massief                       | 1-6        |
| 190      | 30       | 30 | F         | 58457361      | DP HKS - L                             | 1-8        | 225      | 30       | 48 | WS        | 50110237      | HW HKS - Board                         | 1-7        |
| 190      | 30       | 36 | HR        | 58459768      | DP HKS - nn-System DP flex             | 1-10       | 225      | 30       | 60 | TR-F      | 58115039      | HW Parat - negatief                    | 1-12       |
| 190      | 30       | 38 | TR-F      | 58116510      | HW Unisteel (HKS)                      | 1-11       | 225      | 30       | 64 | WS        | 50687902      | HW HKS - Board                         | 1-7        |
| 190      | 30       | 48 | WS        | 50110090      | HW HKS - Board                         | 1-13, 1-7  | 230      | 30       | 4  | F         | 50457992      | DP HKS - LR                            | 1-7        |
| 190      | 30       | 48 | F-WS      | 58110418      | HW HKS - Massief - Accuhandcirkelzagen | 1-1        | 230      | 30       | 6  | F-FA      | 58458793      | DP HKS - L2                            | 1-9        |
| 190      | 30       | 48 | TR-F      | 58458785      | HT HKS - Mega-Steel                    | 1-3        | 230      | 30       | 15 | F         | 50457359      | DP HKS - L                             | 1-8        |
| 190      | 30       | 54 | TR-F      | 58115010      | HW Parat - negatief                    | 1-12, 1-13 | 230      | 30       | 18 | WS        | 50110255      | HW HKS - Massief                       | 1-6        |
| 190      | 30       | 54 | WS-FA     | 58116001      | HW KKS - Plastic                       | 1-55       | 230      | 30       | 24 | WS        | 50110168      | HW HKS - Massief                       | 1-6        |
| 190      | 30       | 56 | TR-F      | 58458779      | HW TRF                                 | 1-24       | 230      | 30       | 30 | F         | 50457362      | DP HKS - L                             | 1-8        |
| 190      | 30       | 60 | WS        | 50110091      | HW HKS - Board                         | 1-7        | 230      | 30       | 36 | WS        | 50110113      | HW HKS - Massief                       | 1-6        |
| 200      | 20       | 30 | KO-F      | 50750125      | DP RSK                                 | 1-44       | 230      | 30       | 44 | TR-F      | 58116514      | HW Unisteel (HKS)                      | 1-11       |
| 200      | 20       | 36 | KO-F      | 50750147      | DP RSK                                 | 1-44       | 230      | 30       | 48 | WS        | 50110114      | HW HKS - Board                         | 1-7        |
| 200      | 20       | 36 | KO-F      | 58803073      | HW RSK - nn-System                     | 1-43       | 230      | 30       | 60 | HR        | 58459770      | DP HKS - nn-System DP flex             | 1-10       |
| 200      | 30       | 18 | WS        | 50110252      | HW HKS - Massief                       | 1-5        |          |          |    |           |               |  |            |
| 200      | 30       | 30 | WS        | 50110095      | HW HKS - Massief                       | 1-5        |          |          |    |           |               |  |            |
| 200      | 30       | 34 | WS        | 58100017      | HW ZQW                                 | 1-20       |          |          |    |           |               |  |            |

# Diameter-index cirkelzaagbladen

| Ø D [mm] | Ø d [mm] | Z  | Tand-vorm       | Bestel-nummer | Programma | Pagina   | Ø D [mm]   | Ø d [mm] | Z    | Tand-vorm | Bestel-nummer | Programma | Pagina |  |            |
|----------|----------|----|-----------------|---------------|-----------|--|------------|----------|------|-----------|---------------|-----------|--------|--|------------|
| 230      | 30       | 60 | TR-F            | 58805879      | HT        | HKS - Mega-Steel                                 | 1-3        | 254      | 30   | 80        | TR-F          | 58808246  | HW     | NE-negatief                                      | 1-49       |
| 230      | 30       | 64 | WS              | 50110115      | HW        | HKS - Board                                      | 1-7        | 254      | 30   | 80        | TR-TR         | 58808612  | HW     | KKS - hard plastic negatief                      | 1-57       |
| 230      | 30       | 64 | TR-F            | 58115014      | HW        | Parat - negatief                                 | 1-12       | 260      | 30   | 8         | F-FA          | 58458797  | DP     | HKS - L2   | 1-9        |
| 232      | 30       | 64 | TR-F            | 58458781      | HW        | TRF  | 1-24       | 260      | 30   | 32        | WS            | 58110185  | HW     | ZQW  | 1-20       |
| 232      | 30       | 72 | WS-FA           | 58116003      | HW        | KKS - Plastic                                    | 1-55       | 260      | 30   | 40        | WS            | 58110175  | HW     | ZWS  | 1-21       |
| 235      | 30       | 16 | F-FA            | 58112015      | HW        | BKS (NAIL)                                       | 1-16       | 260      | 30   | 60        | WS            | 58100233  | HW     | K + G negatief                                   | 1-15       |
| 235      | 30       | 18 | WS              | 50110256      | HW        | ZQW  | 1-20       | 260      | 30   | 60        | WS            | 58100254  | HW     | ZWS  | 1-21       |
| 235      | 30       | 24 | WS              | 50110170      | HW        | ZQW  | 1-14, 1-20 | 260      | 30   | 60        | F-WFA         | 58165010  | HW     | Unisteel   | 1-52       |
| 235      | 30       | 24 | WS              | 58100191      | HW        | ZQW  | 1-20       | 260      | 30   | 72        | TR-F          | 58808206  | HW     | NE-negatief                                      | 1-49       |
| 235      | 30       | 34 | WS              | 50100193      | HW        | ZWS  | 1-21       | 260      | 30   | 80        | WS            | 58100234  | HW     | K + G negatief                                   | 1-15       |
| 235      | 30       | 36 | WS              | 50110117      | HW        | ZWS  | 1-21       | 260      | 30   | 80        | TR-TR         | 58808613  | HW     | KKS - hard plastic negatief                      | 1-57       |
| 235      | 30       | 44 | TR-F            | 58116521      | HW        | Unisteel (HKS)                                   | 1-11       | 270      | 30   | 18        | F             | 58114170  | HW     | ZFL  | 1-17       |
| 235      | 30       | 48 | WS              | 58110121      | HW        | ZWS  | 1-14, 1-21 | 270      | 30   | 24        | WS            | 58110176  | HW     | ZQW  | 1-20       |
| 235      | 30       | 64 | WS              | 58110118      | HW        | ZWS  | 1-21       | 270      | 30   | 42        | WS            | 50110064  | HW     | ZWS  | 1-21       |
| 235      | 30       | 64 | TR-F            | 58115018      | HW        | NE-negatief                                      | 1-14, 1-49 | 270      | 30   | 54        | F-WFA         | 58116517  | HW     | Unisteel   | 1-52       |
| 240      | 30       | 24 | WS              | 50110174      | HW        | ZQW  | 1-20       | 270      | 30   | 60        | WS            | 58110182  | HW     | ZWS  | 1-21       |
| 240      | 30       | 36 | WS              | 50110123      | HW        | ZWS  | 1-21       | 280      | 30   | 48        | WS            | 58110136  | HW     | ZWS  | 1-21       |
| 240      | 30       | 44 | TR-F            | 58116515      | HW        | Unisteel (HKS)                                   | 1-11       | 280      | 30   | 85        | F-WS-WS       | 58808705  | HW     | Matador 5  | 1-23       |
| 240      | 30       | 48 | WS              | 50110124      | HW        | ZWS  | 1-21       | 300      | 30   | 100       | F-WS-WS       | 58808708  | HW     | Matador 5  | 1-23       |
| 240      | 30       | 64 | WS              | 50687903      | HW        | HKS - Massief                                    | 1-6        | 300      | 30   | 100       | F-WS-WS       | 58808713  | HW     | Matador 5  | 1-23       |
| 240      | 30       | 75 | F-WS-WS         | 58808704      | HW        | Matador 5  | 1-23       | 300      | 30   | 20        | F-FA          | 58120041  | HW     | BKS (NAIL)                                       | 1-16       |
| 250      | 30       | 6  | F-FA            | 58458794      | DP        | HKS - L2   | 1-9        | 300      | 30   | 24        | WS            | 58120002  | HW     | ZQW  | 1-20       |
| 250      | 30       | 16 | F               | 50457360      | DP        | HKS - L  | 1-8        | 300      | 30   | 28        | WS            | 58102002  | HW     | ZW   | 1-19       |
| 250      | 30       | 16 | F-FA            | 58120220      | HW        | BKS (NAIL)                                       | 1-16       | 300      | 30   | 36        | F             | 50457557  | DP     | HKS - L  | 1-8        |
| 250      | 30       | 18 | F               | 58104050      | HW        | ZFL  | 1-17       | 300      | 30   | 36        | WS            | 58120013  | HW     | ZQW  | 1-20       |
| 250      | 30       | 24 | WS              | 58102001      | HW        | ZW   | 1-19       | 300      | 30   | 48        | F             | 50457545  | DP     | HKS - L  | 1-8        |
| 250      | 30       | 24 | F-WS            | 58110412      | HW        | HKS - Massief - Accuhandcirkelzagen              | 1-1        | 300      | 30   | 48        | WS            | 58100250  | HW     | ZWS  | 1-21       |
| 250      | 30       | 24 | WS              | 58120060      | HW        | ZQW  | 1-14, 1-20 | 300      | 30   | 48        | WS            | 58100702  | HW     | ZWS  | 1-22       |
| 250      | 30       | 30 | ES-F + F + ES-F | 50459024      | HW        | NK3VS  | 2-7        | 300      | 30   | 60        | WS            | 58100027  | HW     | ZWS  | 1-21       |
| 250      | 30       | 30 | WS              | 58120061      | HW        | ZQW  | 1-20       | 300      | 30   | 60        | TR-F          | 58806053  | HW     | TFP  | 1-41       |
| 250      | 30       | 40 | F               | 50458000      | DP        | HKS - L  | 1-8        | 300      | 30   | 72        | WS            | 58100032  | HW     | ZWS  | 1-21       |
| 250      | 30       | 40 | WS              | 58100018      | HW        | ZWS  | 1-14, 1-21 | 300      | 30   | 72        | TR-F          | 58100387  | HW     | TRF  | 1-24, 1-26 |
| 250      | 30       | 40 | WS              | 58100700      | HW        | ZWS  | 1-22       | 300      | 30   | 72        | TR-F          | 58808104  | HW     | NE-positief                                      | 1-48       |
| 250      | 30       | 40 | WS              | 58120020      | HW        | ZQW  | 1-20       | 300      | 30   | 72        | TR-F          | 58808209  | HW     | NE-negatief                                      | 1-49       |
| 250      | 30       | 48 | WS              | 58100026      | HW        | ZWS  | 1-21       | 300      | 30   | 84        | TR-F          | 58808244  | HW     | NE-negatief                                      | 1-49       |
| 250      | 30       | 48 | DA-F DU         | 58804351      | HW        | KDF - Industry                                   | 1-32       | 300      | 30   | 96        | WS-FA         | 50808501  | HW     | KKS - Plastic                                    | 1-55       |
| 250      | 30       | 48 | DA-F DU         | 58804352      | HW        | KDF - Industry - Negativ                         | 1-31       | 300      | 30   | 96        | WS            | 58100251  | HW     | ZWS  | 1-21       |
| 250      | 30       | 50 | HR              | 58459455      | DP        | HRP - nn-System DP flex                          | 1-34       | 300      | 30   | 96        | TR-F          | 58100388  | HW     | TRF  | 1-24       |
| 250      | 30       | 60 | WS              | 58100031      | HW        | ZWS  | 1-21       | 300      | 30   | 96        | WS            | 58100703  | HW     | ZWS  | 1-22       |
| 250      | 30       | 60 | TR-F            | 58100385      | HW        | TRF  | 1-24       | 300      | 30   | 96        | TR-F          | 58458788  | HW     | TRF - 1  | 1-25       |
| 250      | 30       | 60 | WS              | 58100701      | HW        | ZWS  | 1-22       | 300      | 30   | 96        | TR-F          | 58808107  | HW     | NE-positief                                      | 1-48       |
| 250      | 30       | 60 | TR-F            | 58808201      | HW        | NE-negatief                                      | 1-49       | 300      | 30   | 96        | TR-F          | 58808213  | HW     | NE-negatief                                      | 1-49       |
| 250      | 30       | 72 | TR-F-FA         | 50808600      | HW        | KKS - Hard plastic                               | 1-57       | 300      | 30   | 96        | TR-F          | 58808214  | HW     | NE-negatief                                      | 1-49       |
| 250      | 30       | 80 | WS-FA           | 50808500      | HW        | KKS - Plastic                                    | 1-55       | 300      | 30   | 96        | TR-F          | 58808621  | HW     | KKS - Hard plastic                               | 1-56       |
| 250      | 30       | 80 | WS              | 58100038      | HW        | ZWS  | 1-21       | 300      | 30   | 98        | G7            | 58192568  | HW     | NE-Kapcirkelzaagblad HW - Negativ - profiel 'G7' | 1-51       |
| 250      | 30       | 80 | TR-F            | 58100386      | HW        | TRF  | 1-24       | 300      | 30   | 98        | G7            | 58192663  | HW     | NE-Kapcirkelzaagblad HW - Positiv - profiel 'G7' | 1-50       |
| 250      | 30       | 80 | TR-F            | 58808102      | HW        | NE-positief                                      | 1-48       | 300      | 32   | 96        | TR-F          | 58808125  | HW     | NE-positief                                      | 1-48       |
| 250      | 30       | 80 | TR-F            | 58808200      | HW        | NE-negatief                                      | 1-49       | 300      | 32   | 96        | TR-F          | 58808215  | HW     | NE-negatief                                      | 1-49       |
| 250      | 30       | 80 | TR-F            | 58808203      | HW        | NE-negatief                                      | 1-14, 1-49 | 300      | 40   | 72        | WS            | 58100237  | HW     | K + G negatief                                   | 1-15       |
| 250      | 30       | 80 | TR-F            | 58808620      | HW        | KKS - Hard plastic                               | 1-56       | 300      | 40   | 96        | TR-F          | 58808216  | HW     | NE-negatief                                      | 1-49       |
| 250      | 30       | 80 | F-WS-WS         | 58808706      | HW        | Matador 5  | 1-23       | 300      | 70   | 22        | F             | 50100525  | HW     | LWR  | 1-47       |
| 250      | 30       | 84 | G7              | 58192965      | HW        | NE-Kapcirkelzaagblad HW - Negativ - profiel 'G7' | 1-51       | 303      | 30   | 100       | F-WS-WS       | 58808707  | HW     | Matador 5  | 1-23       |
| 250      | 32       | 60 | TR-F            | 58808202      | HW        | NE-negatief                                      | 1-49       | 303      | 30   | 60        | HR            | 58459439  | DP     | HRP - nn-System DP flex                          | 1-34       |
| 250      | 32       | 80 | TR-F            | 58808204      | HW        | NE-negatief                                      | 1-49       | 303      | 30   | 60        | DA-F DU       | 58804279  | HW     | KDF - Industry - Negativ                         | 1-31       |
| 250      | 40       | 80 | TR-F            | 58808205      | HW        | NE-negatief                                      | 1-49       | 303      | 30   | 60        | TR-F-F DU     | 58804282  | HW     | KDF - Industry professioneel                     | 1-33       |
| 250      | 70       | 20 | F               | 50457841      | HW        | LWR  | 1-47       | 303      | 30   | 60        | DA-F FA DU    | 58804301  | HW     | KDF - PTFE                                       | 1-32       |
| 254      | 20/30    | 40 | WS              | 58114108      | HW        | ZWS  | 1-21       | 303      | 30   | 60        | DA-F DU       | 58804353  | HW     | KDF - Industry                                   | 1-32       |
| 254      | 25,4     | 72 | F-WFA           | 58805870      | HT        | Mega-Steel                                       | 1-54       | 305      | 25,4 | 60        | F-WFA         | 50805872  | HT     | Mega-Steel                                       | 1-54       |
| 254      | 30       | 24 | WS              | 58118119      | HW        | K + G negatief                                   | 1-15       | 305      | 25,4 | 60        | F-WFA         | 58805862  | HW     | Steel  | 1-53       |
| 254      | 30       | 40 | WS              | 58100218      | HW        | K + G negatief                                   | 1-15       | 305      | 25,4 | 80        | F-WFA         | 50805873  | HT     | Mega-Steel                                       | 1-54       |
| 254      | 30       | 40 | WS              | 58120067      | HW        | ZWS  | 1-21       | 305      | 25,4 | 80        | F-WFA         | 58805863  | HW     | Steel  | 1-53       |
| 254      | 30       | 48 | F-WFA           | 58165001      | HW        | Unisteel   | 1-52       | 305      | 30   | 32        | WS            | 58110270  | HW     | K + G negatief                                   | 1-15       |
| 254      | 30       | 60 | WS              | 58100231      | HW        | K + G negatief                                   | 1-15       | 305      | 30   | 48        | WS            | 58120065  | HW     | ZWS  | 1-21       |
| 254      | 30       | 60 | WS              | 58120068      | HW        | ZWS  | 1-21       | 305      | 30   | 60        | WS            | 58110281  | HW     | K + G negatief                                   | 1-15       |
| 254      | 30       | 60 | F-WFA           | 58805861      | HW        | Steel  | 1-53       | 305      | 30   | 60        | WS            | 58120066  | HW     | ZWS  | 1-21       |
| 254      | 30       | 72 | F-WFA           | 58805871      | HT        | Mega-Steel                                       | 1-54       | 305      | 30   | 60        | F-WFA         | 58165002  | HW     | Unisteel   | 1-52       |
| 254      | 30       | 80 | WS              | 58110139      | HW        | K + G negatief                                   | 1-15       | 305      | 30   | 60        | TR-F          | 58808241  | HW     | NE-negatief                                      | 1-49       |
|          |          |    |                 |               |           |  |            | 305      | 30   | 8         | F-FA          | 58458795  | DP     | HKS - L2   | 1-9        |
|          |          |    |                 |               |           |  |            | 305      | 30   | 80        | F-WFA         | 50805874  | HT     | Mega-Steel                                       | 1-54       |
|          |          |    |                 |               |           |  |            | 305      | 30   | 80        | F-WFA         | 58805864  | HW     | Steel  | 1-53       |



# Diameter-index cirkelzaagbladen

| Ø D [mm] | Ø d [mm] | Z   | Tand-vorm | Bestel-nummer | Programma   | Pagina     | Ø D [mm] | Ø d [mm] | Z   | Tand-vorm | Bestel-nummer | Programma   | Pagina |
|----------|----------|-----|-----------|---------------|---|------------|----------|----------|-----|-----------|---------------|---|--------|
| 305      | 30       | 96  | WS        | 58110272      | HW K + G negatief                                   | 1-15       | 380      | 32       | 110 | TR-F      | 58808243      | HW NE-negatief                                      | 1-49   |
| 305      | 30       | 96  | TR-F      | 58808245      | HW NE-negatief                                      | 1-49       | 380      | 32       | 112 | G7        | 58192567      | HW NE-Kapcirkelzaagblad HW - Negativ - profiel 'G7' | 1-51   |
| 305      | 30       | 96  | TR-TR     | 58808614      | HW KKS - hard plastic negatief                      | 1-57       | 380      | 60       | 72  | TR-F-FA   | 50750130      | DP TFP  | 1-42   |
| 315      | 30       | 10  | F-FA      | 58458801      | DP HKS - L2   | 1-9        | 380      | 60       | 72  | TR-F-FA   | 50750131      | DP TFP  | 1-42   |
| 315      | 30       | 14  | F         | 58104055      | HW ZFL  | 1-17       | 380      | 60       | 72  | TR-F      | 58806065      | HW TFP  | 1-41   |
| 315      | 30       | 20  | F-FA      | 58120046      | HW BKS (NAIL)                                       | 1-16       | 400      | 30       | 108 | TR-F      | 58808623      | HW KKS - Hard plastic                               | 1-56   |
| 315      | 30       | 28  | WS        | 58102003      | HW ZW   | 1-19       | 400      | 30       | 120 | WS        | 58100041      | HW ZWS  | 1-21   |
| 315      | 30       | 28  | WS        | 58120062      | HW ZQW  | 1-20       | 400      | 30       | 15  | F-FA      | 58458798      | DP HKS - L2   | 1-9    |
| 315      | 30       | 36  | WS        | 58100255      | HW ZQW  | 1-20       | 400      | 30       | 18  | F         | 58104021      | HW ZFL  | 1-17   |
| 315      | 30       | 48  | WS        | 58100252      | HW ZWS  | 1-21       | 400      | 30       | 28  | WS        | 50804423      | HW Planet   | 1-46   |
| 315      | 30       | 60  | WS        | 58100253      | HW ZWS  | 1-21       | 400      | 30       | 28  | WS        | 58100005      | HW ZQW  | 1-20   |
| 315      | 30       | 84  | WS        | 58110274      | HW K + G negatief                                   | 1-15       | 400      | 30       | 28  | WS        | 58100183      | HW ZWZ  | 1-18   |
| 315      | 30       | 96  | TR-F      | 58803823      | HW TRF - 1  | 1-25       | 400      | 30       | 28  | F-FA      | 58120043      | HW BKS (NAIL)                                       | 1-16   |
| 320      | 25,4     | 84  | F-WFA     | 58805859      | HW Steel  | 1-53       | 400      | 30       | 32  | WS        | 58120008      | HW ZQW  | 1-20   |
| 320      | 65       | 60  | TR-F-FA   | 50750120      | DP TFP  | 1-42       | 400      | 30       | 36  | WS        | 58100012      | HW ZQW  | 1-20   |
| 330      | 30       | 24  | WS        | 58120018      | HW ZQW  | 1-20       | 400      | 30       | 36  | WS        | 58100034      | HW ZW   | 1-19   |
| 330      | 30       | 54  | F-WFA     | 58165005      | HW Unisteel   | 1-52       | 400      | 30       | 48  | WS        | 58120017      | HW ZQW  | 1-20   |
| 330      | 30       | 90  | F-WFA     | 50805875      | HT Mega-Steel                                       | 1-54       | 400      | 30       | 60  | WS        | 58100022      | HW ZWS  | 1-21   |
| 330      | 30       | 90  | F-WFA     | 58805865      | HW Steel  | 1-53       | 400      | 30       | 72  | TR-F-FA   | 50750132      | DP TFP  | 1-42   |
| 330      | 30       | 96  | TR-F      | 58808217      | HW NE-negatief                                      | 1-49       | 400      | 30       | 72  | TR-F      | 58806069      | HW TFP  | 1-41   |
| 330      | 32       | 96  | TR-F      | 58808218      | HW NE-negatief                                      | 1-49       | 400      | 30       | 84  | WS        | 58100029      | HW ZWS  | 1-21   |
| 335      | 30       | 36  | WS        | 58120063      | HW ZQW  | 1-20       | 400      | 30       | 84  | F-WFA     | 58165004      | HW Unisteel   | 1-52   |
| 350      | 30       | 100 | WS-FA     | 50808502      | HW KKS - Plastic                                    | 1-55       | 400      | 30       | 96  | WS        | 58100034      | HW ZWS  | 1-21   |
| 350      | 30       | 100 | F-WS-WS   | 58808709      | HW Matador 5  | 1-23       | 400      | 30       | 96  | TR-F      | 58808113      | HW NE-positief                                      | 1-48   |
| 350      | 30       | 108 | WS        | 58100040      | HW ZWS  | 1-21       | 400      | 30       | 96  | TR-F      | 58808232      | HW NE-negatief                                      | 1-49   |
| 350      | 30       | 108 | TR-F      | 58100389      | HW TRF  | 1-24       | 400      | 30       | 98  | G7        | 58192276      | HW NE-Kapcirkelzaagblad HW - Negativ - profiel 'G7' | 1-51   |
| 350      | 30       | 108 | TR-F      | 58807831      | HW TRF - 1  | 1-25       | 400      | 30       | 98  | G7        | 58192277      | HW NE-Kapcirkelzaagblad HW - Negativ - profiel 'G7' | 1-51   |
| 350      | 30       | 108 | TR-F      | 58808111      | HW NE-positief                                      | 1-48       | 400      | 30       | 98  | G7        | 58192269      | HW NE-Kapcirkelzaagblad HW - Positiv - profiel 'G7' | 1-50   |
| 350      | 30       | 108 | TR-F      | 58808225      | HW NE-negatief                                      | 1-49       | 400      | 75       | 72  | TR-F-FA   | 50750133      | DP TFP  | 1-42   |
| 350      | 30       | 108 | TR-F      | 58808622      | HW KKS - Hard plastic                               | 1-56       | 400      | 75       | 72  | TR-F      | 58806071      | HW TFP  | 1-41   |
| 350      | 30       | 112 | G7        | 58192275      | HW NE-Kapcirkelzaagblad HW - Negativ - profiel 'G7' | 1-51       | 400      | 80       | 72  | TR-F-FA   | 50750134      | DP TFP  | 1-42   |
| 350      | 30       | 12  | F-FA      | 58458802      | DP HKS - L2   | 1-9        | 400      | 80       | 72  | TR-F      | 58807809      | HW TFP  | 1-41   |
| 350      | 30       | 16  | F         | 58104015      | HW ZFL  | 1-17       | 410      | 30       | 28  | WS        | 58120019      | HW ZQW  | 1-20   |
| 350      | 30       | 24  | WS        | 50804422      | HW Planet   | 1-46       | 420      | 30       | 96  | TR-F      | 58808115      | HW NE-positief                                      | 1-48   |
| 350      | 30       | 24  | F         | 58104041      | HW ZFL  | 1-17       | 420      | 30       | 96  | TR-F      | 58808234      | HW NE-negatief                                      | 1-49   |
| 350      | 30       | 24  | WS        | 58120005      | HW ZQW  | 1-20       | 420      | 30       | 98  | G7        | 58192277      | HW NE-Kapcirkelzaagblad HW - Negativ - profiel 'G7' | 1-51   |
| 350      | 30       | 24  | F-FA      | 58120042      | HW BKS (NAIL)                                       | 1-16       | 420      | 30       | 98  | G7        | 58192266      | HW NE-Kapcirkelzaagblad HW - Positiv - profiel 'G7' | 1-50   |
| 350      | 30       | 32  | WS        | 58100011      | HW ZQW  | 1-20       | 420      | 40       | 100 | TR-F      | 58808236      | HW NE-negatief                                      | 1-49   |
| 350      | 30       | 32  | WS        | 58101004      | HW ZW   | 1-19       | 420      | 40       | 54  | WS        | 58110145      | HW K + G negatief                                   | 1-15   |
| 350      | 30       | 36  | WS        | 58120014      | HW ZQW  | 1-20       | 420      | 40       | 84  | WS        | 58110144      | HW K + G negatief                                   | 1-15   |
| 350      | 30       | 42  | WS        | 58120015      | HW ZQW  | 1-20       | 420      | 60       | 60  | TR-F-FA   | 50750135      | DP TFP  | 1-42   |
| 350      | 30       | 54  | WS        | 58100021      | HW ZWS  | 1-21       | 420      | 60       | 72  | TR-F      | 58807956      | HW TFP  | 1-41   |
| 350      | 30       | 54  | WS        | 58100704      | HW ZWS  | 1-22       | 430      | 80       | 72  | TR-F      | 58806479      | HW TFP  | 1-41   |
| 350      | 30       | 72  | TR-F-FA   | 50750128      | DP TFP  | 1-42       | 450      | 30       | 108 | WS        | 58100060      | HW ZWS  | 1-22   |
| 350      | 30       | 72  | TR-F-FA   | 50750129      | DP TFP  | 1-42       | 450      | 30       | 112 | G7        | 58192278      | HW NE-Kapcirkelzaagblad HW - Negativ - profiel 'G7' | 1-51   |
| 350      | 30       | 72  | WS        | 58100028      | HW ZWS  | 1-21       | 450      | 30       | 20  | WS        | 58101020      | HW ZW   | 1-19   |
| 350      | 30       | 72  | TR-F      | 58100300      | HW TRF  | 1-24       | 450      | 30       | 30  | F-FA      | 58120044      | HW BKS (NAIL)                                       | 1-16   |
| 350      | 30       | 72  | HR        | 58459446      | DP HRP - nn-System DP flex                          | 1-34       | 450      | 30       | 32  | F         | 58104051      | HW ZFL  | 1-17   |
| 350      | 30       | 72  | DA-F DU   | 58804280      | HW KDF - Industry                                   | 1-32       | 450      | 30       | 36  | WS        | 50804425      | HW Planet   | 1-46   |
| 350      | 30       | 72  | TR-F      | 58807803      | HW TFP  | 1-41       | 450      | 30       | 40  | WS        | 58100013      | HW ZQW  | 1-20   |
| 350      | 30       | 72  | TR-F      | 58807830      | HW TRF - 1  | 1-25, 1-26 | 450      | 30       | 40  | WS        | 58101006      | HW ZW   | 1-19   |
| 350      | 30       | 84  | WS        | 58100033      | HW ZWS  | 1-21       | 450      | 30       | 66  | WS        | 58100023      | HW ZWS  | 1-22   |
| 350      | 30       | 90  | TR-F      | 58808222      | HW NE-negatief                                      | 1-49       | 450      | 30       | 72  | TR-F-FA   | 50750138      | DP TFP  | 1-42   |
| 350      | 30       | 98  | G7        | 58192274      | HW NE-Kapcirkelzaagblad HW - Negativ - profiel 'G7' | 1-51       | 450      | 30       | 72  | TR-F      | 58458789      | HW TFP  | 1-41   |
| 350      | 30       | 98  | G7        | 58192262      | HW NE-Kapcirkelzaagblad HW - Positiv - profiel 'G7' | 1-50       | 450      | 30       | 90  | F-WFA     | 58165006      | HW Unisteel   | 1-52   |
| 350      | 32       | 108 | TR-F      | 58808226      | HW NE-negatief                                      | 1-49       | 450      | 30       | 96  | TR-F      | 58808235      | HW NE-negatief                                      | 1-49   |
| 350      | 40       | 108 | TR-F      | 58808227      | HW NE-negatief                                      | 1-49       | 450      | 40       | 108 | TR-F      | 58808117      | HW NE-positief                                      | 1-48   |
| 350      | 40       | 72  | WS        | 58110273      | HW K + G negatief                                   | 1-15       | 450      | 60       | 72  | TR-F-FA   | 50750136      | DP TFP  | 1-42   |
| 350      | 40       | 84  | G7        | 58192273      | HW NE-Kapcirkelzaagblad HW - Negativ - profiel 'G7' | 1-51       | 450      | 60       | 72  | TR-F      | 58807817      | HW TFP  | 1-41   |
| 350      | 60       | 72  | TR-F      | 58807955      | HW TFP  | 1-41       | 450      | 80       | 72  | TR-F-FA   | 50750137      | DP TFP  | 1-42   |
| 350      | 70       | 20  | F         | 50100528      | HW LWR  | 1-47       | 460      | 30       | 72  | TR-F-FA   | 50750146      | DP TFP  | 1-42   |
| 350      | 70       | 28  | F         | 50457843      | HW LWR  | 1-47       | 480      | 30       | 72  | TR-F-FA   | 50750139      | DP TFP  | 1-42   |
| 355      | 25,4     | 80  | F-WFA     | 50805876      | HT Mega-Steel                                       | 1-54       | 480      | 60       | 72  | TR-F-FA   | 50750140      | DP TFP  | 1-42   |
| 355      | 25,4     | 80  | F-WFA     | 58805866      | HW Steel  | 1-53       | 500      | 30       | 120 | TR-F      | 58808118      | HW NE-positief                                      | 1-48   |
| 355      | 25,4     | 90  | F-WFA     | 50805878      | HT Mega-Steel                                       | 1-54       | 500      | 30       | 120 | TR-F      | 58808239      | HW NE-negatief                                      | 1-49   |
| 355      | 25,4     | 90  | F-WFA     | 58805868      | HW Steel  | 1-53       |          |          |     |           |               |   |        |
| 355      | 30       | 80  | F-WFA     | 58165003      | HW Unisteel   | 1-52       |          |          |     |           |               |   |        |
| 355      | 30       | 90  | F-WFA     | 50805877      | HT Mega-Steel                                       | 1-54       |          |          |     |           |               |   |        |
| 355      | 30       | 90  | F-WFA     | 58805867      | HW Steel  | 1-53       |          |          |     |           |               |   |        |
| 355      | 30       | 96  | WS        | 58110143      | HW K + G negatief                                   | 1-15       |          |          |     |           |               |   |        |
| 355      | 75       | 72  | TR-F      | 58807888      | HW TFP  | 1-41       |          |          |     |           |               |   |        |

## Diameter-index cirkelzaagbladen

| Ø D [mm] | Ø d [mm] | Z   | Tand-vorm | Bestel-nummer |    | Programma  | Pagina |
|----------|----------|-----|-----------|---------------|----|--|--------|
| 500      | 30       | 126 | G7        | 58192279      | HW | NE-Kapcirkelzaagblad HW - Negativ - profiel 'G7' | 1-51   |
| 500      | 30       | 126 | G7        | 58192661      | HW | NE-Kapcirkelzaagblad HW - Positiv - profiel 'G7' | 1-50   |
| 500      | 30       | 144 | WS        | 50807842      | HW | OKW  | 1-46   |
| 500      | 30       | 145 | F-WS-WS   | 58808710      | HW | Matador 5  | 1-23   |
| 500      | 30       | 34  | F-FA      | 58120045      | HW | BKS (NAIL)                                       | 1-16   |
| 500      | 30       | 36  | F         | 58104052      | HW | ZFL  | 1-17   |
| 500      | 30       | 44  | WS        | 58100014      | HW | ZQW  | 1-20   |
| 500      | 30       | 44  | WS        | 58102007      | HW | ZW   | 1-19   |
| 500      | 30       | 72  | WS        | 58100024      | HW | ZWS  | 1-22   |
| 550      | 30       | 133 | G7        | 58192392      | HW | NE-Kapcirkelzaagblad HW - Negativ - profiel 'G7' | 1-51   |
| 550      | 30       | 160 | F-WS-WS   | 58808711      | HW | Matador 5  | 1-23   |
| 550      | 30       | 32  | F         | 58104054      | HW | ZFL  | 1-17   |
| 550      | 30       | 64  | WS        | 58120070      | HW | ZWS  | 1-22   |
| 600      | 30       | 36  | F-FA      | 58120227      | HW | BKS (NAIL)                                       | 1-16   |
| 600      | 30       | 40  | F         | 58104048      | HW | ZFL  | 1-17   |
| 600      | 30       | 54  | WS        | 58101018      | HW | ZW   | 1-19   |
| 700      | 30       | 42  | F         | 58104053      | HW | ZFL  | 1-17   |
| 700      | 30       | 42  | F-FA      | 58120228      | HW | BKS (NAIL)                                       | 1-16   |
| 700      | 30       | 46  | F         | 58104049      | HW | ZFL  | 1-17   |
| 700      | 30       | 60  | WS        | 58101019      | HW | ZW   | 1-19   |

# Diameter-index boorfreese

| Ø D [mm] | Ø d [mm] | B [mm] | Z      | Bestelnummer | Programma   | Pagina | Ø D [mm] | Ø d [mm] | B [mm] | Z    | Bestelnummer | Programma                                    | Pagina |
|----------|----------|--------|--------|--------------|---|--------|----------|----------|--------|------|--------------|--|--------|
| 57       | 16       |        | 2      | 50811739     | DP 3565-1 Edge Rounding Cutters                       | 2-18   | 100      | 30       | 64     | 3+3  | 50186074     | 3588-2 Groefmeskoppen airFace DP             | 2-16   |
| 57       | 16       |        | 2      | 50811740     | DP 3565-1 Edge Rounding Cutters                       | 2-18   | 100      | 30       | 64,5   | 2+2  | 58186387     | DP 3585 Voegenfrees DP airFace               | 2-13   |
| 58.7     | 16       |        | 3      | 50182686     | DP 3565-2 Kanten-afroundfrees CM                      | 2-19   | 100      | 30       | 64,5   | 2+2  | 58186388     | DP 3585 Voegenfrees DP airFace               | 2-13   |
| 58.7     | 16       |        | 3      | 50811743     | DP 3565-2 Kanten-afroundfrees CM                      | 2-19   | 100      | 30       | 64,5   | 3+3  | 58186371     | DP 3585 Voegenfrees DP airFace               | 2-13   |
| 60       | 25       | 64,5   | 2+2    | 58186381     | DP 3585 Voegenfrees DP airFace                        | 2-13   | 100      | 30       | 64,5   | 3+3  | 58186372     | DP 3585 Voegenfrees DP airFace               | 2-13   |
| 60       | 25       | 64,5   | 2+2    | 58186382     | DP 3585 Voegenfrees DP airFace                        | 2-13   | 100.4    | 22       | 7,0    | 3    | 50660347     | DP 3104L Groeffrees - voor Lamello Clamex P® | 2-2    |
| 69       | 16       |        | 4      | 50811737     | DP 3565 Kanten-afroundfrees                           | 2-18   | 100.4    | 30       | 7,0    | 3    | 50660346     | DP 3104L Groeffrees - voor Lamello Clamex P® | 2-2    |
| 69       | 16       |        | 4      | 50811738     | DP 3565 Kanten-afroundfrees                           | 2-18   | 102      | 22       | 3,85   | 12   | 50660301     | HW 1103L Groeffrees - voor Lamello®          | 2-1    |
| 70       | 25       | 43     | 2+2    | 50186037     | 3588-2 Groefmeskoppen airFace DP                      | 2-15   | 102      | 35       | 100    | 2    | 50389263     | HS 464 HS stokkenfreesen                     | 2-38   |
| 70       | 25       | 43     | 2+2    | 50186038     | 3588-2 Groefmeskoppen airFace DP                      | 2-15   | 102      | 35       | 100    | 4    | 50389271     | HS 464 HS stokkenfreesen                     | 2-38   |
| 70       | 30       | 48     | 2+2    | 50811780     | DP 3585-2 voegfrees DP - HOLZ-HER - AirStream-systeem | 2-14   | 102      | 35       | 50     | 2    | 50389261     | HS 464 HS stokkenfreesen                     | 2-38   |
| 70       | 30       | 48     | 2+2    | 50811781     | DP 3585-2 voegfrees DP - HOLZ-HER - AirStream-systeem | 2-14   | 102      | 35       | 50     | 4    | 50389269     | HS 464 HS stokkenfreesen                     | 2-38   |
| 70       | 30       | 64     | 2+2    | 50811782     | DP 3585-2 voegfrees DP - HOLZ-HER - AirStream-systeem | 2-14   | 102      | 35       | 75     | 2    | 50389262     | HS 464 HS stokkenfreesen                     | 2-38   |
| 70       | 30       | 64     | 2+2    | 50811783     | DP 3585-2 voegfrees DP - HOLZ-HER - AirStream-systeem | 2-14   | 102      | 35       | 75     | 4    | 50389270     | HS 464 HS stokkenfreesen                     | 2-38   |
| 70       | 30       | 64     | 2+2    | 50811783     | DP 3585-2 voegfrees DP - HOLZ-HER - AirStream-systeem | 2-14   | 102      | 40       | 100    | 2    | 50389266     | HS 464 HS stokkenfreesen                     | 2-38   |
| 80       | 30       | 100    | 2+2+v2 | 58665106     | HW 5570 Spiraal schaaftoppen                          | 3-28   | 102      | 40       | 100    | 4    | 50389274     | HS 464 HS stokkenfreesen                     | 2-38   |
| 80       | 30       | 43     | 2+2    | 50186031     | 3588-2 Groefmeskoppen airFace DP                      | 2-15   | 102      | 40       | 125    | 2    | 50389275     | HS 464 HS stokkenfreesen                     | 2-38   |
| 80       | 30       | 80     | 2+2+v2 | 58665105     | HW 5570 Spiraal schaaftoppen                          | 3-28   | 102      | 40       | 150    | 2    | 50389268     | HS 464 HS stokkenfreesen                     | 2-38   |
| 85       | 30       | 43,2   | 3+3    | 58186408     | DP 3585 Voegenfrees DP airFace                        | 2-13   | 102      | 40       | 150    | 4    | 50389276     | HS 464 HS stokkenfreesen                     | 2-38   |
| 85       | 30       | 43,2   | 3+3    | 58186409     | DP 3585 Voegenfrees DP airFace                        | 2-13   | 102      | 40       | 50     | 2    | 50389264     | HS 464 HS stokkenfreesen                     | 2-38   |
| 85       | 30       | 48     | 3+3    | 50186057     | 3588-2 Groefmeskoppen airFace DP                      | 2-15   | 102      | 40       | 50     | 4    | 50389272     | HS 464 HS stokkenfreesen                     | 2-38   |
| 85       | 30       | 48     | 3+3    | 50186058     | 3588-2 Groefmeskoppen airFace DP                      | 2-15   | 102      | 40       | 75     | 2    | 50389265     | HS 464 HS stokkenfreesen                     | 2-38   |
| 96       | 30       | 40     | 2      | 69563162     | 1547 Universele Euro-meskoppen - Silverline           | 2-22   | 102      | 40       | 75     | 4    | 50389273     | HS 464 HS stokkenfreesen                     | 2-38   |
| 100      | 22       | 3,95   | 4      | 50660302     | DP 3103L Groeffrees - voor Lamello®                   | 2-1    | 116      | 30       | 40/50  | 2    | 69563160     | 1547 Universele Euro-meskoppen - Silverline  | 2-22   |
| 100      | 22       | 3,97   | 12     | 50110178     | HW 1103L Groeffrees - voor Lamello®                   | 2-1    | 116      | 40       | 40/50  | 2+2  | 69563163     | 1547 Universele Euro-meskoppen - Silverline  | 2-22   |
| 100      | 22       | 3,97   | 4 V4   | 69470022     | HW 1568 Keermessen groeffrees - voor Lamello®         | 2-2    | 116      | 50       | 40/50  | 2    | 69563161     | 1547 Universele Euro-meskoppen - Silverline  | 2-22   |
| 100      | 22       | 4,0    | 6      | 50660300     | HW 1103L Groeffrees - voor Lamello®                   | 2-1    | 120      | 20       | 4,0    | 35   | 50806254     | HW RNK-Matador 5                             | 2-6    |
| 100      | 22       | 7,0    | 6      | 50660303     | HW NKP - Groeffreescirkelzaagbladen - Prisma          | 2-5    | 120      | 20       | 4,0    | 35   | 50806258     | HW RNK-Matador 5                             | 2-6    |
| 100      | 22       | 8,0    | 4      | 50621077     | HW 1103G Harsgalfrees                                 | 2-3    | 120      | 20       | 5,0    | 35   | 50806255     | HW RNK-Matador 5                             | 2-6    |
| 100      | 25       | 43     | 2+2    | 50186071     | 3588-2 Groefmeskoppen airFace DP                      | 2-16   | 120      | 20       | 5,0    | 35   | 50806259     | HW RNK-Matador 5                             | 2-6    |
| 100      | 25       | 43     | 2+2    | 50186072     | 3588-2 Groefmeskoppen airFace DP                      | 2-16   | 120      | 35       | 4,0    | 35   | 50806256     | HW RNK-Matador 5                             | 2-6    |
| 100      | 30       | 43     | 3+3    | 50186063     | 3588-2 Groefmeskoppen airFace DP                      | 2-16   | 120      | 35       | 5,0    | 35   | 50806257     | HW RNK-Matador 5                             | 2-6    |
| 100      | 30       | 43     | 3+3    | 50186064     | 3588-2 Groefmeskoppen airFace DP                      | 2-16   | 122      | 40       | 100    | 4    | 50822783     | 525 Rugvertande profielfrees                 | 2-33   |
| 100      | 30       | 43     | 3+3    | 50186065     | 3588-2 Groefmeskoppen airFace DP                      | 2-16   | 122      | 40       | 130    | 4    | 50822784     | 525 Rugvertande profielfrees                 | 2-33   |
| 100      | 30       | 43     | 3+3    | 50186066     | 3588-2 Groefmeskoppen airFace DP                      | 2-16   | 122      | 40       | 150    | 4    | 50822785     | 525 Rugvertande profielfrees                 | 2-33   |
| 100      | 30       | 43,2   | 2+2    | 58186377     | DP 3585 Voegenfrees DP airFace                        | 2-13   | 122      | 40       | 180    | 4    | 50822786     | 525 Rugvertande profielfrees                 | 2-33   |
| 100      | 30       | 43,2   | 2+2    | 58186378     | DP 3585 Voegenfrees DP airFace                        | 2-13   | 122      | 40       | 230    | 4    | 50822787     | 525 Rugvertande profielfrees                 | 2-33   |
| 100      | 30       | 43,2   | 2+2    | 58186385     | DP 3585 Voegenfrees DP airFace                        | 2-13   | 122      | 40       | 40     | 4    | 50822780     | 525 Rugvertande profielfrees                 | 2-33   |
| 100      | 30       | 43,2   | 2+2    | 58186386     | DP 3585 Voegenfrees                                   | 2-13   | 122      | 40       | 60     | 4    | 50822781     | 525 Rugvertande profielfrees                 | 2-33   |
| 100      | 30       | 43,2   | 3+3    | 58186373     | DP 3585 Voegenfrees DP airFace                        | 2-13   | 122      | 40       | 80     | 4    | 50822782     | 525 Rugvertande profielfrees                 | 2-33   |
| 100      | 30       | 43,2   | 3+3    | 58186374     | DP 3585 Voegenfrees DP airFace                        | 2-13   | 125      | 30       | 1,5    | 12   | 50188359     | HW Groeffrees HW                             | 2-4    |
| 100      | 30       | 43,2   | 3+3    | 58186414     | DP 3585 Voegenfrees DP airFace                        | 2-13   | 125      | 30       | 1,8    | 12   | 50188360     | HW Groeffrees HW                             | 2-4    |
| 100      | 30       | 43,2   | 3+3    | 58186415     | DP 3585 Voegenfrees DP airFace                        | 2-13   | 125      | 30       | 10     | 12   | 50188372     | HW Groeffrees HW                             | 2-4    |
| 100      | 30       | 63     | 3+3    | 50811784     | DP 3585-2 voegfrees DP - HOLZ-HER - AirStream-systeem | 2-14   | 125      | 30       | 2,0    | 12   | 50188361     | HW Groeffrees HW                             | 2-4    |
| 100      | 30       | 63     | 3+3    | 50811785     | DP 3585-2 voegfrees DP - HOLZ-HER - AirStream-systeem | 2-14   | 125      | 30       | 2,2    | 12   | 50188362     | HW Groeffrees HW                             | 2-4    |
| 100      | 30       | 64     | 3+3    | 50186061     | 3588-2 Groefmeskoppen airFace DP                      | 2-16   | 125      | 30       | 2,5    | 12   | 50188363     | HW Groeffrees HW                             | 2-4    |
| 100      | 30       | 64     | 3+3    | 50186062     | 3588-2 Groefmeskoppen airFace DP                      | 2-16   | 125      | 30       | 25     | 2+2  | 50811729     | DP 3584 Voeg-sponningfrees                   | 2-12   |
| 100      | 30       | 64     | 3+3    | 50186073     | 3588-2 Groefmeskoppen airFace DP                      | 2-16   | 125      | 30       | 29     | 3+3  | 58186401     | DP 3585 Voegenfrees DP airFace               | 2-13   |
|          |          |        |        |              |   |        | 125      | 30       | 3,0    | 12   | 50188364     | HW Groeffrees HW                             | 2-4    |
|          |          |        |        |              |   |        | 125      | 30       | 3,5    | 12   | 50188365     | HW Groeffrees HW                             | 2-4    |
|          |          |        |        |              |   |        | 125      | 30       | 30     | 4 V4 | 68010013     | HW 1583-1 Groef- en sponningfreesen          | 2-11   |
|          |          |        |        |              |   |        | 125      | 30       | 32,5   | 3+3  | 58186306     | 3588-2 Groefmeskoppen airFace DP             | 2-16   |
|          |          |        |        |              |   |        | 125      | 30       | 32,5   | 3+3  | 58186307     | 3588-2 Groefmeskoppen airFace DP             | 2-16   |
|          |          |        |        |              |   |        | 125      | 30       | 4,0    | 12   | 50188366     | HW Groeffrees HW                             | 2-4    |
|          |          |        |        |              |   |        | 125      | 30       | 4,0    | 4 V4 | 50660318     | HW 1503 Groeffreesen                         | 2-8    |
|          |          |        |        |              |   |        | 125      | 30       | 4,5    | 12   | 50188367     | HW Groeffrees HW                             | 2-4    |
|          |          |        |        |              |   |        | 125      | 30       | 5,0    | 12   | 50188368     | HW Groeffrees HW                             | 2-4    |
|          |          |        |        |              |   |        | 125      | 30       | 5,0    | 4 V4 | 50660319     | HW 1503 Groeffreesen                         | 2-8    |
|          |          |        |        |              |   |        | 125      | 30       | 6,0    | 12   | 50188369     | HW Groeffrees HW                             | 2-4    |
|          |          |        |        |              |   |        | 125      | 30       | 7,0    | 12   | 50188370     | HW Groeffrees HW                             | 2-4    |
|          |          |        |        |              |   |        | 125      | 30       | 8,0    | 12   | 50188371     | HW Groeffrees HW                             | 2-4    |
|          |          |        |        |              |   |        | 125      | 30       | 43     | 2+2  | 50811300     | DP 3584 Voeg-fels-frees                      | 2-12   |
|          |          |        |        |              |   |        | 125      | 30       | 43     | 3+3  | 50186047     | 3588-2 Groefmeskoppen airFace DP             | 2-16   |
|          |          |        |        |              |   |        | 125      | 30       | 43,2   | 3+3  | 50185970     | 3588-2 Groefmeskoppen airFace DP             | 2-16   |

# Diameter-index boorfreese

| Ø D [mm] | Ø d [mm] | B [mm] | Z        | Bestelnummer | Programma   | Pagina | Ø D [mm] | Ø d [mm] | B [mm] | Z    | Bestelnummer | Programma | Pagina   |      |
|----------|----------|--------|----------|--------------|---|--------|----------|----------|--------|------|--------------|-----------|--|------|
| 125      | 30       | 43,2   | 3+3      | 50185971     | 3588-2 Groefmeskopen airFace DP                     | 2-16   | 140      | 30       | 13-40  | 2    | 68303303     | HW        | 4010 Groef- en veergereed-schappen enkele koppen | 2-43 |
| 125      | 30       | 43,2   | 3+3      | 50186051     | 3588-2 Groefmeskopen airFace DP                     | 2-16   | 140      | 30       | 50     | 4 V4 | 68010043     | HW        | 1586 Groef- en sponningfrenzen - Silverline      | 2-11 |
| 125      | 30       | 43,2   | 3+3      | 50186052     | 3588-2 Groefmeskopen airFace DP                     | 2-16   | 140      | 40       | 13-33  | 2    | 68303401     | HW        | 4010 Groef- en veergereed-schappen enkele koppen | 2-43 |
| 125      | 30       | 43,2   | 3+3      | 58186399     | DP 3585 Voegenfrees DP airFace                      | 2-13   | 140      | 40       | 13-33  | 2    | 68303402     | HW        | 4010 Groef- en veergereed-schappen enkele koppen | 2-43 |
| 125      | 30       | 50     | 2+2 V2+2 | 58665107     | 5576 Groef- en sponning-messenkoppen HW             | 3-29   | 140      | 40       | 13-36  | 2    | 68303404     | HW        | 4010 Groef- en veergereed-schappen enkele koppen | 2-43 |
| 125      | 30       | 50     | 2+2 V2+2 | 58665108     | 5576 Groef- en sponning-messenkoppen HW             | 3-29   | 140      | 40       | 13-36  | 2    | 68303405     | HW        | 4010 Groef- en veergereed-schappen enkele koppen | 2-43 |
| 125      | 30       | 50     | 4 V4     | 68010023     | HW 1586 Groef- en sponning-meskopen - Silverline    | 2-11   | 140      | 40       | 13-36  | 2    | 68303406     | HW        | 4010 Groef- en veergereed-schappen enkele koppen | 2-43 |
| 125      | 30       | 63     | 3+3      | 50186055     | 3588-2 Groefmeskopen airFace DP                     | 2-16   | 140      | 40       | 13-36  | 2    | 68303407     | HW        | 4010 Groef- en veergereed-schappen enkele koppen | 2-43 |
| 125      | 30       | 63     | 3+3      | 50186056     | 3588-2 Groefmeskopen airFace DP                     | 2-16   | 140      | 40       | 13-36  | 2    | 68303408     | HW        | 4010 Groef- en veergereed-schappen enkele koppen | 2-43 |
| 125      | 30       | 64     | 3+3      | 50186048     | 3588-2 Groefmeskopen airFace DP                     | 2-16   | 140      | 40       | 13-40  | 2    | 68303403     | HW        | 4010 Groef- en veergereed-schappen enkele koppen | 2-43 |
| 125      | 30       | 64     | 3+3      | 58186400     | DP 3585 Voegenfrees DP airFace                      | 2-13   | 140      | 40       | 50     | 4 V4 | 68010044     | HW        | 1586 Groef- en sponningfrenzen - Silverline      | 2-11 |
| 125      | 30       | 64,4   | 3+3      | 50185972     | 3588-2 Groefmeskopen airFace DP                     | 2-16   | 140      | 50       | 13-33  | 2    | 68303501     | HW        | 4010 Groef- en veergereed-schappen enkele koppen | 2-43 |
| 125      | 30       | 64,4   | 3+3      | 50185973     | 3588-2 Groefmeskopen airFace DP                     | 2-16   | 140      | 50       | 13-33  | 2    | 68303502     | HW        | 4010 Groef- en veergereed-schappen enkele koppen | 2-43 |
| 125      | 30       | 64,4   | 3+3      | 50186049     | 3588-2 Groefmeskopen airFace DP                     | 2-16   | 140      | 50       | 13-36  | 2    | 68303504     | HW        | 4010 Groef- en veergereed-schappen enkele koppen | 2-43 |
| 125      | 30       | 64,4   | 3+3      | 50186050     | 3588-2 Groefmeskopen airFace DP                     | 2-16   | 140      | 50       | 13-36  | 2    | 68303505     | HW        | 4010 Groef- en veergereed-schappen enkele koppen | 2-43 |
| 125      | 40       | 100    | 2+2      | 50665050     | HW 5570 Spiraal schaafkoppen                        | 2-28   | 140      | 50       | 13-36  | 2    | 68303506     | HW        | 4010 Groef- en veergereed-schappen enkele koppen | 2-43 |
| 125      | 40       | 100    | 4        | 50561038     | HS 556-1 Schaafkoppen                               | 2-29   | 140      | 50       | 13-36  | 2    | 68303507     | HW        | 4010 Groef- en veergereed-schappen enkele koppen | 2-43 |
| 125      | 40       | 130    | 2+2      | 50665101     | HW 5570 Spiraal schaafkoppen                        | 2-28   | 140      | 50       | 13-36  | 2    | 68303508     | HW        | 4010 Groef- en veergereed-schappen enkele koppen | 2-43 |
| 125      | 40       | 130    | 4        | 50561035     | HS 556-1 Schaafkoppen                               | 2-29   | 140      | 50       | 13-36  | 2    | 68303509     | HW        | 4010 Groef- en veergereed-schappen enkele koppen | 2-43 |
| 125      | 40       | 150    | 4        | 50561036     | HS 556-1 Schaafkoppen                               | 2-29   | 140      | 50       | 13-40  | 2    | 68303503     | HW        | 4010 Groef- en veergereed-schappen enkele koppen | 2-43 |
| 125      | 40       | 170    | 2+2      | 50665102     | HW 5570 Spiraal schaafkoppen                        | 2-28   | 140      | 50       | 13-36  | 2    | 68303504     | HW        | 4010 Groef- en veergereed-schappen enkele koppen | 2-43 |
| 125      | 40       | 180    | 4        | 50561037     | HS 556-1 Schaafkoppen                               | 2-29   | 140      | 50       | 50     | 4 V4 | 68010045     | HW        | 1586 Groef- en sponningfrenzen - Silverline      | 2-11 |
| 125      | 40       | 230    | 2+2      | 50665103     | HW 5570 Spiraal schaafkoppen                        | 2-28   | 143      | 40       | 130    | 4    | 58562689     | HS        | 520-1 Hydro-schaafkoppen                         | 2-30 |
| 125      | 40       | 240    | 2+2      | 50665104     | HW 5570 Spiraal schaafkoppen                        | 2-28   | 143      | 40       | 230    | 4    | 58562990     | HS        | 520-1 Hydro-schaafkoppen                         | 2-30 |
| 125      | 40       | 240    | 4        | 50561054     | HS 556-1 Schaafkoppen                               | 2-29   | 143      | 40       | 60     | 4    | 58562686     | HS        | 520-1 Hydro-schaafkoppen                         | 2-30 |
| 125      | 40       | 30     | 4 V4     | 68010014     | HW 1586 Groef- en sponningfrenzen - Silverline      | 2-11   | 150      | 30       | 1,5    | 12   | 50188373     | HW        | Groeffrees HW                                    | 2-4  |
| 125      | 40       | 50     | 4 V4     | 68010024     | HW 1586 Groef- en sponningfrenzen - Silverline      | 2-11   | 150      | 30       | 2,0    | 12   | 50188375     | HW        | Groeffrees HW                                    | 2-4  |
| 125      | 40       | 80     | 4        | 50561046     | HS 556-1 Schaafkoppen                               | 2-29   | 150      | 30       | 2,2    | 12   | 50188376     | HW        | Groeffrees HW                                    | 2-4  |
| 125      | 50       | 30     | 4 V4     | 68010015     | HW 1586 Groef- en sponningfrenzen - Silverline      | 2-11   | 150      | 30       | 2,5    | 12   | 50188377     | HW        | Groeffrees HW                                    | 2-4  |
| 125      | 50       | 50     | 4 V4     | 68010025     | HW 1586 Groef- en sponningfrenzen - Silverline      | 2-11   | 150      | 30       | 3,0    | 12   | 50188378     | HW        | Groeffrees HW                                    | 2-4  |
| 130      | 30       | 40     | 2        | 50664637     | HW 5567 Contraprofiel frezen                        | 2-23   | 150      | 30       | 3,5    | 12   | 50188379     | HW        | Groeffrees HW                                    | 2-4  |
| 135      | 30       | 40     | 2        | 50663047     | HW 1534-2 Verlijmprofielfrezen                      | 2-26   | 150      | 30       | 4,0    | 12   | 50188380     | HW        | Groeffrees HW                                    | 2-4  |
| 135      | 30       | 50     | 2        | 50663025     | HW 1534-2 Verlijmprofielfrezen                      | 2-26   | 150      | 30       | 4,5    | 12   | 50188381     | HW        | Groeffrees HW                                    | 2-4  |
| 135      | 30       | 60     | 2        | 50663026     | HW 1534-2 Verlijmprofielfrezen                      | 2-26   | 150      | 30       | 5,0    | 12   | 50188382     | HW        | Groeffrees HW                                    | 2-4  |
| 137      | 40       | 60     | 4        | 58562920     | 521-1 Hydro-profielmessenkoppen                     | 2-35   | 150      | 30       | 6,0    | 12   | 50188383     | HW        | Groeffrees HW                                    | 2-4  |
| 137      | 40       | 100    | 4        | 58562921     | 521-1 Hydro-profielmessenkoppen                     | 2-35   | 150      | 30       | 7,0    | 12   | 50188384     | HW        | Groeffrees HW                                    | 2-4  |
| 137      | 40       | 130    | 4        | 58562922     | 521-1 Hydro-profielmessenkoppen                     | 2-35   | 150      | 30       | 8,0    | 12   | 50188385     | HW        | Groeffrees HW                                    | 2-4  |
| 137      | 40       | 150    | 4        | 58562923     | 521-1 Hydro-profielmessenkoppen                     | 2-35   | 150      | 30       | 9,0    | 12   | 50188386     | HW        | Groeffrees HW                                    | 2-4  |
| 137      | 40       | 180    | 4        | 58562924     | 521-1 Hydro-profielmessenkoppen                     | 2-35   | 150      | 30       | 10     | 12   | 50188387     | HW        | Groeffrees HW                                    | 2-4  |
| 137      | 40       | 230    | 4        | 58562925     | 521-1 Hydro-profielmessenkoppen                     | 2-35   | 150      | 50       | 100    | 4    | 58562927     |           | 521-1 Hydro-profielmessenkoppen                  | 2-35 |
| 137      | 50       | 60     | 4        | 50822790     | 525 Rugvertande profielfrees                        | 2-33   | 150      | 50       | 100    | 6    | 58562935     |           | 521-1 Hydro-profielmessenkoppen                  | 2-35 |
| 137      | 50       | 80     | 4        | 50822791     | 525 Rugvertande profielfrees                        | 2-33   | 150      | 50       | 130    | 4    | 58562928     |           | 521-1 Hydro-profielmessenkoppen                  | 2-35 |
| 137      | 50       | 100    | 4        | 50822792     | 525 Rugvertande profielfrees                        | 2-33   | 150      | 50       | 150    | 6    | 58562936     |           | 521-1 Hydro-profielmessenkoppen                  | 2-35 |
| 137      | 50       | 130    | 4        | 50822793     | 525 Rugvertande profielfrees                        | 2-33   | 150      | 50       | 150    | 4    | 58562929     |           | 521-1 Hydro-profielmessenkoppen                  | 2-35 |
| 137      | 50       | 150    | 4        | 50822794     | 525 Rugvertande profielfrees                        | 2-33   | 150      | 50       | 180    | 4    | 58562937     |           | 521-1 Hydro-profielmessenkoppen                  | 2-35 |
| 137      | 50       | 180    | 4        | 50822795     | 525 Rugvertande profielfrees                        | 2-33   | 150      | 50       | 180    | 6    | 58562938     |           | 521-1 Hydro-profielmessenkoppen                  | 2-35 |
| 137      | 50       | 230    | 4        | 50822798     | 525 Rugvertande profielfrees                        | 2-33   | 150      | 50       | 180    | 6    | 58562939     |           | 521-1 Hydro-profielmessenkoppen                  | 2-35 |
| 140      | 30       | 13-33  | 2        | 68303301     | HW 4010 Groef- en veergereed-schappen enkele koppen | 2-43   | 150      | 50       | 230    | 4    | 58562931     |           | 521-1 Hydro-profielmessenkoppen                  | 2-35 |
| 140      | 30       | 13-33  | 2        | 68303302     | HW 4010 Groef- en veergereed-schappen enkele koppen | 2-43   | 150      | 50       | 230    | 6    | 58562939     |           | 521-1 Hydro-profielmessenkoppen                  | 2-35 |
| 140      | 30       | 13-36  | 2        | 68303304     | HW 4010 Groef- en veergereed-schappen enkele koppen | 2-43   | 150      | 50       | 260    | 4    | 58562932     |           | 521-1 Hydro-profielmessenkoppen                  | 2-35 |
| 140      | 30       | 13-36  | 2        | 68303305     | HW 4010 Groef- en veergereed-schappen enkele koppen | 2-43   | 150      | 50       | 260    | 6    | 58562940     |           | 521-1 Hydro-profielmessenkoppen                  | 2-35 |
| 140      | 30       | 13-36  | 2        | 68303306     | HW 4010 Groef- en veergereed-schappen enkele koppen | 2-43   | 150      | 50       | 310    | 4    | 58562933     |           | 521-1 Hydro-profielmessenkoppen                  | 2-35 |
| 140      | 30       | 13-36  | 2        | 68303307     | HW 4010 Groef- en veergereed-schappen enkele koppen | 2-43   | 150      | 50       | 310    | 6    | 58562941     |           | 521-1 Hydro-profielmessenkoppen                  | 2-35 |
| 140      | 30       | 13-36  | 2        | 68303308     | HW 4010 Groef- en veergereed-schappen enkele koppen | 2-43   | 150      | 50       | 60     | 4    | 58562926     |           | 521-1 Hydro-profielmessenkoppen                  | 2-35 |

## Diameter-index boorfrezes

| Ø D [mm] | Ø d [mm] | B [mm]    | Z    | Bestel-nummer | Programma  | Pagina | Ø D [mm] | Ø d [mm] | B [mm]    | Z    | Bestel-nummer | Programma  | Pagina |
|----------|----------|-----------|------|---------------|--|--------|----------|----------|-----------|------|---------------|--|--------|
| 150      | 50       | 60        | 6    | 58562934      | 521-1 Hydro-profielmessenkoppen                    | 2-35   | 180      | 40       | 13-33     | 4    | 68302401      | HW 4010 Groef- en veergereedschappen enkele koppen | 2-44   |
| 160      | 20       | 6,0       | 12   | 50660304      | HW NKP - Groeffreescirkelzaagbladen - Prisma       | 2-5    | 180      | 40       | 13-33     | 4    | 68302402      | HW 4010 Groef- en veergereedschappen enkele koppen | 2-44   |
| 160      | 30       | 4,0-7,5   | 8 V8 | 68370033      | HW 5561 Sponningmeskoppen - Silverline             | 2-9    | 180      | 40       | 13-36     | 4    | 68302404      | HW 4010 Groef- en veergereedschappen enkele koppen | 2-44   |
| 160      | 30       | 7,6       | 2    | 68370083      | HW 5561 Groeffrezen                                | 2-9    | 180      | 40       | 13-36     | 4    | 68302405      | HW 4010 Groef- en veergereedschappen enkele koppen | 2-44   |
| 160      | 30       | 8,0-15,5  | 4 V4 | 68380023      | HW 5561 Groeffrezen Silverline                     | 2-10   | 180      | 40       | 13-36     | 4    | 68302406      | HW 4010 Groef- en veergereedschappen enkele koppen | 2-44   |
| 160      | 30       | 12,5-24,0 | 4 V4 | 68390023      | HW 5562 Groeffrezen Silverline                     | 2-10   | 180      | 40       | 13-36     | 4    | 68302407      | HW 4010 Groef- en veergereedschappen enkele koppen | 2-44   |
| 160      | 30       | 15,0-30,0 | 4 V4 | 68400063      | HW 5562 Groeffrezen                                | 2-10   | 180      | 40       | 13-36     | 4    | 68302408      | HW 4010 Groef- en veergereedschappen enkele koppen | 2-44   |
| 160      | 30       | 37-48     | 2    | 50664655      | HW 5554 Contraprofielgarnituur                     | 2-24   | 180      | 40       | 13-40     | 4    | 68302403      | HW 4010 Groef- en veergereedschappen enkele koppen | 2-44   |
| 160      | 40       | 4,0-7,5   | 8 V8 | 68370034      | HW 5561 Groeffrezen                                | 2-9    | 180      | 40       | 35        | 6    | 58532354      | HS 4000 Groef- en veergereedschappen               | 2-41   |
| 160      | 40       | 7,6       | 2    | 68370084      | HW 5561 Groeffrezen Silverline                     | 2-9    | 180      | 40       | 35        | 6    | 58532358      | HS 4000 Groef- en veergereedschappen               | 2-41   |
| 160      | 40       | 8,0-15,5  | 4 V4 | 68380024      | HW 5562 Groeffrezen Silverline                     | 2-10   | 180      | 40       | 35        | 6    | 58532382      | HS 4000 Groef- en veergereedschappen               | 2-41   |
| 160      | 40       | 12,5-24,0 | 4 V4 | 68390024      | HW 5562 Groeffrezen Silverline                     | 2-10   | 180      | 40       | 35        | 6    | 58532384      | HS 4000 Groef- en veergereedschappen               | 2-41   |
| 160      | 40       | 15,0-30,0 | 4 V4 | 68400064      | HW 5562 Groeffrezen                                | 2-10   | 180      | 40       | 35        | 6    | 58532387      | HS 4000 Groef- en veergereedschappen               | 2-41   |
| 163      | 50       | 100       | 4    | 58562691      | HS 520-1 Hydro-schaafkoppen                        | 2-30   | 180      | 40       | 35        | 6    | 58532387      | HS 4000 Groef- en veergereedschappen               | 2-41   |
| 163      | 50       | 100       | 6    | 58562692      | HS 520-1 Hydro-schaafkoppen                        | 2-30   | 180      | 40       | 35        | 6+3  | 58532361      | HS 4000 Groef- en veergereedschappen               | 2-41   |
| 163      | 50       | 100       | 8    | 58562740      | HS 520-1 Hydro-schaafkoppen                        | 2-30   | 180      | 40       | 35        | 6+3  | 58532390      | HS 4000 Groef- en veergereedschappen               | 2-41   |
| 163      | 50       | 100       | 8    | 58562943      | 521-1 Hydro-profielmessenkoppen                    | 2-35   | 180      | 40       | 35        | 6+3  | 58532391      | HS 4000 Groef- en veergereedschappen               | 2-41   |
| 163      | 50       | 130       | 4    | 58562693      | HS 520-1 Hydro-schaafkoppen                        | 2-30   | 180      | 50       | 13-33     | 4    | 68302501      | HW 4010 Groef- en veergereedschappen enkele koppen | 2-44   |
| 163      | 50       | 130       | 4    | 58562741      | HS 520-1 Hydro-schaafkoppen                        | 2-30   | 180      | 50       | 13-33     | 4    | 68302502      | HW 4010 Groef- en veergereedschappen enkele koppen | 2-44   |
| 163      | 50       | 130       | 6    | 58562742      | HS 520-1 Hydro-schaafkoppen                        | 2-30   | 180      | 50       | 13-36     | 4    | 68302504      | HW 4010 Groef- en veergereedschappen enkele koppen | 2-44   |
| 163      | 50       | 130       | 8    | 58562739      | HS 520-1 Hydro-schaafkoppen                        | 2-30   | 180      | 50       | 13-36     | 4    | 68302505      | HW 4010 Groef- en veergereedschappen enkele koppen | 2-44   |
| 163      | 50       | 130       | 8    | 58562944      | 521-1 Hydro-profielmessenkoppen                    | 2-35   | 180      | 50       | 13-36     | 4    | 68302506      | HW 4010 Groef- en veergereedschappen enkele koppen | 2-44   |
| 163      | 50       | 150       | 6    | 58562694      | HS 520-1 Hydro-schaafkoppen                        | 2-30   | 180      | 50       | 13-36     | 4    | 68302507      | HW 4010 Groef- en veergereedschappen enkele koppen | 2-44   |
| 163      | 50       | 150       | 8    | 58562743      | HS 520-1 Hydro-schaafkoppen                        | 2-30   | 180      | 50       | 13-36     | 4    | 68302508      | HW 4010 Groef- en veergereedschappen enkele koppen | 2-44   |
| 163      | 50       | 150       | 8    | 58562945      | 521-1 Hydro-profielmessenkoppen                    | 2-35   | 180      | 50       | 13-40     | 4    | 68302503      | HW 4010 Groef- en veergereedschappen enkele koppen | 2-44   |
| 163      | 50       | 180       | 4    | 58562700      | HS 520-1 Hydro-schaafkoppen                        | 2-30   | 200      | 30       |           | 2+2  | 68255130      | HW 5540 Bossingfrezen - Silverline                 | 2-20   |
| 163      | 50       | 180       | 6    | 58562702      | HS 520-1 Hydro-schaafkoppen                        | 2-30   | 200      | 30       |           | 2+2  | 68255230      | HW 5540 Bossingfrezen - Silverline                 | 2-20   |
| 163      | 50       | 180       | 8    | 58562750      | HS 520-1 Hydro-schaafkoppen                        | 2-30   | 200      | 30       | 4,0-7,5   | 8 V8 | 68370053      | HW 5561 Sponningmeskoppen - Silverline             | 2-9    |
| 163      | 50       | 180       | 8    | 58562946      | 521-1 Hydro-profielmessenkoppen                    | 2-35   | 200      | 30       | 7,6       | 2    | 68370103      | HW 5561 Groeffrezen                                | 2-9    |
| 163      | 50       | 230       | 4    | 58562695      | HS 520-1 Hydro-schaafkoppen                        | 2-30   | 200      | 30       | 8,0-15,5  | 4 V4 | 68380033      | HW 5562 Groeffrezen                                | 2-10   |
| 163      | 50       | 230       | 6    | 58562696      | HS 520-1 Hydro-schaafkoppen                        | 2-30   | 200      | 30       | 12,0      | 2    | 68390073      | HW 5562 Groeffrezen - Silverline                   | 2-10   |
| 163      | 50       | 230       | 8    | 58562744      | HS 520-1 Hydro-schaafkoppen                        | 2-30   | 200      | 30       | 12,5-24,0 | 4 V4 | 68390033      | HW 5562 Groeffrezen Silverline                     | 2-10   |
| 163      | 50       | 230       | 8    | 58562947      | 521-1 Hydro-profielmessenkoppen                    | 2-35   | 200      | 30       | 15,0      | 2    | 68380083      | HW 5562 Groeffrezen - Silverline                   | 2-10   |
| 163      | 50       | 260       | 4    | 58562697      | HS 520-1 Hydro-schaafkoppen                        | 2-30   | 200      | 30       | 15,0-30,0 | 4 V4 | 68400033      | HW 5562 Groeffrezen                                | 2-10   |
| 163      | 50       | 260       | 6    | 58562698      | HS 520-1 Hydro-schaafkoppen                        | 2-30   | 200      | 40       | 4,0-7,5   | 8 V8 | 68370054      | HW 5561 Groeffrezen                                | 2-9    |
| 163      | 50       | 260       | 8    | 58562745      | HS 520-1 Hydro-schaafkoppen                        | 2-30   | 200      | 40       | 7,6       | 2    | 68370104      | HW 5561 Groeffrezen                                | 2-9    |
| 163      | 50       | 260       | 8    | 58562948      | 521-1 Hydro-profielmessenkoppen                    | 2-35   | 200      | 40       | 8,0-15,5  | 4 V4 | 68380034      | HW 5562 Groeffrezen                                | 2-10   |
| 163      | 50       | 310       | 4    | 58562701      | HS 520-1 Hydro-schaafkoppen                        | 2-30   | 200      | 40       |           | 2+2  | 68255140      | HW 5540 Bossingfrezen - Silverline                 | 2-20   |
| 163      | 50       | 310       | 6    | 58562703      | HS 520-1 Hydro-schaafkoppen                        | 2-30   | 200      | 40       |           | 2+2  | 68255240      | HW 5540 Bossingfrezen - Silverline                 | 2-20   |
| 163      | 50       | 310       | 8    | 58562751      | HS 520-1 Hydro-schaafkoppen                        | 2-30   | 200      | 40       | 12,0      | 2    | 68390074      | HW 5562 Groeffrezen - Silverline                   | 2-10   |
| 163      | 50       | 310       | 8    | 58562949      | 521-1 Hydro-profielmessenkoppen                    | 2-35   | 200      | 40       | 12,5-24,0 | 4 V4 | 68390034      | HW 5562 Groeffrezen                                | 2-10   |
| 163      | 50       | 60        | 4    | 58562687      | HS 520-1 Hydro-schaafkoppen                        | 2-30   | 200      | 40       | 15,0      | 2    | 68380084      | HW 5562 Groeffrezen - Silverline                   | 2-10   |
| 163      | 50       | 60        | 6    | 58562688      | HS 520-1 Hydro-schaafkoppen                        | 2-30   | 200      | 40       | 15,0-30,0 | 4 V4 | 68400034      | HW 5562 Sponningmeskoppen - Silverline             | 2-10   |
| 163      | 50       | 60        | 8    | 58562738      | HS 520-1 Hydro-schaafkoppen                        | 2-30   | 200      | 50       | 4,0-7,5   | 8 V8 | 68370055      | HW 5561 Groeffrezen Silverline                     | 2-9    |
| 163      | 50       | 60        | 8    | 58562942      | 521-1 Hydro-profielmessenkoppen                    | 2-35   | 200      | 50       | 7,6       | 2    | 68370105      | HW 5561 Groeffrezen Silverline                     | 2-9    |
| 167      | 30       | 50        | 2    | 50663009      | HW 1580 Zwenkfrezen                                | 2-17   | 200      | 50       | 8,0-15,5  | 4 V4 | 68380035      | HW 5562 Groeffrezen                                | 2-10   |
| 174      | 30       | 26        | 2+2  | 50664636      | HW 5556 Verstek-verlijmfrezen                      | 2-25   | 200      | 40       |           | 2+2  | 68255150      | HW 5540 Bossingfrezen - Silverline                 | 2-20   |
| 180      | 30       | 4,0       | 18   | 50169685      | HW Groeffrees HM                                   | 2-5    | 200      | 40       |           | 2+2  | 68255250      | HW 5540 Bossingfrezen - Silverline                 | 2-20   |
| 180      | 30       | 5,0       | 18   | 50169684      | HW Groeffrees HM                                   | 2-5    | 200      | 40       | 12,0      | 2    | 68390074      | HW 5562 Groeffrezen - Silverline                   | 2-10   |
| 180      | 30       | 8,0       | 18   | 50169683      | HW Groeffrees HM                                   | 2-5    | 200      | 40       | 12,5-24,0 | 4 V4 | 68390034      | HW 5562 Groeffrezen                                | 2-10   |
| 180      | 30       | 10        | 18   | 50169682      | HW Groeffrees HM                                   | 2-5    | 200      | 40       | 15,0      | 2    | 68380084      | HW 5562 Groeffrezen - Silverline                   | 2-10   |
| 180      | 30       | 13-33     | 4    | 68302301      | HW 4010 Groef- en veergereedschappen enkele koppen | 2-44   | 200      | 40       | 15,0-30,0 | 4 V4 | 68400034      | HW 5562 Sponningmeskoppen - Silverline             | 2-10   |
| 180      | 30       | 13-33     | 4    | 68302302      | HW 4010 Groef- en veergereedschappen enkele koppen | 2-44   | 200      | 50       | 4,0-7,5   | 8 V8 | 68370055      | HW 5561 Groeffrezen Silverline                     | 2-9    |
| 180      | 30       | 13-36     | 4    | 68302304      | HW 4010 Groef- en veergereedschappen enkele koppen | 2-44   | 200      | 50       | 7,6       | 2    | 68370105      | HW 5561 Groeffrezen Silverline                     | 2-9    |
| 180      | 30       | 13-36     | 4    | 68302305      | HW 4010 Groef- en veergereedschappen enkele koppen | 2-44   | 200      | 50       | 8,0-15,5  | 4 V4 | 68380035      | HW 5562 Groeffrezen                                | 2-10   |
| 180      | 30       | 13-36     | 4    | 68302306      | HW 4010 Groef- en veergereedschappen enkele koppen | 2-44   | 200      | 50       |           | 2+2  | 68255150      | HW 5540 Bossingfrezen - Silverline                 | 2-20   |
| 180      | 30       | 13-36     | 4    | 68302307      | HW 4010 Groef- en veergereedschappen enkele koppen | 2-44   | 200      | 50       |           | 2+2  | 68255250      | HW 5540 Bossingfrezen - Silverline                 | 2-20   |
| 180      | 30       | 13-36     | 4    | 68302308      | HW 4010 Groef- en veergereedschappen enkele koppen | 2-44   | 200      | 50       | 12,0      | 2    | 68390075      | HW 5562 Groeffrezen - Silverline                   | 2-10   |
| 180      | 30       | 13-40     | 4    | 68302303      | HW 4010 Groef- en veergereedschappen enkele koppen | 2-44   | 200      | 50       | 12,5-24,0 | 4 V4 | 68390035      | HW 5562 Groeffrezen                                | 2-10   |

## Diameter-index boorfrees

| Ø D<br>[mm] | Ø d<br>[mm] | B<br>[mm]     | Z    | Bestel-<br>nummer |    | Programma                     | Pagina |
|-------------|-------------|---------------|------|-------------------|----|-------------------------------|--------|
| 200         | 50          | 15,0          | 2    | 68380085          | HW | 5562 Groeffrezen - Silverline | 2-10   |
| 200         | 50          | 15,0-<br>30,0 | 4 V4 | 68400035          | HW | 5562 Groeffrezen Silverline   | 2-10   |
| 203         | 50          | 100           | 12   | 58562752          | HS | 520-1 Hydro-schaafkoppen      | 2-30   |
| 203         | 50          | 150           | 12   | 58562753          | HS | 520-1 Hydro-schaafkoppen      | 2-30   |
| 203         | 50          | 230           | 12   | 58562754          | HS | 520-1 Hydro-schaafkoppen      | 2-30   |
| 203         | 50          | 260           | 12   | 58562755          | HS | 520-1 Hydro-schaafkoppen      | 2-30   |
| 203         | 50          | 310           | 12   | 58562756          | HS | 520-1 Hydro-schaafkoppen      | 2-30   |
| 203         | 50          | 330           | 12   | 58562757          | HS | 520-1 Hydro-schaafkoppen      | 2-30   |
| 250         | 30          | 8,0-<br>15,0  | 8 V8 | 68380043          | HW | 5562 Groeffrezen - Silverline | 2-10   |
| 250         | 40          | 8,0-<br>15,0  | 8 V8 | 68380044          | HW | 5562 Groeffrezen - Silverline | 2-10   |
| 250         | 50          | 8,0-<br>15,0  | 8 V8 | 68380045          | HW | 5562 Groeffrezen - Silverline | 2-10   |

# Diameter-index schachtfrees

| Ø D<br>[mm] | Ø d<br>[mm] | L2<br>[mm] | Z   | Bestel-<br>nummer | Programma  | Pagina | Ø D<br>[mm] | Ø d<br>[mm] | L2<br>[mm] | Z       | Bestel-<br>nummer | Programma  | Pagina |
|-------------|-------------|------------|-----|-------------------|--|--------|-------------|-------------|------------|---------|-------------------|--|--------|
| 4.0         | 4.0         | 15         | 2   | 50811418          | VHW 2257 Afwerkfrees                                       | 3-8    | 16          | 16          | 28         | 3+3     | 50811803          | DP 3506 High performance schachtfrees CM           | 3-21   |
| 6.0         | 6.0         | 15         | 2   | 50811419          | VHW 2257-1 Afwerkfrees                                     | 3-9    | 16          | 16          | 28         | 3+3     | 58186574          | DP 3506 High performance schachtfrees CM           | 3-21   |
| 6.0         | 6.0         | 15         | 2   | 50811420          | VHW 2257 Afwerkfrees                                       | 3-8    | 16          | 16          | 30         | 1+1     | 50811903          | HW 2235 Schachtfrees                               | 3-3    |
| 6.0         | 12          | 12         | 1   | 50811684          | DP 3501 Schachtfrees                                       | 3-13   | 16          | 16          | 32         | 4 (2+2) | 58811950          | 3514 Schrob-afwerkfrees                            | 3-16   |
| 8.0         | 8.0         | 30         | 2   | 50811034          | VHW 2257-1 Afwerkfrees                                     | 3-9    | 16          | 16          | 35         | 1       | 50811136          | DP 3501 Schachtfrees                               | 3-13   |
| 8.0         | 8.0         | 30         | 2   | 50811421          | VHW 2257 Afwerkfrees                                       | 3-8    | 16          | 16          | 35         | 1+1     | 58186796          | DP 3502 Bovenfrees                                 | 3-14   |
| 8.0         | 8.0         | 32         | 2+2 | 50811564          | VHW 2257-2 Afwerkfrees                                     | 3-10   | 16          | 16          | 35         | 1+1     | 58186797          | DP 3502 Bovenfrees                                 | 3-14   |
| 8.0         | 12          | 12         | 1   | 50811128          | DP 3501 Schachtfrees                                       | 3-13   | 16          | 16          | 35         | 2       | 50811040          | VHW 2257-1 Afwerkfrees                             | 3-9    |
| 8.0         | 12          | 20         | 1   | 50811001          | HW 2231 Schachtfrees                                       | 3-1    | 16          | 16          | 35         | 2       | 50811407          | VHW 2265-1 Schrobfrees                             | 3-7    |
| 9.8         | 12          | 23         | 2   | 58186879          | 3519 Profiel-groef-bovenfrees VHW - voor Lamello Clamex P® | 3-37   | 16          | 16          | 35         | 2       | 50811428          | VHW 2257 Afwerkfrees                               | 3-8    |
| 10          | 10          | 20         | 1   | 50811810          | 3512 Profiel-gleuf-bovenfrees HW - voor Lamello Clamex P®  | 3-37   | 16          | 16          | 35         | 3       | 50811028          | VHW 2265-1 Schrobfrees                             | 3-7    |
| 10          | 10          | 25         | 1   | 50811900          | HW 2231 Schachtfrees                                       | 3-1    | 16          | 16          | 35         | 3       | 50811029          | VHW 2265 Schrobfrees                               | 3-6    |
| 10          | 10          | 30         | 2   | 50811036          | VHW 2257-1 Afwerkfrees                                     | 3-9    | 16          | 16          | 35         | 3       | 50811429          | VHW 2257 Afwerkfrees                               | 3-8    |
| 10          | 10          | 30         | 2   | 50811401          | VHW 2265-1 Schrobfrees                                     | 3-7    | 16          | 16          | 38         | 2+2     | 50186148          | 3503 Highperformance bovenfrees DP - Z=2+2         | 3-17   |
| 10          | 10          | 30         | 2   | 50811402          | VHW 2265 Schrobfrees                                       | 3-6    | 16          | 16          | 38         | 2+2     | 50186149          | 3503 Highperformance bovenfrees DP - Z=2+2         | 3-17   |
| 10          | 10          | 30         | 2   | 50811422          | VHW 2257 Afwerkfrees                                       | 3-8    | 16          | 16          | 50         | 1+1     | 50811904          | HW 2236 Schachtfrees                               | 3-4    |
| 10          | 10          | 32         | 2+2 | 50811565          | VHW 2257-2 Afwerkfrees                                     | 3-10   | 16          | 16          | 52         | 2       | 50811071          | VHW 2269 Ventilatie Afwerkfrees                    | 3-11   |
| 10          | 12          | 20         | 1   | 58185703          | 3518 Profiel-groeffrees DP - voor Lamello Clamex P®        | 3-38   | 16          | 16          | 55         | 2       | 50811041          | VHW 2257-1 Afwerkfrees                             | 3-9    |
| 10          | 12          | 22         | 1+1 | 58186789          | DP 3502 Bovenfrees   | 3-14   | 16          | 16          | 55         | 2       | 50811410          | VHW 2265-1 Schrobfrees                             | 3-7    |
| 10          | 12          | 22         | 2   | 50811130          | DP 3501 Schachtfrees                                       | 3-13   | 16          | 16          | 55         | 2+2     | 50811567          | VHW 2257-2 Afwerkfrees                             | 3-10   |
| 10          | 12          | 22         | 2   | 50811930          | DP 3501 Schachtfrees                                       | 3-13   | 16          | 16          | 55         | 3       | 50811408          | VHW 2265-1 Schrobfrees                             | 3-7    |
| 10          | 12          | 25         | 1   | 50811002          | HW 2231 Schachtfrees                                       | 3-1    | 16          | 16          | 55         | 3       | 50811409          | VHW 2265 Schrobfrees                               | 3-6    |
| 12          | 12          | 22         | 1+1 | 58186790          | DP 3502 Bovenfrees   | 3-14   | 16          | 16          | 55         | 3       | 50811432          | VHW 2257-1 Afwerkfrees                             | 3-9    |
| 12          | 12          | 25.4       | 1   | 50811132          | DP 3501 Schachtfrees                                       | 3-13   | 16          | 16          | 55         | 3       | 50811434          | VHW 2257-1 Afwerkfrees                             | 3-9    |
| 12          | 12          | 28         | 1+1 | 58186792          | DP 3502 Bovenfrees   | 3-14   | 16          | 16          | 55         | 3       | 50811435          | VHW 2257 Afwerkfrees                               | 3-8    |
| 12          | 12          | 28         | 1+1 | 58186793          | DP 3502 Bovenfrees   | 3-14   | 16          | 16          | 75         | 2       | 50811731          | VHW 2268 Ventilatie Schrobfrees                    | 3-11   |
| 12          | 12          | 30         | 1   | 50811003          | HW 2231 Schachtfrees                                       | 3-1    | 16          | 25          | 50         | 1+1     | 50811905          | HW 2236 Schachtfrees                               | 3-4    |
| 12          | 12          | 42         | 2   | 50811037          | VHW 2257-1 Afwerkfrees                                     | 3-9    | 17          | 10          | 8.3        | 1       | 50811713          | HW 1591 Siergroeffrees                             | 3-30   |
| 12          | 12          | 42         | 2   | 50811423          | VHW 2257 Afwerkfrees                                       | 3-8    | 17          | 10          | 8.3        | 1       | 58186880          | HW 1591 Siergroeffrees                             | 3-30   |
| 12          | 12          | 42         | 2+2 | 50811566          | VHW 2257-2 Afwerkfrees                                     | 3-10   | 18          | 16          | 28         | 1+1     | 58186798          | DP 3502 Bovenfrees                                 | 3-14   |
| 12          | 12          | 42         | 3   | 50811404          | VHW 2265 Schrobfrees                                       | 3-6    | 18          | 16          | 35         | 1+1     | 58186801          | DP 3502 Bovenfrees                                 | 3-14   |
| 12          | 12          | 42         | 3   | 50811424          | VHW 2257-1 Afwerkfrees                                     | 3-9    | 18          | 16          | 35         | 1+1     | 58186802          | DP 3502 Bovenfrees                                 | 3-14   |
| 12          | 12          | 42         | 3   | 50811425          | VHW 2257 Afwerkfrees                                       | 3-8    | 18          | 16          | 43         | 1+1     | 58186805          | DP 3502 Bovenfrees                                 | 3-14   |
| 12          | 12          | 45         | 2   | 50811403          | VHW 2265-1 Schrobfrees                                     | 3-7    | 18          | 16          | 43         | 1+1     | 58186806          | DP 3502 Bovenfrees                                 | 3-14   |
| 12          | 12          | 45         | 3   | 50811025          | VHW 2265-1 Schrobfrees                                     | 3-7    | 18          | 18          | 55         | 3       | 50811030          | VHW 2265-1 Schrobfrees                             | 3-7    |
| 12          | 12          | 47         | 2   | 50811449          | VHW 2269 Ventilatie Afwerkfrees                            | 3-11   | 18          | 18          | 55         | 3       | 50811436          | VHW 2257-1 Afwerkfrees                             | 3-9    |
| 12          | 12          | 70         | 2   | 50811450          | VHW 2269 Ventilatie Afwerkfrees                            | 3-11   | 18          | 20          | 115        | 3       | 50811927          | VHW 2254 Slotkasten-Schrobfrees                    | 3-12   |
| 12          | 12,7        | 25.4       | 1+1 | 58186791          | DP 3502 Bovenfrees   | 3-14   | 18          | 20          | 19         | 1+1     | 58185614          | DP 3620 p-systeem highperformance-groef-bovenfrees | 3-25   |
| 12          | 16          | 21         | 3   | 58811842          | 3509 Highperformance-bovenfrees VHW DP - Z=3               | 3-18   | 18          | 20          | 28         | 1+1     | 58186799          | DP 3502 Bovenfrees                                 | 3-14   |
| 12          | 16          | 22         | 2+2 | 58186112          | DP 3506 High performance schachtfrees CM                   | 3-20   | 18          | 20          | 28         | 1+1     | 58186800          | DP 3502 Bovenfrees                                 | 3-14   |
| 12          | 16          | 22         | 2+2 | 58186113          | DP 3506 High performance schachtfrees CM                   | 3-20   | 18          | 20          | 35         | 1+1     | 58186803          | DP 3502 Bovenfrees                                 | 3-14   |
| 12          | 16          | 22         | 3+3 | 58186571          | DP 3506 High performance schachtfrees CM                   | 3-21   | 18          | 20          | 35         | 1+1     | 58186804          | DP 3502 Bovenfrees                                 | 3-14   |
| 12          | 16          | 23         | 3+3 | 58185518          | DP 3506 High performance schachtfrees CM                   | 3-21   | 18          | 20          | 43         | 1+1     | 58186807          | DP 3502 Bovenfrees                                 | 3-14   |
| 12          | 16          | 28         | 3   | 50811804          | 3509 Highperformance-bovenfrees VHW DP - Z=3               | 3-18   | 18          | 20          | 43         | 1+1     | 58186808          | DP 3502 Bovenfrees                                 | 3-14   |
| 12          | 16          | 28         | 3+3 | 58186572          | DP 3506 High performance schachtfrees CM                   | 3-21   | 18          | 20          | 7.0        | 1+1     | 50184772          | DP 3620 p-systeem highperformance-groef-bovenfrees | 3-25   |
| 12          | 16          | 30         | 3   | 50811805          | 3509 Highperformance-bovenfrees VHW DP - Z=3               | 3-18   | 18          | 25          | 28         | 3+3     | 58186118          | DP 3505 High performance schachtfrees              | 3-19   |
| 14          | 12          | 12.5       | 3   | 50811813          | HW 1593 V-groef-schrift-frees Z=3                          | 3-34   | 18          | 25          | 50         | 1+1     | 50811906          | HW 2236 Schachtfrees                               | 3-4    |
| 14          | 12          | 16.5       | 3   | 50811812          | HW 1593 V-groef-en schrift-frees Z=3                       | 3-34   | 18          | 25          | 50         | 1+1     | 50811907          | HW 2236 Schachtfrees                               | 3-4    |
| 14          | 14          | 35         | 3   | 50811026          | VHW 2265-1 Schrobfrees                                     | 3-7    | 18          | 25          | 55         | 2       | 50811908          | HW 2237 Schachtfrees                               | 3-5    |
| 14          | 14          | 35         | 3   | 50811426          | VHW 2257-1 Afwerkfrees                                     | 3-9    | 18          | 25          | 55         | 2       | 50811909          | HW 2237 Schachtfrees                               | 3-5    |
| 14          | 14          | 47         | 2   | 50811070          | VHW 2269 Ventilatie Afwerkfrees                            | 3-11   | 19          | 12          | 14.5       | 2       | 50811815          | HW 1520 Frees met verdiepte handgreep Z=2          | 3-34   |
| 14          | 14          | 55         | 3   | 50811027          | VHW 2265-1 Schrobfrees                                     | 3-7    | 20          | 20          | 28         | 2+2     | 50186150          | 3503 Highperformance bovenfrees DP - Z=2+2         | 3-17   |
| 14          | 14          | 55         | 3   | 50811427          | VHW 2257-1 Afwerkfrees                                     | 3-9    | 20          | 20          | 35         | 1+1     | 58186809          | DP 3502 Bovenfrees                                 | 3-14   |
| 14          | 14          | 95         | 2   | 50811928          | VHW 2255 Slotkasten-Afwerkfrees                            | 3-12   | 20          | 20          | 38         | 2+2     | 50186153          | 3503 Highperformance bovenfrees DP - Z=2+2         | 3-17   |
| 14          | 16          | 20         | 2+1 | 50811809          | 3511 Highperformance Schrobfrees DP                        | 3-15   | 20          | 20          | 38         | 3+3     | 58186119          | DP 3505 High performance schachtfrees              | 3-19   |
| 14          | 16          | 33         | 3+3 | 58185799          | DP 3506 High performance schachtfrees CM                   | 3-21   | 20          | 20          | 48         | 2+2     | 50186156          | 3503 Highperformance bovenfrees DP - Z=2+2         | 3-17   |
| 16          | 16          | 115        | 2   | 50811929          | VHW 2255 Slotkasten-Afwerkfrees                            | 3-12   | 20          | 20          | 50         | 2+2     | 50811808          | 3510 Schrobfrees DP                                | 3-15   |
| 16          | 16          | 115        | 3   | 50811926          | VHW 2254 Slotkasten-Schrobfrees                            | 3-12   | 20          | 20          | 55         | 2       | 50811413          | VHW 2265-1 Schrobfrees                             | 3-7    |
| 16          | 16          | 22         | 1+1 | 58186794          | DP 3502 Bovenfrees   | 3-14   | 20          | 20          | 55         | 3       | 50811031          | VHW 2265-1 Schrobfrees                             | 3-7    |
| 16          | 16          | 22         | 3+3 | 58186573          | DP 3506 High performance schachtfrees CM                   | 3-21   | 20          | 20          | 55         | 3       | 50811414          | VHW 2265 Schrobfrees                               | 3-6    |
| 16          | 16          | 25.4       | 1   | 50811134          | DP 3501 Schachtfrees                                       | 3-13   | 20          | 20          | 55         | 3       | 50811437          | VHW 2257-1 Afwerkfrees                             | 3-9    |
| 16          | 16          | 28         | 1+1 | 58186795          | DP 3502 Bovenfrees   | 3-14   | 20          | 20          | 55         | 3       | 50811438          | VHW 2257 Afwerkfrees                               | 3-8    |
| 16          | 16          | 28         | 2+2 | 50186147          | 3503 Highperformance bovenfrees DP - Z=2+2                 | 3-17   | 20          | 20          | 75         | 3       | 50811032          | VHW 2265-1 Schrobfrees                             | 3-7    |
| 16          | 16          | 28         | 2+2 | 58186114          | DP 3506 High performance schachtfrees CM                   | 3-20   | 20          | 20          | 75         | 3       | 50811439          | VHW 2257-1 Afwerkfrees                             | 3-9    |
|             |             |            |     |                   |  |        | 20          | 20          | 75         | 3       | 50811562          | VHW 2257 Afwerkfrees                               | 3-8    |
|             |             |            |     |                   |  |        | 20          | 25          | 28         | 2+2     | 50186151          | 3503 Highperformance bovenfrees DP - Z=2+2         | 3-17   |
|             |             |            |     |                   |  |        | 20          | 25          | 28         | 2+2     | 50186152          | 3503 Highperformance bovenfrees DP - Z=2+2         | 3-17   |

## Diameter-index schachtfrees

| Ø D [mm] | Ø d [mm] | L2 [mm] | Z     | Bestelnummer | Programma   | Pagina |
|----------|----------|---------|-------|--------------|---|--------|
| 20       | 25       | 29,5    | 1+1   | 50184380     | DP 3600 p-systeem highperformance bovenfrees      | 3-23   |
| 20       | 25       | 38      | 2+2   | 50186154     | 3503 Highperformance bovenfrees DP - Z=2+2        | 3-17   |
| 20       | 25       | 38      | 2+2   | 50186155     | 3503 Highperformance bovenfrees DP - Z=2+2        | 3-17   |
| 20       | 25       | 48      | 2+2   | 50186157     | 3503 Highperformance bovenfrees DP - Z=2+2        | 3-17   |
| 20       | 25       | 48      | 2+2   | 50186158     | 3503 Highperformance bovenfrees DP - Z=2+2        | 3-17   |
| 20       | 25       | 52      | 1+1   | 58186810     | DP 3502 Bovenfrees                                | 3-14   |
| 20       | 25       | 52      | 1+1   | 58186811     | DP 3502 Bovenfrees                                | 3-14   |
| 20       | 25       | 53      | 2+2   | 50811901     | HW 2233 Schachtfrees                              | 3-2    |
| 20       | 25       | 53      | 2+2   | 50811902     | HW 2233 Schachtfrees                              | 3-2    |
| 20       | 25       | 55      | 2     | 50811910     | HW 2237 Schachtfrees                              | 3-5    |
| 25       | 25       | 28      | 3+3   | 58186120     | DP 3505 High performance schachtfrees             | 3-19   |
| 25       | 25       | 28      | 3+3   | 58186121     | DP 3505 High performance schachtfrees             | 3-19   |
| 25       | 25       | 38      | 3+3   | 58186122     | DP 3505 High performance schachtfrees             | 3-19   |
| 25       | 25       | 48      | 2+2   | 50184384     | DP 3600 p-systeem highperformance bovenfrees      | 3-23   |
| 25       | 25       | 48      | 3+3   | 58186124     | DP 3505 High performance schachtfrees             | 3-19   |
| 25       | 25       | 48      | 3+3   | 58186125     | DP 3505 High performance schachtfrees             | 3-19   |
| 25       | 25       | 65      | 2+2   | 50186159     | 3503 Highperformance bovenfrees DP - Z=2+2        | 3-17   |
| 25       | 25       | 65      | 2+2   | 50186160     | 3503 Highperformance bovenfrees DP - Z=2+2        | 3-17   |
| 28       | 12       | 26      | 2     | 50811817     | HW 1521 Braam-meskop - afschuiningshoek 15°       | 3-33   |
| 38       | 12       | 18      | 2     | 50811816     | HW 1520 Frees met verdiepte handgreep Z=2         | 3-34   |
| 40       | 16       | 6       | 2     | 50811820     | HW 1523 Afrond-afschuinings-meskoppen set 1       | 3-35   |
| 41.5     | 25       | 41,3    | 1     | 50811807     | 5573 Folding-afschuiningsmeskop HW - Z1           | 3-32   |
| 48       | 25       | 22      | 4+2+4 | 58186140     | DP 3507 Highperformance kantenfrees DP - Z=4+2+4  | 3-22   |
| 48       | 25       | 28      | 4+2+4 | 58186142     | DP 3507 Highperformance kantenfrees               | 3-22   |
| 48       | 25       | 35      | 4+2+4 | 58186144     | DP 3507 Highperformance kantenfrees               | 3-22   |
| 48       | 25       | 48      | 4+2+4 | 58186145     | DP 3507 Highperformance kantenfrees               | 3-22   |
| 48       | 25       | 48      | 4+2+4 | 58186146     | DP 3507 Highperformance kantenfrees               | 3-22   |
| 52       | 12       | 7       | 6     | 50811814     | HW 1594 Vlakfrees Z=6                             | 3-26   |
| 60       | 20       | 9       | 2     | 50811821     | HW 1523 Abrond-afschuiningsmeskoppen Set 2        | 3-35   |
| 60       | 25       | 38      | 3+3   | 50184083     | DP 3610 p-systeem highperformance-voeg-bovenfrees | 3-24   |
| 74       | 25       | 28      | 2     | 50811819     | HW 1522 afschuiningsmeskoppen Z=2                 | 3-33   |
| 90       | 20       | 76      | 2+2   | 50811832     | HW 1524 Handloop-meskoppen Z=2+2                  | 3-36   |
| 90       | 20       | 76      | 2+2   | 50811833     | HW 1524 Handloop-meskoppen Z=2+2                  | 3-36   |
| 90       | 20       | 76      | 2+2   | 50811834     | HW 1524 Handloop-meskoppen Z=2+2                  | 3-36   |
| 100      | 25       | 5,6     | 8     | 50811708     | DP 3508 Vlak- en sponning-schachtfrees            | 3-26   |
| 100      | 25       | 14      | 4     | 50811806     | 5572 Vlak- en fels-bovenfreeskop HW               | 3-27   |
| 100      | 25       | 40      | 2     | 50811714     | HW 1581 Zwenkfrees                                | 3-31   |



# Diameter-index boor

| Ø D<br>[mm] | Ø d<br>[mm] | L2<br>[mm] | L1<br>[mm] | Bestel-<br>nummer | Programma                        | Pagina | Ø D<br>[mm] | Ø d<br>[mm] | L2<br>[mm] | L1<br>[mm] | Bestel-<br>nummer       | Programma                        | Pagina |
|-------------|-------------|------------|------------|-------------------|----------------------------------|--------|-------------|-------------|------------|------------|-------------------------|----------------------------------|--------|
| 2.0         | 2.0         | 25         | 50         | 50600740          | VHW 2010 Spiraalboor             | 4-1    | 6.0         | 10          | 36         | 70         | 50600693                | VHW 2042 hoogwaardige deugelboor | 4-10   |
| 2.0         | 2.0         | 25         | 50         | 50600741          | VHW 2010 Spiraalboor             | 4-1    | 7.0         | 10          | 35         | 70         | 50600120                | HW 2032 Drevvelboren             | 4-6    |
| 2.5         | 2.5         | 27         | 55         | 50600742          | VHW 2010 Spiraalboor             | 4-1    | 7.0         | 10          | 35         | 70         | 50600121                | HW 2032 Drevvelboren             | 4-6    |
| 2.5         | 2.5         | 27         | 55         | 50600743          | VHW 2010 Spiraalboor             | 4-1    | 7.0         | 10          | 65         | 105        | 50600255                | HW 2033 Drevvelboren             | 4-7    |
| 3.0         | 10          | 18         | 57.5       | 50600261          | VHW 2041 Deugelboor              | 4-9    | 7.0         | 10          | 65         | 105        | 50600256                | HW 2033 Drevvelboren             | 4-7    |
| 3.0         | 10          | 18         | 57.5       | 50600262          | VHW 2041 Deugelboor              | 4-9    | 8.0         | 10          | 12         | 57.5       | 50600389                | HW 2060 Verzinkboor              | 4-14   |
| 3.0         | 10          | 18         | 70         | 50600267          | VHW 2041 Deugelboor              | 4-9    | 8.0         | 10          | 12         | 57.5       | 50600390                | HW 2060 Verzinkboor              | 4-14   |
| 3.0         | 10          | 18         | 70         | 50600268          | VHW 2041 Deugelboor              | 4-9    | 8.0         | 10          | 12         | 70         | 50600391                | HW 2060 Verzinkboor              | 4-14   |
| 3.0         | 3.0         | 27         | 55         | 50600744          | VHW 2010 Spiraalboor             | 4-1    | 8.0         | 10          | 12         | 70         | 50600392                | HW 2060 Verzinkboor              | 4-14   |
| 3.0         | 3.0         | 27         | 55         | 50600745          | VHW 2010 Spiraalboor             | 4-1    | 8.0         | 10          | 22         | 57.5       | 50600134                | HW 2020 Doorgangsboor            | 4-2    |
| 3.0         | 10          | 27         | 70         | 50600376          | VHW 2022 Doorloopgatboor         | 4-4    | 8.0         | 10          | 22         | 57.5       | 50600135                | HW 2020 Doorgangsboor            | 4-2    |
| 3.0         | 10          | 27         | 70         | 50600588          | VHW 2022 Doorloopgatboor         | 4-4    | 8.0         | 10          | 25         | 57.5       | 50600645                | HW 2040 Drevvelboren             | 4-8    |
| 3.5         | 3.5         | 27         | 52         | 50600748          | VHW 2010 Spiraalboor             | 4-1    | 8.0         | 10          | 25         | 57.5       | 50600645                | HW 2040 Drevvelboren             | 4-8    |
| 3.5         | 3.5         | 27         | 52         | 50600749          | VHW 2010 Spiraalboor             | 4-1    | 8.0         | 10          | 27         | 57.5       | 50600108                | HW 2032 Drevvelboren             | 4-6    |
| 4.0         | 4.0         | 27         | 55         | 50600750          | VHW 2010 Spiraalboor             | 4-1    | 8.0         | 10          | 27         | 57.5       | 50600109                | HW 2032 Drevvelboren             | 4-6    |
| 4.0         | 4.0         | 27         | 55         | 50600751          | VHW 2010 Spiraalboor             | 4-1    | 8.0         | 10          | 30         | 57.5       | 50600178                | HW 2031 Drevvelboren             | 4-5    |
| 4.0         | 10          | 20         | 57.5       | 50600452          | VHW 2041 Deugelboor              | 4-9    | 8.0         | 10          | 30         | 57.5       | 50600179                | HW 2031 Drevvelboren             | 4-5    |
| 4.0         | 10          | 20         | 57.5       | 50600453          | VHW 2041 Deugelboor              | 4-9    | 8.0         | 10          | 35         | 70         | 50600122                | HW 2032 Drevvelboren             | 4-6    |
| 4.0         | 10          | 27         | 57.5       | 50600100          | HW 2032 Drevvelboren             | 4-6    | 8.0         | 10          | 35         | 70         | 50600123                | HW 2032 Drevvelboren             | 4-6    |
| 4.0         | 10          | 27         | 57.5       | 50600101          | HW 2032 Drevvelboren             | 4-6    | 8.0         | 10          | 35         | 70         | 50600123                | HW 2032 Drevvelboren             | 4-6    |
| 4.0         | 10          | 27         | 70         | 50600455          | VHW 2041 Deugelboor              | 4-9    | 8.0         | 10          | 35         | 70         | 50600138                | HW 2020 Doorgangsboor            | 4-2    |
| 4.0         | 10          | 27         | 70         | 50600456          | VHW 2041 Deugelboor              | 4-9    | 8.0         | 10          | 35         | 70         | 50600139                | HW 2020 Doorgangsboor            | 4-2    |
| 4.0         | 10          | 35         | 70         | 50600162          | HW 2032 Drevvelboren             | 4-6    | 8.0         | 10          | 35         | 70         | 50600273                | VHW 2041 Deugelboor              | 4-9    |
| 4.0         | 10          | 35         | 70         | 50600163          | HW 2032 Drevvelboren             | 4-6    | 8.0         | 10          | 35         | 70         | 50600274                | VHW 2041 Deugelboor              | 4-9    |
| 4.0         | 10          | 35         | 70         | 50600450          | VHW 2022 Doorgangsboor           | 4-4    | 8.0         | 10          | 35         | 70         | 50600374                | HW 2021 Doorgangsboor            | 4-3    |
| 4.0         | 10          | 35         | 70         | 50600451          | VHW 2022 Doorgangsboor           | 4-4    | 8.0         | 10          | 35         | 70         | 50600375                | HW 2021 Doorgangsboor            | 4-3    |
| 5.0         | 5.0         | 28         | 60         | 50600752          | VHW 2010 Spiraalboor             | 4-1    | 8.0         | 10          | 35         | 70         | 50600591                | VHW 2022 Doorgangsboor           | 4-4    |
| 5.0         | 5.0         | 28         | 60         | 50600753          | VHW 2010 Spiraalboor             | 4-1    | 8.0         | 10          | 35         | 70         | 50600652                | HW 2040 Drevvelboren             | 4-8    |
| 5.0         | 10          | 22         | 57.5       | 50600263          | VHW 2041 Deugelboor              | 4-9    | 8.0         | 10          | 35         | 70         | 50600653                | HW 2040 Drevvelboren             | 4-8    |
| 5.0         | 10          | 22         | 57.5       | 50600264          | VHW 2041 Deugelboor              | 4-9    | 8.0         | 10          | 36         | 70         | 50600694                | VHW 2042 hoogwaardige deugelboor | 4-10   |
| 5.0         | 10          | 25         | 57.5       | 50600132          | HW 2020 Doorgangsboor            | 4-2    | 8.0         | 10          | 36         | 70         | 50600695                | VHW 2042 hoogwaardige deugelboor | 4-10   |
| 5.0         | 10          | 25         | 57.5       | 50600133          | HW 2020 Doorgangsboor            | 4-2    | 8.0         | 10          | 40         | 70         | 50600379                | VHW 2022 Doorloopgatboor         | 4-4    |
| 5.0         | 10          | 25         | 57.5       | 50600640          | HW 2040 Drevvelboren             | 4-8    | 8.0         | 10          | 43         | 77         | 50600326                | HW 2020 Doorgangsboor            | 4-2    |
| 5.0         | 10          | 25         | 57.5       | 50600641          | HW 2040 Drevvelboren             | 4-8    | 8.0         | 10          | 43         | 77         | 50600327                | HW 2020 Doorgangsboor            | 4-2    |
| 5.0         | 10          | 27         | 57.5       | 50600102          | HW 2032 Drevvelboren             | 4-6    | 8.0         | 10          | 50         | 85         | 50600251                | HW 2033 Drevvelboren             | 4-7    |
| 5.0         | 10          | 27         | 57.5       | 50600103          | HW 2032 Drevvelboren             | 4-6    | 8.0         | 10          | 50         | 85         | 50600252                | HW 2033 Drevvelboren             | 4-7    |
| 5.0         | 10          | 27         | 57.5       | 50600370          | HW 2021 Doorgangsboor            | 4-3    | 8.0         | 10          | 65         | 105        | 50600257                | HW 2033 Drevvelboren             | 4-7    |
| 5.0         | 10          | 27         | 57.5       | 50600371          | HW 2021 Doorgangsboor            | 4-3    | 8.0         | 10          | 65         | 105        | 50600258                | HW 2033 Drevvelboren             | 4-7    |
| 5.0         | 10          | 30         | 57.5       | 50600174          | HW 2031 Drevvelboren             | 4-5    | 8.2         | 10          | 27         | 57.5       | 50600198                | HW 2032 Drevvelboren             | 4-6    |
| 5.0         | 10          | 30         | 57.5       | 50600175          | HW 2031 Drevvelboren             | 4-5    | 8.2         | 10          | 27         | 57.5       | 50600199                | HW 2032 Drevvelboren             | 4-6    |
| 5.0         | 10          | 30         | 70         | 50600269          | VHW 2041 Deugelboor              | 4-9    | 9.0         | 10          | 27         | 57.5       | 50600110                | HW 2032 Drevvelboren             | 4-6    |
| 5.0         | 10          | 30         | 70         | 50600270          | VHW 2041 Deugelboor              | 4-9    | 9.0         | 10          | 27         | 57.5       | 50600111                | HW 2032 Drevvelboren             | 4-6    |
| 5.0         | 10          | 35         | 70         | 50600116          | HW 2032 Drevvelboren             | 4-6    | 9.0         | 10          | 35         | 70         | 50600124                | HW 2032 Drevvelboren             | 4-6    |
| 5.0         | 10          | 35         | 70         | 50600117          | HW 2032 Drevvelboren             | 4-6    | 9.0         | 10          | 35         | 70         | 50600125                | HW 2032 Drevvelboren             | 4-6    |
| 5.0         | 10          | 35         | 70         | 50600136          | HW 2020 Doorgangsboor            | 4-2    | 18          | 10          | 57.5       | 50600504   | HW 2050 Cilinderkopboor | 4-11                             |        |
| 5.0         | 10          | 35         | 70         | 50600137          | HW 2020 Doorgangsboor            | 4-2    | 18          | 10          | 57.5       | 50600505   | HW 2050 Cilinderkopboor | 4-11                             |        |
| 5.0         | 10          | 35         | 70         | 50600372          | HW 2021 Doorgangsboor            | 4-3    | 20          | 10          | 57.5       | 50600506   | HW 2050 Cilinderkopboor | 4-11                             |        |
| 5.0         | 10          | 35         | 70         | 50600373          | HW 2021 Doorgangsboor            | 4-3    | 20          | 10          | 57.5       | 50600507   | HW 2050 Cilinderkopboor | 4-11                             |        |
| 5.0         | 10          | 35         | 70         | 50600378          | VHW 2022 Doorloopgatboor         | 4-4    | 20          | 10          | 70         | 50600532   | HW 2050 Cilinderkopboor | 4-11                             |        |
| 5.0         | 10          | 35         | 70         | 50600590          | VHW 2022 Doorgangsboor           | 4-4    | 20          | 10          | 70         | 50600533   | HW 2050 Cilinderkopboor | 4-11                             |        |
| 5.0         | 10          | 35         | 70         | 50600648          | HW 2040 Drevvelboren             | 4-8    | 20          | 10          | 90         | 50600553   | HW 2051 Cilinderkopboor | 4-12                             |        |
| 5.0         | 10          | 35         | 70         | 50600649          | HW 2040 Drevvelboren             | 4-8    | 22          | 10          | 57.5       | 50600508   | HW 2050 Cilinderkopboor | 4-11                             |        |
| 5.0         | 10          | 36         | 70         | 50600690          | VHW 2042 hoogwaardige deugelboor | 4-10   | 22          | 10          | 57.5       | 50600509   | HW 2050 Cilinderkopboor | 4-11                             |        |
| 5.0         | 10          | 36         | 70         | 50600691          | VHW 2042 hoogwaardige deugelboor | 4-10   | 25          | 10          | 57.5       | 50600510   | HW 2050 Cilinderkopboor | 4-11                             |        |
| 5.0         | 10          | 45         | 77         | 50600324          | HW 2020 Doorgangsboor            | 4-2    | 25          | 10          | 57.5       | 50600511   | HW 2050 Cilinderkopboor | 4-11                             |        |
| 5.0         | 10          | 45         | 77         | 50600325          | HW 2020 Doorgangsboor            | 4-2    | 25          | 10          | 70         | 50600534   | HW 2050 Cilinderkopboor | 4-11                             |        |
| 5.0         | 10          | 50         | 85         | 50600249          | HW 2033 Drevvelboren             | 4-7    | 25          | 10          | 70         | 50600535   | HW 2050 Cilinderkopboor | 4-11                             |        |
| 5.0         | 10          | 50         | 85         | 50600250          | HW 2033 Drevvelboren             | 4-7    | 25          | 10          | 90         | 50600561   | HW 2051 Cilinderkopboor | 4-12                             |        |
| 6.0         | 10          | 25         | 57.5       | 50600144          | HW 2020 Doorgangsboor            | 4-2    | 26          | 10          | 57.5       | 50600512   | HW 2050 Cilinderkopboor | 4-11                             |        |
| 6.0         | 10          | 25         | 57.5       | 50600145          | HW 2020 Doorgangsboor            | 4-2    | 26          | 10          | 57.5       | 50600513   | HW 2050 Cilinderkopboor | 4-11                             |        |
| 6.0         | 10          | 25         | 57.5       | 50600642          | HW 2040 Drevvelboren             | 4-8    | 26          | 10          | 70         | 50600536   | HW 2050 Cilinderkopboor | 4-11                             |        |
| 6.0         | 10          | 25         | 57.5       | 50600643          | HW 2040 Drevvelboren             | 4-8    | 26          | 10          | 70         | 50600537   | HW 2050 Cilinderkopboor | 4-11                             |        |
| 6.0         | 10          | 27         | 57.5       | 50600104          | HW 2032 Drevvelboren             | 4-6    | 30          | 10          | 57.5       | 50600514   | HW 2050 Cilinderkopboor | 4-11                             |        |
| 6.0         | 10          | 27         | 57.5       | 50600105          | HW 2032 Drevvelboren             | 4-6    | 30          | 10          | 57.5       | 50600515   | HW 2050 Cilinderkopboor | 4-11                             |        |
| 6.0         | 10          | 30         | 57.5       | 50600176          | HW 2031 Drevvelboren             | 4-5    | 30          | 10          | 70         | 50600538   | HW 2050 Cilinderkopboor | 4-11                             |        |
| 6.0         | 10          | 30         | 57.5       | 50600177          | HW 2031 Drevvelboren             | 4-5    | 30          | 10          | 70         | 50600539   | HW 2050 Cilinderkopboor | 4-11                             |        |
| 6.0         | 10          | 30         | 70         | 50600271          | VHW 2041 Deugelboor              | 4-9    | 30          | 10          | 90         | 50600569   | HW 2051 Cilinderkopboor | 4-12                             |        |
| 6.0         | 10          | 30         | 70         | 50600272          | VHW 2041 Deugelboor              | 4-9    | 32          | 10          | 90         | 50600571   | HW 2051 Cilinderkopboor | 4-12                             |        |
| 6.0         | 10          | 35         | 100        | 50600380          | VHW 2022 Doorloopgatboor         | 4-4    | 35          | 10          | 57.5       | 50600516   | HW 2050 Cilinderkopboor | 4-11                             |        |
| 6.0         | 10          | 35         | 70         | 50600118          | HW 2032 Drevvelboren             | 4-6    | 35          | 10          | 57.5       | 50600517   | HW 2050 Cilinderkopboor | 4-11                             |        |
| 6.0         | 10          | 35         | 70         | 50600119          | HW 2032 Drevvelboren             | 4-6    | 35          | 10          | 70         | 50600540   | HW 2050 Cilinderkopboor | 4-11                             |        |
| 6.0         | 10          | 35         | 70         | 50600318          | HW 2020 Doorgangsboor            | 4-2    | 35          | 10          | 70         | 50600541   | HW 2050 Cilinderkopboor | 4-11                             |        |
| 6.0         | 10          | 35         | 70         | 50600319          | HW 2020 Doorgangsboor            | 4-2    | 35          | 10          | 90         | 50600575   | HW 2051 Cilinderkopboor | 4-12                             |        |
| 6.0         | 10          | 35         | 70         | 50600650          | HW 2040 Drevvelboren             | 4-8    | 40          | 10          | 57.5       | 50600687   | HW 2050 Cilinderkopboor | 4-11                             |        |
| 6.0         | 10          | 35         | 70         | 50600651          | HW 2040 Drevvelboren             | 4-8    | 40          | 10          | 57.5       | 50600688   | HW 2050 Cilinderkopboor | 4-11                             |        |
| 6.0         | 10          | 36         | 70         | 50600692          | VHW 2042 hoogwaardige deugelboor | 4-10   |             |             |            |            |                         |                                  |        |

# Alfabetische productenlijst

| Omschrijving  | Pagina   | Omschrijving                                   | Pagina                |
|---|----------|--|-----------------------|
| 1   |          | 4  |                       |
| 1101 Groefzaagblad                                      | HW 2-4   | 4000 Groef- en veergereedschappen              | HS 2-41               |
| 1103G Harsgalfrees                                      | HW 2-3   | 4010 Groef- en veergereedschap HW - Silverline | HW 2-43               |
| 1103L Groeffrees - voor Lamello®                        | HW 2-1   | 464 HS stokkenfreesen                          | HS 2-38               |
| 1503 Groeffrezen  | HW 2-8   | 5  |                       |
| 1520 Handgreeprezen                                     | HW 3-34  | 520-1 Hydro-schaafkoppen                       | HS 2-30               |
| 1521 Zwaluwstaartfrees                                  | HW 3-33  | 521-1 Hydro-profielschaafkoppen                | 2-35                  |
| 1522 Fasefrees  | HW 3-33  | 525 Blankets met rugvertanding HS              | HS 2-37               |
| 1523 Afrond-fase-freeset Z=2                            | HW 3-35  | 525 Rugvertande profielfrees                   | 2-33                  |
| 1524 Leuningrezen                                       | HW 3-36  | 5540 Bossingrezen - Silverline                 | HW 2-20               |
| 1534-2 Verlijmprofielfrezen                             | HW 2-26  | 5554 Contraprofielgarnituur                    | HW 2-24               |
| 1547 Universele Euro-Profiel frezen - Silverline        | 2-22     | 5556 Verstek-verlijmfrezen                     | HW 2-25               |
| 1568 Keermessen groeffrees - Silverline - voor Lamello® | HW 2-2   | 5561 Keermesen-Groeffrezen - Silverline        | HW 2-9                |
| 1580 Zwenkfreesen                                       | HW 2-17  | 5562 Keermesen-Groeffrezen - Silverline        | HW 2-10               |
| 1581 Zwenkfrees   | HW 3-31  | 5567 Contraprofiel frezen                      | HW 2-23               |
| 1586 Groef- en sponningrezen- Silverline                | HW 2-11  | 556-1 Schaafkoppen                             | HS 2-29               |
| 1591 Siergroeffrees                                     | HW 3-30  | 5570 Spiraal schaafkoppen                      | HW 2-28               |
| 1593 V-groeffrezen                                      | HW 3-34  | 5572 Vlakfrees- en sponningfrees               | 3-27                  |
| 1594 Vlakfrees  | HW 3-26  | 5573 Folding-fasfrees                          | 3-32                  |
| 2   |          | 5575 Spiraal schaafkoppen                      | HW 3-28               |
| 2010 Spiraalboor  | VHW 4-1  | 5576 Groef- en sponningfrees                   | 3-29                  |
| 2020 Doorgangsboor                                      | HW 4-2   | 569 Schaafmes HW belegd                        | HW 2-32               |
| 2021 Doorgangsboor                                      | HW 4-3   | 569 Schaafmes, HSS - 18%                       | HS 2-31               |
| 2022 Doorgangsboor                                      | VHW 4-4  | A  |                       |
| 2031 Drevelboren  | HW 4-5   | Aantrekbout                                    | 5-11                  |
| 2032 Drevelboren  | HW 4-6   | Adapter met cilinderschacht                    | 5-1                   |
| 2033 Drevelboren  | HW 4-7   | B  |                       |
| 2040 Drevelboren  | HW 4-8   | BKS (NAIL)                                     | HW 1-16               |
| 2041 Drevelboren  | VHW 4-9  | Boor-adpater                                   | 5-6                   |
| 2042 hoogwaardige deugelboor                            | VHW 4-10 | Boor-adpater - Combisysteem                    | 5-7                   |
| 2050 Cilinderkopboor                                    | HW 4-11  | C  |                       |
| 2051 Cilinderkopboor                                    | HW 4-12  | Cirkelzaagbladen-set HW - een klus voor twee   | HW 1-26               |
| 2060 Verzinkboor  | HW 4-14  | CNC booropname                                 | 5-8                   |
| 2061 Opsteekverzinker                                   | HW 4-13  | CNC combizaagopname HSK 63F                    | 5-3                   |
| 2062 Verzinker  | HW 4-15  | Conusreiniger                                  | 5-21                  |
| 2231 Schachtfrees                                       | HW 3-1   | D  |                       |
| 2233 Schachtfrees                                       | HW 3-2   | Driehoek-voorsnijders                          | HW 6-8                |
| 2235 Schachtfrees                                       | HW 3-3   | G  |                       |
| 2236 Schachtfrees                                       | HW 3-4   | Groefmessen                                    | HW 2-2, 2-8, 2-9, 6-8 |
| 2237 Schachtfrees                                       | HW 3-5   | H  |                       |
| 2254 Slotkasten-schrobfrees                             | VHW 3-12 | Handcirkelzaagbladen - Set HW                  | HW 1-13               |
| 2257 Afwerkfrees  | VHW 3-8  | Handschaaf-omkeermessen                        | HW 6-10               |
| 2257-1 Afwerkfrees                                      | VHW 3-9  | High-tech krimpopname                          | 5-19                  |
| 2257-2 Afwerkfrees                                      | VHW 3-10 | HKS - Board                                    | HW 1-6                |
| 2265 Schrobfrees  | VHW 3-6  | HKS - DP - Accuhandcirkelzagen                 | DP 1-2                |
| 2265-1 Schrobfrees                                      | VHW 3-7  | HKS - L  | DP 1-8                |
| 2268 Ventilatie schrobfrees                             | VHW 3-11 | HKS - L2                                       | DP 1-9                |
| 2269 Ventilatie afwerkfrees                             | VHW 3-11 | HKS - LR                                       | DP 1-7                |
| 3   |          | HKS - Massief                                  | HW 1-5                |
| 3103L Groeffrees - voor Lamello®                        | DP 2-1   | HKS - Massief - Accuhandcirkelzagen            | HW 1-1                |
| 3140L Groeffrees voor Lamello Clamex P®                 | DP 2-2   | HKS - Mega-Steel - Accuhandcirkelzagen         | HT 1-3                |
| 3501 Schachtfrees                                       | DP 3-13  | HKS - nn-System DP flex                        | DP 1-10               |
| 3502 Bovenfrees   | DP 3-14  | HKS - Unisteeel - Accuhandcirkelzagen          | HW 1-4                |
| 3503 High performance schachtfrees                      | 3-17     | HRP - nn-System DP flex                        | DP 1-34               |
| 3505 High performance schachtfrees                      | DP 3-19  | Hydro-opname ps-System met HSK63F              | 5-16                  |
| 3506 High performance schachtfrees CM                   | DP 3-21  | K  |                       |
| 3506 High performance schachtfrees CM                   | DP 3-21  | K + G negatief                                 | HW 1-15               |
| 3507 High performance kantenfrees                       | DP 3-22  | KDF - Industry                                 | HW 1-32               |
| 3508 Vlak- en sponningschachtfrees                      | DP 3-26  | KDF - Industry Plus                            | HW 1-32               |
| 3509 Highperformance bovenfrees                         | 3-18     | KDF - Industry Professionell                   | HW 1-33               |
| 3509 Highperformance bovenfrees                         | 3-18     | KDF - Industry - Negatief                      | HW 1-31               |
| 3509 Highperformance bovenfrees                         | 3-18     | KKE  | HW 1-60               |
| 3510 Schrobfrees DP                                     | 3-15     | KKM  | HW 1-59               |
| 3511 Highperformance Schrobfrees DP                     | 3-15     | KKO  | HW 1-58               |
| 3512 Profiel-groeffrees HW - voor Lamello Clamex P®     | 3-37     | KKS - Hard plastic negatief                    | HW 1-57               |
| 3513 High performance schachtfrees CM                   | DP 3-20  | KKS - Plastic                                  | HW 1-55               |
| 3518 Profiel-groeffrees DP - voor Lamello Clamex P®     | 3-38     | L  |                       |
| 3519 Profiel-groeffrees VHW - voor Lamello Clamex P®    | 3-37     | LWR  | HW 1-47               |
| 3565 Kanten-afrondfrees                                 | DP 2-18  | M  |                       |
| 3565-1 Kanten-afrondfrees                               | DP 2-18  | Matador 5                                      | HW 1-23               |
| 3565-2 Kanten-afrondfrees CM                            | DP 2-19  | Mega-Steel                                     | HT 1-54               |
| 3584 Voegenfrees  | DP 2-12  | Mini-omkeermessen                              | HW 6-9                |
| 3585 Voegenfrees LowNoise                               | DP 2-14  | Montage voorziening                            | 5-21                  |
| 3585 Voegenfrees DP airFace                             | DP 2-13  | N  |                       |
| 3585-2 voegenfrees DP - HOLZ-HER - AirStream-systeem    | DP 2-14  | NE - Kap - Negatief - Profiel 'G7'             | HW 1-51               |
| 3588-2 Strijkrezen airFace                              | 2-16     | NE - Positief - Profiel 'G7'                   | HW 1-50               |
| 3600 p-systeem highperformance bovenfrees               | DP 3-23  | NE-negatief                                    | HW 1-14, 1-49         |
| 3600 p-systeem highperformance bovenfrees               | DP 3-23  | NE-positief                                    | HW 1-48               |
| 3610 p-systeem highperformance-voeg-bovenfrees          | DP 3-24  | NK   | HW 2-5                |

# Alfabetische productenlijst

| Omschrijving                                       |    | Pagina                              |
|--|----|-------------------------------------|
| NK3VS  | HW | 2-7                                 |
| NKP  | HW | 2-5                                 |
| O  |    |                                     |
| OKW  | HW | 1-46                                |
| Omkeermessen                                       | HW | 6-5                                 |
| Omkeermessen HW                                    | HW | 3-2                                 |
| Omkeermessen - Voorsnijders                        | HW | 2-10, 2-11, 2-24, 2-44,<br>2-9, 6-7 |
| Opspandoorn met HSK-63F                            |    | 5-20                                |
| P  |    |                                     |
| Parat - negatief (HKS)                             | HW | 1-12                                |
| Planet   | HW | 1-46                                |
| Preciespantangen - 415E/OZ16                       |    | 5-14                                |
| Preciespantangen - 430E/ER25, 470E/ER32, 472E/ER40 |    | 5-15                                |
| Preciespantangen - 462E/OZ25                       |    | 5-13                                |
| Profiel-omkeermessen HW                            | HW | 2-23                                |
| Reduceerringen - gekarteld                         |    | 1-61                                |
| Reduceerringen - vlak                              |    | 1-63                                |
| RNK  | DP | 2-7                                 |
| RNK-Matador 5                                      | HW | 2-6                                 |
| RS2  | HW | 1-29                                |
| RSK  | DP | 1-44                                |
| RSK  | DP | 1-28                                |
| RSK - nn-System                                    | HW | 1-26                                |
| RSK - nn-System DP flex                            | DP | 1-35                                |
| RSK - nn-systeem DP flex - verstelbaar             | DP | 1-36                                |
| RSK-WS   |    | 1-45                                |
| RSVS   | DP | 1-31                                |
| RSVS   | HW | 1-30                                |
| Ruimer-omkeermessen                                | HW | 6-6                                 |
| S  |    |                                     |
| Siergroeffrees met HW-omkeermessen                 | HW | 3-30                                |
| Spantangenopname met SK-schacht met tandkrans      |    | 5-10                                |
| Spantangopname met HSK-63F                         |    | 5-12                                |
| Spantangopname met SK-schacht                      |    | 5-9                                 |
| Steel  | HW | 1-53                                |
| T  |    |                                     |
| TFP  | DP | 1-42                                |
| TFP  | HW | 1-41                                |
| TRF  | HW | 1-24                                |
| TRF - 1  | HW | 1-25                                |
| TRIBOS high-tech spantanghouder                    |    | 5-18                                |
| U  |    |                                     |
| Unisteel   | HW | 1-52                                |
| Unisteel (HKS)                                     | HW | 1-11                                |
| Universele reduceerhulzen                          |    | 5-17                                |
| Z  |    |                                     |
| Zagen-opname HSK 63F                               |    | 5-4                                 |
| ZFL  | HW | 1-17                                |
| ZQW  | HW | 1-14, 1-20                          |
| ZW   | HW | 1-21                                |
| ZWS  | HW | 1-21                                |
| ZWS-1  | HW | 1-22                                |
| ZWZ  | HW | 1-18                                |

## Bestelnr. lijst

| Bestelnr. | Pagina           | Bestelnr. | Pagina                          | Bestelnr. | Pagina           | Bestelnr. | Pagina      |
|-----------|------------------|-----------|---------------------------------|-----------|------------------|-----------|-------------|
| 000104    | 1-62             | 161831    | 1-63                            | 173651    | o 5-15           | 180357    | 2-25, 2-26  |
| 000107    | s 1-62           | 161886    | 1-62                            | 173652    | 5-15             | 180358    | 5-13        |
| 000110    | s 1-62           | 161887    | 1-26, 1-62                      | 173653    | 5-15             | 180381    | 5-8         |
| 000111    | 1-62             | 161945    | 1-62                            | 173654    | 5-15             | 180382    | 5-8         |
| 000112    | 1-62             | 161946    | 1-62                            | 173655    | o 5-15           | 180383    | o 2-38, 5-8 |
| 000113    | 1-62             | 161949    | # 1-62                          | 173656    | o 5-15           | 180434    | 2-26        |
| 000114    | 1-62             | 161962    | 1-63                            | 173657    | 5-15             | 180435    | 2-26        |
| 000117    | 1-62             | 161987    | s 5-7                           | 173658    | o 5-15           | 180436    | 2-26        |
| 000118    | 1-62             | 162645    | 3-3                             | 173659    | o 5-15           | 180437    | 2-26        |
| 000119    | 1-62             | 163161    | 3-29, 3-3, 3-30, 3-32, 3-4, 3-5 | 173660    | 5-15             | 180438    | 2-26        |
| 000120    | 1-62             | 163223    | 3-30                            | 173796    | 3-2              | 180439    | 2-26        |
| 000125    | 1-62             | 163703    | 2-2, 2-8                        | 175637    | o 5-11, 5-9      | 180449    | 3-2         |
| 000127    | s 1-62           | 163704    | 2-2, 2-8                        | 175722    | o 3-1            | 180470    | 2-25        |
| 000128    | 1-62             | 163706    | 2-30, 2-35                      | 175724    | o 3-1            | 180710    | 5-18        |
| 000129    | 1-62             | 163707    | 2-30, 2-35                      | 175726    | o 3-1            | 180711    | 5-18        |
| 000130    | 1-62             | 163925    | 2-2, 2-8                        | 175790    | 5-9              | 180828    | o 5-18      |
| 000132    | 1-62             | 164005    | 5-4                             | 175792    | 5-10             | 180829    | o 5-18      |
| 000134    | s 1-62           | 164344    | 2-2, 2-8                        | 175815    | 5-13             | 180836    | 5-18        |
| 000135    | s 1-62           | 165049    | 5-7                             | 175817    | 5-13             | 180839    | 1-30        |
| 000137    | 1-62             | 165916    | 2-25                            | 175820    | 5-13             | 180840    | 1-30, 2-25  |
| 000138    | 1-63             | 166090    | 2-17, 2-23, 2-24, 3-31          | 175823    | 5-13             | 180888    | 5-18        |
| 000139    | s 1-63           | 166091    | 2-25, 2-26, 5-16                | 175826    | 5-13             | 180899    | 5-18        |
| 000142    | 1-63             | 166092    | 2-24, 2-28, 3-27, 3-28, 3-29    | 175829    | 5-15             | 180902    | 5-18        |
| 000145    | 1-63             | 166499    | 3-1                             | 175830    | 5-15             | 180911    | 5-21        |
| 000146    | s 1-63           | 166709    | 5-3                             | 175831    | o 5-15           | 180912    | o 5-15      |
| 000147    | 1-63             | 167068    | 4-13, 5-7                       | 175832    | o 5-15           | 180913    | 5-15        |
| 000148    | 1-63             | 167817    | 2-30, 2-35                      | 175833    | 5-15             | 180914    | o 5-15      |
| 000151    | 1-63             | 167826    | 5-1                             | 175834    | 5-15             | 181159    | o 5-18      |
| 000153    | 1-63             | 167966    | 3-4, 3-5                        | 175835    | o 5-15           | 181191    | o 2-29      |
| 000154    | s 1-63           | 168108    | 2-29                            | 175836    | 5-15             | 181193    | 5-20        |
| 000156    | 1-63             | 168236    | 3-4                             | 175837    | 5-15             | 181194    | 5-20        |
| 000159    | 1-63             | 168237    | 3-1                             | 175838    | o 5-15           | 181466    | 2-30, 2-35  |
| 000161    | 1-63             | 168238    | 3-1                             | 175839    | o 5-15           | 181986    | o 5-15      |
| 000162    | 1-63             | 168239    | 3-1                             | 175840    | o 5-15           | 181987    | 5-15        |
| 000163    | s 1-63           | 168703    | 2-33, 5-16                      | 175841    | o 5-15           | 181988    | 5-15        |
| 000164    | 1-63             | 168739    | o 5-14                          | 175842    | o 5-15           | 181989    | 5-15        |
| 000166    | s 1-63           | 168740    | 5-14                            | 175851    | 5-10, 5-9        | 181990    | o 5-15      |
| 000171    | 1-63             | 168741    | 5-14                            | 176103    | 5-11             | 181991    | 5-15        |
| 000172    | s 1-63           | 168742    | 5-13                            | 176199    | 2-24, 3-27, 3-29 | 182112    | 2-28, 3-28  |
| 000175    | s 1-63           | 168743    | 5-13                            | 176200    | o 5-11           | 182304    | 5-17        |
| 000177    | s 1-63           | 168744    | 5-13                            | 177020    | o 5-11           | 182305    | 5-17        |
| 000178    | s 1-63           | 168745    | 5-13                            | 177021    | 5-11             | 182306    | 5-17        |
| 000179    | s 1-63           | 168814    | o 5-2                           | 178289    | 3-29             | 182307    | 5-17        |
| 001608    | 5-7              | 168815    | 5-2                             | 178760    | 5-20             | 182308    | 5-17        |
| 001617    | 2-17, 2-23, 2-24 | 168893    | 3-3, 3-32                       | 178761    | 5-10, 5-9        | 182309    | 5-17        |
| 001870    | 5-3              | 169293    | 5-11                            | 178762    | o 5-9            | 182310    | 5-17        |
| 003079    | 3-29             | 169294    | o 5-11                          | 179170    | 5-12             | 182311    | 5-17        |
| 003570    | 5-7              | 169299    | 5-10, 5-12, 5-9                 | 179198    | o 2-29           | 182441    | 3-27        |
| 003571    | 5-7              | 170371    | s 5-7                           | 179199    | o 2-29           | 182467    | 5-21        |
| 003572    | 5-7              | 170372    | s 5-7                           | 179200    | o 2-29           | 182653    | 5-17        |
| 003573    | 5-7              | 170779    | o 5-14                          | 179205    | o 2-29           | 182655    | 5-17        |
| 003574    | 5-7              | 170780    | 5-14                            | 179221    | o 2-33           | 183022    | o 5-17      |
| 003575    | 5-7              | 170781    | 5-14                            | 179222    | o 2-33           | 183023    | o 5-17      |
| 008002    | 5-7              | 170782    | 5-13                            | 179223    | o 2-33           | 183024    | o 5-17      |
| 008003    | 5-7              | 170783    | 5-13                            | 179224    | o 2-33           | 183025    | 5-17        |
| 009672    | 4-13, 5-6        | 171067    | 3-29                            | 179225    | o 2-33           | 183026    | 5-17        |
| 009674    | 2-29             | 171111    | o 3-4                           | 179226    | o 2-33           | 183027    | o 5-17      |
| 009675    | 2-17             | 171113    | o 3-4                           | 179227    | o 2-33           | 183028    | o 5-17      |
| 010571    | 1-62             | 171114    | o 3-4                           | 179228    | o 2-33           | 183029    | o 5-17      |
| 010577    | 1-63             | 171386    | 5-2                             | 179229    | o 2-33           | 183030    | o 5-17      |
| 010677    | o 5-7            | 171394    | 5-1                             | 179230    | o 2-33           | 183032    | 5-17        |
| 010683    | o 5-7            | 172101    | 5-5                             | 179231    | o 2-33           | 183034    | 5-17        |
| 016848    | 1-62             | 172102    | 5-5                             | 179232    | o 2-33           | 183036    | 5-17        |
| 058411    | o 5-7            | 172103    | 5-5                             | 179233    | o 2-33           | 183038    | o 5-17      |
| 058412    | o 5-7            | 172104    | 5-5                             | 179234    | o 2-33           | 183040    | 5-17        |
| 058413    | 5-7              | 172113    | 3-31, 5-11                      | 179235    | o 2-33           | 183055    | o 5-7       |
| 058414    | 5-7              | 172828    | 5-11                            | 179236    | o 2-33           | 183081    | 5-19        |
| 059299    | 5-7              | 172921    | 3-31, 5-11                      | 179339    | 5-11             | 183082    | 5-19        |
| 059300    | 5-7              | 173639    | 5-9                             | 180005    | 4-15, 5-6        | 183083    | 5-19        |
| 161281    | o 5-7            | 173641    | 5-11, 5-9                       | 180013    | 5-13             | 183084    | 5-19        |
| 161282    | o 5-7            | 173644    | 5-10                            | 180215    | 5-13             | 183085    | 5-19        |
| 161283    | o 5-7            | 173646    | 5-10, 5-11                      | 180216    | 5-13             | 183086    | 5-19        |
| 161284    | o 5-7            | 173647    | o 5-15                          | 180257    | 5-18             | 183087    | 5-19        |
| 161285    | o 5-7            | 173648    | o 5-15                          | 180258    | 5-18             | 183275    | 5-6         |
| 161286    | 5-7              | 173649    | o 5-15                          | 180261    | 5-18             | 183276    | 5-6         |
| 161287    | 5-7              | 173650    | 5-15                            | 180263    | 5-18             | 183277    | 5-6         |
| 161680    | 5-7              |           |                                 | 180264    | 5-18             | 183278    | 5-6         |
| 161681    | 5-7              |           |                                 | 180340    | 2-25, 2-26       | 183279    | 5-6         |
| 161830    | 1-62             |           |                                 |           |                  | 183280    | 5-6         |

## Bestelnr. lijst

| Bestelnr. | Pagina     | Bestelnr. | Pagina     | Bestelnr. | Pagina | Bestelnr. | Pagina |
|-----------|------------|-----------|------------|-----------|--------|-----------|--------|
| 183310    | 5-4        | 830156    | o 5-14     | 50110228  | 1-6    | 50188360  | 2-4    |
| 183668    | 2-44       | 830236    | o 5-14     | 50110237  | 1-7    | 50188361  | 2-4    |
| 183719    | o 5-18     | 50005542  | 2-26       | 50110242  | 1-5    | 50188362  | 2-4    |
| 183720    | o 5-18     | 50100193  | o 1-21     | 50110243  | 1-5    | 50188363  | 2-4    |
| 183721    | o 5-18     | 50100525  | 1-47       | 50110244  | 1-5    | 50188364  | 2-4    |
| 183747    | 5-20       | 50100528  | 1-47       | 50110247  | 1-5    | 50188365  | 2-4    |
| 183748    | 5-20       | 50104061  | 1-5        | 50110248  | 1-5    | 50188366  | 2-4    |
| 183749    | 3-29, 5-20 | 50110001  | 1-6        | 50110250  | o 1-5  | 50188367  | 2-4    |
| 183803    | o 5-13     | 50110003  | 1-6        | 50110251  | 1-5    | 50188368  | 2-4    |
| 183804    | 5-13       | 50110006  | 1-6        | 50110252  | 1-5    | 50188369  | 2-4    |
| 183805    | 5-13       | 50110011  | 1-5        | 50110253  | 1-5    | 50188370  | 2-4    |
| 183806    | 5-13       | 50110012  | 1-6        | 50110255  | 1-6    | 50188371  | 2-4    |
| 183807    | o 5-13     | 50110017  | 1-5        | 50110256  | 1-20   | 50188372  | 2-4    |
| 183808    | o 5-13     | 50110018  | 1-6        | 50110266  | o 1-6  | 50188373  | 2-4    |
| 184061    | 5-20       | 50110028  | 1-5        | 50110267  | o 1-6  | 50188375  | 2-4    |
| 184275    | 2-25       | 50110029  | 1-6        | 50110268  | o 1-6  | 50188376  | 2-4    |
| 184276    | 5-2        | 50110039  | 1-5        | 50110282  | o 1-5  | 50188377  | 2-4    |
| 184277    | 5-2        | 50110040  | 1-6        | 50110286  | 1-5    | 50188378  | 2-4    |
| 184304    | 5-2        | 50110041  | 1-6        | 50111160  | 1-13   | 50188379  | 2-4    |
| 184305    | 5-2        | 50110042  | 1-5        | 50111163  | 1-13   | 50188380  | 2-4    |
| 184306    | 5-16       | 50110051  | 1-5        | 50111190  | 1-13   | 50188381  | 2-4    |
| 184307    | 5-16       | 50110053  | 1-6        | 50111193  | 1-13   | 50188382  | 2-4    |
| 184308    | 5-16       | 50110054  | 1-13, 1-5  | 50111216  | 1-14   | 50188383  | 2-4    |
| 184309    | 5-16       | 50110055  | 1-13, 1-6  | 50111235  | 1-14   | 50188384  | 2-4    |
| 184724    | 5-16       | 50110056  | 1-13, 1-6  | 50111250  | 1-14   | 50188385  | 2-4    |
| 184725    | 5-16       | 50110057  | 1-5        | 50112013  | o 1-16 | 50188386  | 2-4    |
| 184726    | 5-16       | 50110058  | 1-6        | 50169682  | 2-5    | 50188387  | 2-4    |
| 184835    | 5-3        | 50110059  | 1-6        | 50169683  | 2-5    | 50389261  | s 2-38 |
| 184836    | 5-3        | 50110060  | 1-5        | 50169684  | 2-5    | 50389262  | s 2-38 |
| 184837    | 5-3        | 50110061  | 1-6        | 50169685  | 2-5    | 50389263  | s 2-38 |
| 184838    | 5-3        | 50110062  | 1-6        | 50182686  | 2-19   | 50389264  | s 2-38 |
| 184839    | 5-3        | 50110064  | o 1-21     | 50183692  | 4-3    | 50389265  | s 2-38 |
| 184840    | 5-3        | 50110069  | 1-5        | 50183693  | 4-3    | 50389266  | s 2-38 |
| 184841    | 5-3        | 50110070  | 1-6        | 50184083  | # 3-24 | 50389267  | s 2-38 |
| 184842    | 5-3        | 50110071  | 1-6        | 50184380  | 3-23   | 50389268  | s 2-38 |
| 184843    | 5-3        | 50110075  | 1-5        | 50184384  | 3-23   | 50389269  | s 2-38 |
| 184844    | 5-3        | 50110076  | 1-6        | 50184772  | 3-25   | 50389270  | s 2-38 |
| 184845    | 5-3        | 50110077  | o 1-6      | 50185970  | 2-16   | 50389271  | s 2-38 |
| 184846    | 5-3        | 50110078  | 1-5        | 50185971  | 2-16   | 50389272  | s 2-38 |
| 184890    | 5-12, 5-9  | 50110079  | 1-6        | 50185972  | 2-16   | 50389273  | s 2-38 |
| 185140    | 3-32       | 50110080  | 1-6        | 50185973  | 2-16   | 50389274  | s 2-38 |
| 185250    | 2-16       | 50110081  | 1-5        | 50186031  | 2-15   | 50389275  | s 2-38 |
| 185274    | 3-28       | 50110082  | o 1-5      | 50186037  | 2-15   | 50389276  | s 2-38 |
| 185275    | 5-13       | 50110083  | 1-6        | 50186038  | 2-15   | 50400021  | s 2-32 |
| 185292    | 2-16       | 50110084  | 1-6        | 50186047  | 2-16   | 50400023  | s 2-32 |
| 185293    | 2-16       | 50110086  | 1-6        | 50186048  | 2-16   | 50400024  | s 2-32 |
| 185497    | 5-3        | 50110087  | 1-6        | 50186049  | 2-16   | 50400025  | s 2-32 |
| 185520    | 5-19       | 50110089  | 1-13, 1-7  | 50186050  | 2-16   | 50400026  | s 2-32 |
| 185666    | 5-3        | 50110090  | 1-13, 1-7  | 50186051  | 2-16   | 50400027  | s 2-32 |
| 185974    | 2-16       | 50110091  | 1-7        | 50186052  | 2-16   | 50400028  | s 2-32 |
| 186075    | 2-16       | 50110095  | 1-5        | 50186055  | 2-16   | 50400029  | s 2-32 |
| 186076    | 2-15       | 50110096  | 1-7        | 50186056  | 2-16   | 50400030  | s 2-32 |
| 186077    | 2-15       | 50110097  | 1-7        | 50186057  | 2-15   | 50400031  | s 2-32 |
| 186078    | 2-15       | 50110104  | 1-5        | 50186058  | 2-15   | 50400032  | s 2-32 |
| 186083    | 5-4        | 50110105  | 1-7        | 50186061  | 2-16   | 50400033  | s 2-32 |
| 186099    | 5-17       | 50110106  | 1-7        | 50186062  | 2-16   | 50400034  | s 2-32 |
| 186100    | 5-17       | 50110107  | 1-5        | 50186063  | 2-16   | 50400035  | s 2-32 |
| 186101    | 5-17       | 50110108  | 1-7        | 50186064  | 2-16   | 50400036  | s 2-32 |
| 186432    | 5-4        | 50110109  | 1-7        | 50186065  | 2-16   | 50400063  | s 2-32 |
| 186467    | 5-9        | 50110110  | 1-5        | 50186066  | 2-16   | 50400073  | s 2-32 |
| 186668    | 6-5        | 50110111  | 1-7        | 50186071  | 2-16   | 50400074  | s 2-32 |
| 186684    | 5-19       | 50110112  | 1-7        | 50186072  | 2-16   | 50400075  | s 2-32 |
| 186685    | 5-19       | 50110113  | 1-6        | 50186073  | 2-16   | 50400077  | s 2-32 |
| 186765    | 5-9        | 50110114  | 1-7        | 50186074  | 2-16   | 50400078  | s 2-32 |
| 192425    | 1-34       | 50110115  | 1-7        | 50186147  | 3-17   | 50400079  | s 2-32 |
| 192429    | 1-34       | 50110117  | 1-21       | 50186148  | 3-17   | 50400080  | s 2-32 |
| 192430    | 1-34       | 50110123  | 1-21       | 50186149  | 3-17   | 50400083  | s 2-32 |
| 192431    | 1-34       | 50110124  | 1-21       | 50186150  | 3-17   | 50400215  | o 6-10 |
| 192457    | 1-34       | 50110130  | 1-5        | 50186151  | 3-17   | 50445100  | o 1-29 |
| 192535    | 1-34       | 50110153  | 1-5        | 50186152  | 3-17   | 50450023  | 6-1    |
| 815807    | 2-33       | 50110154  | 1-5        | 50186153  | 3-17   | 50450024  | 6-1    |
| 820494    | o 5-14     | 50110155  | 1-13, 1-5  | 50186154  | 3-17   | 50450026  | 6-7    |
| 820495    | o 5-14     | 50110164  | 1-5        | 50186155  | 3-17   | 50450027  | 6-1    |
| 820753    | o 5-14     | 50110165  | 1-5        | 50186156  | 3-17   | 50450030  | 6-1    |
| 820754    | o 5-14     | 50110168  | 1-6        | 50186157  | 3-17   | 50450031  | 6-1    |
| 821221    | o 5-14     | 50110170  | 1-14, 1-20 | 50186158  | 3-17   | 50450032  | # 6-1  |
| 821421    | o 5-14     | 50110174  | 1-20       | 50186159  | 3-17   | 50450080  | 6-6    |
| 825190    | o 5-14     | 50110178  | 2-1        | 50186160  | 3-17   | 50450081  | 6-6    |
| 829692    | o 5-14     | 50110183  | 1-6        | 50188359  | 2-4    | 50450082  | 6-6    |

## Bestelnr. lijst

| Bestelnr. | Pagina             | Bestelnr. | Pagina | Bestelnr. | Pagina | Bestelnr. | Pagina |
|-----------|--------------------|-----------|--------|-----------|--------|-----------|--------|
| 50450083  | 6-6                | 50600119  | 4-6    | 50600389  | 4-14   | 50600694  | 4-10   |
| 50450100  | 6-2                | 50600120  | 4-6    | 50600390  | 4-14   | 50600695  | 4-10   |
| 50450101  | 6-2                | 50600121  | 4-6    | 50600391  | 4-14   | 50600696  | 4-10   |
| 50450121  | 3-5, 6-3           | 50600122  | 4-6    | 50600392  | 4-14   | 50600697  | 4-10   |
| 50450150  | 3-1, 6-9           | 50600123  | 4-6    | 50600393  | 4-13   | 50600740  | 4-1    |
| 50450151  | # 6-9              | 50600124  | 4-6    | 50600394  | 4-13   | 50600741  | 4-1    |
| 50450152  | 3-1, 6-9           | 50600125  | 4-6    | 50600395  | 4-13   | 50600742  | 4-1    |
| 50450153  | 3-1, 6-9           | 50600126  | 4-6    | 50600396  | 4-13   | 50600743  | 4-1    |
| 50450154  | s 6-9              | 50600127  | 4-6    | 50600397  | 4-15   | 50600744  | 4-1    |
| 50450155  | 3-4, 6-9           | 50600128  | o 4-6  | 50600430  | 4-15   | 50600745  | 4-1    |
| 50450170  | # 6-2              | 50600129  | 4-6    | 50600431  | 4-15   | 50600748  | o 4-1  |
| 50450171  | s 6-2              | 50600130  | 4-6    | 50600450  | 4-4    | 50600749  | 4-1    |
| 50450172  | s 6-2              | 50600131  | 4-6    | 50600451  | 4-4    | 50600750  | 4-1    |
| 50450180  | 6-7                | 50600132  | 4-2    | 50600452  | s 4-9  | 50600751  | 4-1    |
| 50450181  | 6-7                | 50600133  | 4-2    | 50600453  | s 4-9  | 50600752  | o 4-1  |
| 50450182  | 2-2, 2-8, 6-7      | 50600134  | 4-2    | 50600455  | 4-9    | 50600753  | 4-1    |
| 50450186  | 6-7                | 50600135  | 4-2    | 50600456  | 4-9    | 50621077  | 2-3    |
| 50450190  | 6-8                | 50600136  | 4-2    | 50600500  | 4-11   | 50651530  | 6-5    |
| 50450212  | 6-7                | 50600137  | 4-2    | 50600501  | 4-11   | 50651540  | 6-5    |
| 50450213  | 6-7                | 50600138  | 4-2    | 50600502  | 4-11   | 50651550  | 6-5    |
| 50450220  | 2-2, 2-8, 2-9, 6-8 | 50600139  | 4-2    | 50600503  | 4-11   | 50660300  | 2-1    |
| 50450221  | 6-8                | 50600144  | 4-2    | 50600504  | 4-11   | 50660301  | 2-1    |
| 50450223  | 6-8                | 50600145  | 4-2    | 50600505  | 4-11   | 50660302  | 2-1    |
| 50450230  | o 6-6              | 50600162  | 4-6    | 50600506  | 4-11   | 50660303  | o 2-5  |
| 50450241  | 6-5                | 50600163  | 4-6    | 50600507  | 4-11   | 50660304  | o 2-5  |
| 50450242  | o 6-5              | 50600174  | 4-5    | 50600508  | 4-11   | 50660318  | 2-8    |
| 50450250  | 6-5                | 50600175  | 4-5    | 50600509  | 4-11   | 50660319  | s 2-8  |
| 50450251  | 6-5                | 50600176  | 4-5    | 50600510  | 4-11   | 50660346  | 2-2    |
| 50450252  | 6-5                | 50600177  | 4-5    | 50600511  | 4-11   | 50660347  | 2-2    |
| 50450253  | 6-5                | 50600178  | 4-5    | 50600512  | 4-11   | 50663009  | 2-17   |
| 50450290  | 6-4                | 50600179  | 4-5    | 50600513  | 4-11   | 50663025  | # 2-26 |
| 50450291  | 6-4                | 50600180  | 4-5    | 50600514  | 4-11   | 50663026  | s 2-26 |
| 50457357  | 1-8                | 50600181  | 4-5    | 50600515  | 4-11   | 50663047  | s 2-26 |
| 50457358  | 1-8                | 50600182  | 4-5    | 50600516  | 4-11   | 50664636  | 2-25   |
| 50457359  | 1-8                | 50600183  | 4-5    | 50600517  | 4-11   | 50664637  | 2-23   |
| 50457360  | 1-8                | 50600198  | 4-6    | 50600530  | 4-11   | 50664655  | 2-24   |
| 50457362  | 1-8                | 50600199  | 4-6    | 50600531  | 4-11   | 50665050  | s 2-28 |
| 50457377  | o 1-8              | 50600249  | 4-7    | 50600532  | 4-11   | 50665101  | s 2-28 |
| 50457378  | o 1-8              | 50600250  | 4-7    | 50600533  | 4-11   | 50665102  | s 2-28 |
| 50457379  | 1-8                | 50600251  | 4-7    | 50600534  | 4-11   | 50665103  | s 2-28 |
| 50457545  | o 1-8              | 50600252  | 4-7    | 50600535  | 4-11   | 50665104  | s 2-28 |
| 50457557  | 1-8                | 50600253  | 4-7    | 50600536  | 4-11   | 50687824  | s 2-23 |
| 50457841  | 1-47               | 50600254  | 4-7    | 50600537  | 4-11   | 50687826  | 2-23   |
| 50457843  | 1-47               | 50600255  | 4-7    | 50600538  | 4-11   | 50687828  | s 2-23 |
| 50457992  | 1-7                | 50600256  | 4-7    | 50600539  | 4-11   | 50687902  | 1-7    |
| 50457994  | 1-7                | 50600257  | 4-7    | 50600540  | 4-11   | 50687903  | o 1-6  |
| 50457997  | 1-7                | 50600258  | 4-7    | 50600541  | 4-11   | 50688596  | s 2-23 |
| 50458000  | o 1-8              | 50600259  | 4-7    | 50600543  | 4-12   | 50688598  | s 2-23 |
| 50458137  | 1-8                | 50600260  | 4-7    | 50600547  | 4-12   | 50690450  | s 2-26 |
| 50458171  | 1-8                | 50600261  | 4-9    | 50600553  | 4-12   | 50750102  | 1-31   |
| 50459024  | 2-7                | 50600262  | 4-9    | 50600561  | 4-12   | 50750105  | o 1-31 |
| 50460479  | o 1-2              | 50600263  | 4-9    | 50600569  | 4-12   | 50750120  | o 1-42 |
| 50460480  | o 1-2              | 50600264  | 4-9    | 50600571  | 4-12   | 50750121  | o 1-44 |
| 50460500  | o 1-2              | 50600267  | 4-9    | 50600575  | 4-12   | 50750122  | o 1-44 |
| 50561035  | o 2-29             | 50600268  | 4-9    | 50600588  | 4-4    | 50750123  | o 1-44 |
| 50561036  | o 2-29             | 50600269  | 4-9    | 50600590  | 4-4    | 50750124  | o 1-44 |
| 50561037  | o 2-29             | 50600270  | 4-9    | 50600591  | o 4-4  | 50750125  | o 1-44 |
| 50561038  | o 2-29             | 50600271  | 4-9    | 50600640  | 4-8    | 50750126  | o 1-44 |
| 50561046  | o 2-29             | 50600272  | 4-9    | 50600641  | 4-8    | 50750127  | o 1-44 |
| 50561054  | o 2-29             | 50600273  | 4-9    | 50600642  | o 4-8  | 50750128  | o 1-42 |
| 50562677  | o 2-29             | 50600274  | 4-9    | 50600643  | 4-8    | 50750129  | o 1-42 |
| 50591365  | 2-26               | 50600318  | 4-2    | 50600644  | 4-8    | 50750130  | o 1-42 |
| 50600100  | 4-6                | 50600319  | 4-2    | 50600645  | 4-8    | 50750131  | o 1-42 |
| 50600101  | 4-6                | 50600324  | 4-2    | 50600646  | 4-8    | 50750132  | o 1-42 |
| 50600102  | 4-6                | 50600325  | 4-2    | 50600647  | 4-8    | 50750133  | o 1-42 |
| 50600103  | 4-6                | 50600326  | 4-2    | 50600648  | 4-8    | 50750134  | o 1-42 |
| 50600104  | 4-6                | 50600327  | 4-2    | 50600649  | 4-8    | 50750135  | o 1-42 |
| 50600105  | 4-6                | 50600370  | 4-3    | 50600650  | 4-8    | 50750136  | o 1-42 |
| 50600108  | 4-6                | 50600371  | 4-3    | 50600651  | 4-8    | 50750137  | o 1-42 |
| 50600109  | 4-6                | 50600372  | 4-3    | 50600652  | 4-8    | 50750138  | o 1-42 |
| 50600110  | o 4-6              | 50600373  | 4-3    | 50600653  | 4-8    | 50750139  | o 1-42 |
| 50600111  | 4-6                | 50600374  | 4-3    | 50600654  | 4-8    | 50750140  | o 1-42 |
| 50600112  | 4-6                | 50600375  | 4-3    | 50600655  | 4-8    | 50750144  | s 2-7  |
| 50600113  | 4-6                | 50600376  | 4-4    | 50600687  | 4-11   | 50750145  | s 2-7  |
| 50600114  | 4-6                | 50600378  | 4-4    | 50600688  | 4-11   | 50750146  | o 1-42 |
| 50600115  | 4-6                | 50600379  | 4-4    | 50600690  | 4-10   | 50750147  | o 1-44 |
| 50600116  | 4-6                | 50600380  | 4-4    | 50600691  | 4-10   | 50750148  | s 2-7  |
| 50600117  | 4-6                | 50600381  | 4-15   | 50600692  | 4-10   | 50750149  | s 2-7  |
| 50600118  | 4-6                | 50600382  | 4-15   | 50600693  | 4-10   | 50773906  | # 2-23 |

## Bestelnr. lijst

| Bestelnr. | Pagina | Bestelnr. | Pagina | Bestelnr. | Pagina                           | Bestelnr. | Pagina     |
|-----------|--------|-----------|--------|-----------|----------------------------------|-----------|------------|
| 50804303  | 1-26   | 50811432  | 3-9    | 50811910  | 3-5                              | 50822794  | s 2-33     |
| 50804422  | 1-46   | 50811434  | 3-9    | 50811926  | 3-12                             | 50822795  | s 2-33     |
| 50804423  | 1-46   | 50811435  | 3-8    | 50811927  | 3-12                             | 50822798  | s 2-33     |
| 50804425  | 1-46   | 50811436  | 3-9    | 50811928  | 3-12                             | 50825001  | 3-2        |
| 50805872  | 1-54   | 50811437  | 3-9    | 50811929  | 3-12                             | 50825003  | 3-2        |
| 50805873  | 1-54   | 50811438  | o 3-8  | 50811930  | 3-13                             | 50825004  | s 3-3, 6-4 |
| 50805874  | 1-54   | 50811439  | 3-9    | 50820003  | 2-26                             | 50825017  | s 3-30     |
| 50805875  | o 1-54 | 50811449  | 3-11   | 50820004  | 2-26                             | 50825018  | s 3-30     |
| 50805876  | 1-54   | 50811450  | 3-11   | 50820007  | 2-10, 2-24, 3-3, 6-1             | 50825019  | s 3-30     |
| 50805877  | 1-54   | 50811562  | 3-8    | 50820010  | 6-1                              | 50825020  | s 3-30     |
| 50805878  | 1-54   | 50811564  | 3-10   | 50820011  | s 6-1                            | 50825021  | s 3-30     |
| 50806200  | 1-26   | 50811565  | 3-10   | 50820012  | 2-10, 2-44, 3-30, 3-4, 6-7       | 50880001  | 1-61       |
| 50806250  | 2-6    | 50811566  | 3-10   | 50820014  | 2-10, 2-11, 2-24, 2-44, 2-9, 6-7 | 50880004  | 1-61       |
| 50806251  | 2-6    | 50811567  | 3-10   | 50820015  | 2-10, 2-44, 6-1                  | 50880006  | 1-61       |
| 50806252  | 2-6    | 50811684  | 3-13   | 50820017  | 2-28, 6-7                        | 50880007  | 1-61       |
| 50806253  | 2-6    | 50811708  | s 3-26 | 50820020  | 2-44, 6-1                        | 50880008  | 1-61       |
| 50806254  | ⊕ 2-6  | 50811713  | # 3-30 | 50820030  | 2-11, 6-1                        | 50880009  | 1-61       |
| 50806255  | ⊕ 2-6  | 50811714  | 3-31   | 50820040  | 3-31, 6-1                        | 50880010  | 1-61       |
| 50806256  | ⊕ 2-6  | 50811728  | ⊕ 3-30 | 50820050  | 2-11, 2-17, 3-33, 6-1            | 50880012  | 1-61       |
| 50806257  | ⊕ 2-6  | 50811729  | 2-12   | 50820060  | 6-1                              | 50880014  | 1-61       |
| 50806258  | 2-6    | 50811731  | 3-11   | 50820080  | 6-3                              | 50880016  | 1-61       |
| 50806259  | 2-6    | 50811737  | 2-18   | 50820100  | s 6-3                            | 50880018  | 1-61       |
| 50807842  | 1-46   | 50811738  | 2-18   | 50820120  | s 6-3                            | 50880026  | 1-61       |
| 50807854  | 1-30   | 50811739  | 2-18   | 50822701  | o 2-37                           | 50880027  | 1-61       |
| 50807902  | 1-30   | 50811740  | 2-18   | 50822702  | o 2-37                           | 50880029  | 1-61       |
| 50807909  | 1-30   | 50811743  | 2-19   | 50822703  | o 2-37                           | 50880031  | 1-61       |
| 50808500  | 1-55   | 50811780  | 2-14   | 50822704  | o 2-37                           | 50880032  | 1-61       |
| 50808501  | 1-55   | 50811781  | 2-14   | 50822705  | o 2-37                           | 50880033  | 1-61       |
| 50808502  | 1-55   | 50811782  | 2-14   | 50822706  | o 2-37                           | 50880036  | 1-61       |
| 50808600  | # 1-57 | 50811783  | 2-14   | 50822707  | o 2-37                           | 50880038  | 1-61       |
| 50808601  | # 1-57 | 50811784  | 2-14   | 50822708  | o 2-37                           | 50880039  | # 1-61     |
| 50811001  | 3-1    | 50811785  | 2-14   | 50822709  | o 2-37                           | 50880040  | 1-61       |
| 50811002  | 3-1    | 50811803  | 3-21   | 50822710  | o 2-37                           | 50880042  | 1-61       |
| 50811003  | 3-1    | 50811804  | 3-18   | 50822711  | s 2-37                           | 50880044  | 1-61       |
| 50811025  | 3-7    | 50811805  | 3-18   | 50822712  | o 2-37                           | 50880045  | 1-61       |
| 50811026  | 3-7    | 50811806  | 3-27   | 50822713  | o 2-37                           | 50880050  | 1-61       |
| 50811027  | 3-7    | 50811807  | 3-32   | 50822714  | s 2-37                           | 50880139  | 1-61       |
| 50811028  | 3-7    | 50811808  | 3-15   | 50822715  | s 2-37                           | 50880159  | s 1-61     |
| 50811029  | 3-6    | 50811809  | 3-15   | 50822716  | o 2-37                           | 50881001  | # 1-62     |
| 50811030  | 3-7    | 50811810  | 3-37   | 50822717  | o 2-37                           | 50882620  | 1-61       |
| 50811031  | 3-7    | 50811812  | o 3-34 | 50822718  | s 2-37                           | 50883018  | 1-61       |
| 50811032  | 3-7    | 50811813  | o 3-34 | 50822719  | s 2-37                           | 50883022  | 1-61       |
| 50811034  | 3-9    | 50811814  | o 3-26 | 50822720  | s 2-37                           | 50883220  | 1-61       |
| 50811036  | 3-9    | 50811815  | o 3-34 | 50822721  | o 2-37                           | 50883230  | s 1-61     |
| 50811037  | 3-9    | 50811816  | o 3-34 | 50822722  | o 2-37                           | 50883520  | # 1-61     |
| 50811040  | 3-9    | 50811817  | o 3-33 | 50822723  | o 2-37                           | 50883525  | s 1-61     |
| 50811041  | 3-9    | 50811818  | o 3-33 | 50822724  | o 2-37                           | 50883530  | 1-61       |
| 50811070  | 3-11   | 50811819  | o 3-33 | 50822725  | s 2-37                           | 50930124  | 2-17       |
| 50811071  | 3-11   | 50811820  | 3-35   | 50822726  | s 2-37                           | 50945505  | s 2-38     |
| 50811128  | 3-13   | 50811821  | o 3-35 | 50822733  | o 2-37                           | 58100005  | 1-20       |
| 50811130  | 3-13   | 50811822  | o 3-35 | 50822734  | o 2-37                           | 58100011  | 1-20       |
| 50811132  | 3-13   | 50811823  | o 3-35 | 50822735  | s 2-37                           | 58100012  | 1-20       |
| 50811134  | 3-13   | 50811824  | o 3-35 | 50822736  | o 2-37                           | 58100013  | 1-20       |
| 50811136  | 3-13   | 50811825  | o 3-35 | 50822737  | o 2-37                           | 58100014  | 1-20       |
| 50811234  | 5-12   | 50811826  | o 3-35 | 50822738  | o 2-37                           | 58100015  | 1-21       |
| 50811300  | s 2-12 | 50811827  | o 3-35 | 50822739  | 2-37                             | 58100016  | 1-20       |
| 50811401  | 3-7    | 50811828  | o 3-35 | 50822740  | o 2-37                           | 58100017  | 1-20       |
| 50811402  | s 3-6  | 50811829  | o 3-35 | 50822741  | s 2-37                           | 58100018  | 1-14, 1-21 |
| 50811403  | 3-7    | 50811830  | o 3-35 | 50822742  | o 2-37                           | 58100021  | 1-21       |
| 50811404  | # 3-6  | 50811831  | o 3-35 | 50822743  | o 2-37                           | 58100022  | 1-21       |
| 50811407  | 3-7    | 50811832  | o 3-36 | 50822744  | o 2-37                           | 58100023  | 1-22       |
| 50811408  | 3-7    | 50811833  | o 3-36 | 50822745  | o 2-37                           | 58100024  | 1-22       |
| 50811409  | 3-6    | 50811834  | o 3-36 | 50822751  | # 2-37                           | 58100025  | 1-21       |
| 50811410  | 3-7    | 50811835  | o 3-36 | 50822752  | s 2-37                           | 58100026  | 1-21       |
| 50811413  | 3-7    | 50811836  | o 3-36 | 50822753  | 2-37                             | 58100027  | 1-21       |
| 50811414  | 3-6    | 50811837  | o 3-36 | 50822754  | 2-37                             | 58100028  | 1-21       |
| 50811418  | 3-8    | 50811838  | o 3-36 | 50822780  | s 2-33                           | 58100029  | 1-21       |
| 50811419  | 3-9    | 50811839  | o 3-36 | 50822781  | s 2-33                           | 58100031  | 1-21       |
| 50811420  | 3-8    | 50811840  | o 3-36 | 50822782  | s 2-33                           | 58100032  | 1-21       |
| 50811421  | 3-8    | 50811900  | 3-1    | 50822783  | s 2-33                           | 58100033  | 1-21       |
| 50811422  | 3-8    | 50811901  | 3-2    | 50822784  | s 2-33                           | 58100034  | 1-21       |
| 50811423  | 3-8    | 50811902  | 3-2    | 50822785  | s 2-33                           | 58100038  | 1-21       |
| 50811424  | 3-9    | 50811903  | 3-3    | 50822786  | s 2-33                           | 58100040  | 1-21       |
| 50811425  | 3-8    | 50811904  | 3-4    | 50822787  | s 2-33                           | 58100041  | 1-21       |
| 50811426  | 3-9    | 50811905  | 3-4    | 50822790  | s 2-33                           | 58100060  | 1-22       |
| 50811427  | 3-9    | 50811906  | 3-4    | 50822791  | s 2-33                           | 58100091  | 1-21       |
| 50811428  | 3-8    | 50811907  | 3-4    | 50822792  | s 2-33                           | 58100096  | 1-20       |
| 50811429  | 3-9    | 50811908  | 3-5    | 50822793  | s 2-33                           | 58100099  | 1-21       |
| 50811430  | 3-8    | 50811909  | 3-5    |           |                                  | 58100101  | 1-21       |

## Bestelnr. lijst

| Bestelnr. | Pagina     | Bestelnr. | Pagina     | Bestelnr. | Pagina     | Bestelnr. | Pagina |
|-----------|------------|-----------|------------|-----------|------------|-----------|--------|
| 58100183  | 1-18       | 58110401  | 1-1        | 58120042  | 1-16       | 58186800  | 3-14   |
| 58100191  | 1-20       | 58110402  | 1-1        | 58120043  | 1-16       | 58186801  | 3-14   |
| 58100218  | 1-15       | 58110403  | 1-1        | 58120044  | 1-16       | 58186802  | 3-14   |
| 58100231  | 1-15       | 58110404  | 1-1        | 58120045  | 1-16       | 58186803  | 3-14   |
| 58100233  | 1-15       | 58110405  | 1-1        | 58120046  | 1-16       | 58186804  | 3-14   |
| 58100234  | 1-15       | 58110406  | 1-1        | 58120060  | 1-14, 1-20 | 58186805  | 3-14   |
| 58100237  | 1-15       | 58110407  | 1-1        | 58120061  | 1-20       | 58186806  | 3-14   |
| 58100250  | 1-21       | 58110408  | 1-1        | 58120062  | 1-20       | 58186807  | 3-14   |
| 58100251  | 1-21       | 58110409  | 1-1        | 58120063  | 1-20       | 58186808  | 3-14   |
| 58100252  | 1-21       | 58110410  | 1-1        | 58120065  | 1-21       | 58186809  | 3-14   |
| 58100253  | 1-21       | 58110411  | 1-1        | 58120066  | 1-21       | 58186810  | 3-14   |
| 58100254  | 1-21       | 58110412  | 1-1        | 58120067  | 1-21       | 58186811  | 3-14   |
| 58100255  | 1-20       | 58110413  | 1-1        | 58120068  | 1-21       | 58186879  | 3-37   |
| 58100300  | 1-24       | 58110415  | o 1-2      | 58120070  | 1-22       | 58186880  | 3-30   |
| 58100385  | 1-24       | 58110416  | 1-1        | 58120220  | 1-16       | 58192273  | 1-51   |
| 58100386  | 1-24       | 58110417  | 1-1        | 58120227  | 1-16       | 58192274  | 1-51   |
| 58100387  | 1-24, 1-26 | 58110418  | o 1-1      | 58120228  | 1-16       | 58192275  | 1-51   |
| 58100388  | 1-24       | 58110419  | o 1-1      | 58165001  | 1-52       | 58192276  | 1-51   |
| 58100389  | 1-24       | 58110420  | o 1-1      | 58165002  | 1-52       | 58192277  | 1-51   |
| 58100399  | 1-24       | 58110421  | o 1-1      | 58165003  | 1-52       | 58192278  | 1-51   |
| 58100700  | 1-22       | 58110423  | o 1-1      | 58165004  | o 1-52     | 58192279  | 1-51   |
| 58100701  | 1-22       | 58112011  | 1-16       | 58165005  | 1-52       | 58192392  | 1-51   |
| 58100702  | 1-22       | 58112015  | 1-16       | 58165006  | 1-52       | 58192567  | 1-51   |
| 58100703  | 1-22       | 58114105  | 1-5        | 58165010  | 1-52       | 58192568  | 1-51   |
| 58100704  | 1-22       | 58114108  | 1-21       | 58185518  | 3-21       | 58192659  | 1-50   |
| 58101004  | 1-19       | 58114125  | 1-5        | 58185614  | 3-25       | 58192660  | 1-50   |
| 58101005  | 1-19       | 58114132  | 1-5        | 58185703  | 3-38       | 58192661  | 1-50   |
| 58101006  | 1-19       | 58114170  | o 1-17     | 58185799  | 3-21       | 58192662  | 1-50   |
| 58101018  | 1-19       | 58115002  | 1-12       | 58186112  | 3-20       | 58192663  | 1-50   |
| 58101019  | 1-19       | 58115004  | 1-12, 1-13 | 58186113  | 3-20       | 58192964  | 1-35   |
| 58101020  | 1-19       | 58115007  | 1-12       | 58186114  | 3-20       | 58192965  | 1-51   |
| 58102001  | 1-19       | 58115008  | 1-12       | 58186118  | 3-19       | 58400131  | s 2-31 |
| 58102002  | 1-19       | 58115009  | 1-12       | 58186119  | 3-19       | 58400132  | s 2-31 |
| 58102003  | 1-19       | 58115010  | 1-12, 1-13 | 58186120  | 3-19       | 58400133  | 2-31   |
| 58102007  | 1-19       | 58115011  | 1-12       | 58186121  | 3-19       | 58400134  | s 2-31 |
| 58104015  | 1-17       | 58115012  | 1-12       | 58186122  | 3-19       | 58400135  | 2-31   |
| 58104021  | 1-17       | 58115014  | 1-12       | 58186124  | 3-19       | 58400136  | 2-31   |
| 58104041  | 1-17       | 58115018  | 1-14, 1-49 | 58186125  | 3-19       | 58400137  | 2-31   |
| 58104048  | 1-17       | 58115021  | 1-12       | 58186140  | 3-22       | 58400138  | 2-31   |
| 58104049  | 1-17       | 58115024  | 1-12, 1-14 | 58186142  | 3-22       | 58400139  | 2-31   |
| 58104050  | 1-17       | 58115026  | 1-12       | 58186144  | 3-22       | 58400140  | 2-31   |
| 58104051  | 1-17       | 58115027  | o 1-12     | 58186145  | 3-22       | 58400141  | s 2-31 |
| 58104052  | 1-17       | 58115033  | o 1-12     | 58186146  | 3-22       | 58400142  | 2-31   |
| 58104053  | 1-17       | 58115034  | 1-12       | 58186306  | 2-16       | 58400143  | 2-31   |
| 58104054  | 1-17       | 58115039  | 1-12       | 58186307  | 2-16       | 58400144  | 2-31   |
| 58104055  | 1-17       | 58115042  | 1-12       | 58186371  | 2-13       | 58400145  | 2-32   |
| 58104063  | 1-24       | 58115044  | o 1-12     | 58186372  | 2-13       | 58400147  | 2-31   |
| 58110118  | 1-21       | 58116000  | 1-55       | 58186373  | 2-13       | 58400149  | 2-31   |
| 58110121  | 1-14, 1-21 | 58116001  | 1-55       | 58186374  | 2-13       | 58400150  | 2-31   |
| 58110136  | 1-21       | 58116002  | 1-55       | 58186377  | 2-13       | 58400151  | s 2-31 |
| 58110139  | 1-15       | 58116003  | 1-55       | 58186378  | 2-13       | 58400152  | 2-31   |
| 58110142  | 1-24       | 58116400  | 1-4        | 58186381  | 2-13       | 58400153  | 2-31   |
| 58110143  | 1-15       | 58116401  | 1-4        | 58186382  | 2-13       | 58400154  | 2-32   |
| 58110144  | 1-15       | 58116402  | o 1-4      | 58186385  | 2-13       | 58400155  | s 2-32 |
| 58110145  | 1-15       | 58116502  | 1-11       | 58186386  | 2-13       | 58400156  | 2-32   |
| 58110161  | 1-24       | 58116504  | 1-11       | 58186387  | 2-13       | 58400157  | 2-32   |
| 58110171  | 1-29       | 58116507  | 1-11       | 58186388  | 2-13       | 58400158  | 2-31   |
| 58110175  | 1-21       | 58116508  | 1-11       | 58186399  | 2-13       | 58400159  | 2-31   |
| 58110176  | 1-20       | 58116509  | 1-11       | 58186400  | 2-13       | 58400160  | 2-31   |
| 58110180  | 1-14, 1-15 | 58116510  | 1-11       | 58186401  | 2-13       | 58400161  | 2-31   |
| 58110181  | 1-14, 1-15 | 58116511  | 1-11       | 58186408  | 2-13       | 58400162  | s 2-31 |
| 58110182  | 1-21       | 58116512  | 1-11       | 58186409  | 2-13       | 58400163  | 2-31   |
| 58110185  | 1-20       | 58116514  | 1-11       | 58186414  | 2-13       | 58400164  | s 2-32 |
| 58110186  | 1-29       | 58116515  | 1-11       | 58186415  | 2-13       | 58400165  | s 2-31 |
| 58110187  | 1-29       | 58116517  | 1-52       | 58186571  | 3-21       | 58400166  | 2-31   |
| 58110188  | 1-29       | 58116520  | 1-11       | 58186572  | 3-21       | 58400167  | 2-32   |
| 58110190  | 1-29       | 58116521  | 1-11       | 58186573  | 3-21       | 58400168  | 2-32   |
| 58110192  | 1-15       | 58118119  | 1-15       | 58186574  | 3-21       | 58400170  | 2-31   |
| 58110194  | 1-15       | 58120002  | 1-20       | 58186789  | 3-14       | 58400171  | s 2-31 |
| 58110204  | 1-29       | 58120005  | 1-20       | 58186790  | 3-14       | 58400174  | 2-32   |
| 58110206  | 1-29       | 58120008  | 1-20       | 58186791  | 3-14       | 58400175  | 2-32   |
| 58110229  | o 1-24     | 58120013  | 1-20       | 58186792  | 3-14       | 58400179  | 2-32   |
| 58110270  | 1-15       | 58120014  | 1-20       | 58186793  | 3-14       | 58400183  | s 2-32 |
| 58110272  | 1-15       | 58120015  | 1-20       | 58186794  | 3-14       | 58400184  | 2-31   |
| 58110273  | 1-15       | 58120017  | 1-20       | 58186795  | 3-14       | 58400185  | s 2-32 |
| 58110274  | o 1-15     | 58120018  | 1-20       | 58186796  | 3-14       | 58400187  | s 2-31 |
| 58110281  | 1-15       | 58120019  | 1-20       | 58186797  | 3-14       | 58400188  | s 2-31 |
| 58110356  | 1-6        | 58120020  | 1-20       | 58186798  | 3-14       | 58400190  | s 2-31 |
| 58110400  | 1-1        | 58120041  | 1-16       | 58186799  | 3-14       | 58400192  | s 2-31 |



## Bestelnr. lijst

| Bestelnummer | Pagina | Bestelnummer | Pagina | Bestelnummer | Pagina     | Bestelnummer | Pagina |
|--------------|--------|--------------|--------|--------------|------------|--------------|--------|
| 58400193     | 2-31   | 58562752     | s 2-30 | 58807817     | 1-41       | 58808808     | 1-58   |
| 58400194     | 2-32   | 58562753     | s 2-30 | 58807830     | 1-25, 1-26 | 58808809     | 1-58   |
| 58400195     | s 2-32 | 58562754     | s 2-30 | 58807831     | 1-25       | 58808810     | 1-58   |
| 58400196     | 2-31   | 58562755     | s 2-30 | 58807858     | 1-43       | 58808811     | 1-58   |
| 58400198     | 2-31   | 58562756     | s 2-30 | 58807862     | 1-43       | 58808812     | 1-58   |
| 58400201     | s 2-31 | 58562757     | s 2-30 | 58807888     | 1-41       | 58808813     | 1-58   |
| 58400202     | 2-31   | 58562920     | o 2-35 | 58807910     | o 1-30     | 58808814     | 1-58   |
| 58400205     | 2-31   | 58562921     | o 2-35 | 58807950     | 1-27       | 58808815     | 1-58   |
| 58400206     | 2-31   | 58562922     | o 2-35 | 58807951     | 1-27       | 58808816     | 1-58   |
| 58400210     | o 6-10 | 58562923     | o 2-35 | 58807952     | 1-27       | 58808817     | 1-58   |
| 58400212     | 6-10   | 58562924     | o 2-35 | 58807953     | 1-27       | 58808818     | 1-58   |
| 58400214     | 6-10   | 58562925     | o 2-35 | 58807955     | 1-41       | 58808819     | 1-59   |
| 58457361     | 1-8    | 58562926     | o 2-35 | 58807956     | 1-41       | 58808820     | 1-59   |
| 58458779     | 1-24   | 58562927     | o 2-35 | 58807970     | 1-45       | 58808821     | ⊕ 1-59 |
| 58458780     | 1-24   | 58562928     | o 2-35 | 58808102     | 1-48       | 58808822     | ⊕ 1-59 |
| 58458781     | 1-24   | 58562929     | o 2-35 | 58808104     | 1-48       | 58808823     | 1-59   |
| 58458784     | 1-3    | 58562930     | o 2-35 | 58808107     | 1-48       | 58808824     | 1-59   |
| 58458785     | 1-3    | 58562931     | o 2-35 | 58808111     | 1-48       | 58808829     | 1-60   |
| 58458786     | 1-3    | 58562932     | o 2-35 | 58808113     | 1-48       | 58808830     | 1-60   |
| 58458788     | 1-25   | 58562933     | o 2-35 | 58808115     | 1-48       | 58808831     | 1-60   |
| 58458789     | 1-41   | 58562934     | o 2-35 | 58808117     | 1-48       | 58808832     | 1-60   |
| 58458790     | o 1-9  | 58562935     | o 2-35 | 58808118     | 1-48       | 58808833     | 1-60   |
| 58458791     | o 1-9  | 58562936     | o 2-35 | 58808125     | o 1-48     | 58808834     | 1-60   |
| 58458792     | o 1-9  | 58562937     | o 2-35 | 58808200     | 1-49       | 58808835     | 1-58   |
| 58458793     | o 1-9  | 58562938     | o 2-35 | 58808201     | 1-49       | 58808836     | 1-58   |
| 58458794     | o 1-9  | 58562939     | o 2-35 | 58808202     | o 1-49     | 58808837     | 1-59   |
| 58458795     | o 1-9  | 58562940     | o 2-35 | 58808203     | 1-14, 1-49 | 58808838     | 1-59   |
| 58458797     | o 1-9  | 58562941     | o 2-35 | 58808204     | o 1-49     | 58808839     | 1-59   |
| 58458798     | o 1-9  | 58562942     | o 2-35 | 58808205     | o 1-49     | 58808840     | 1-59   |
| 58458799     | o 1-9  | 58562943     | o 2-35 | 58808206     | 1-49       | 58808841     | 1-60   |
| 58458800     | o 1-9  | 58562944     | o 2-35 | 58808209     | 1-49       | 58808842     | 1-60   |
| 58458801     | o 1-9  | 58562945     | o 2-35 | 58808213     | 1-49       | 58808843     | 1-58   |
| 58458802     | o 1-9  | 58562946     | o 2-35 | 58808214     | 1-49       | 58811842     | 3-18   |
| 58459365     | 1-35   | 58562947     | o 2-35 | 58808215     | 1-49       | 58811950     | 3-16   |
| 58459419     | 1-35   | 58562948     | o 2-35 | 58808216     | 1-49       | 62556011     | o 2-20 |
| 58459436     | 1-35   | 58562949     | o 2-35 | 58808217     | 1-49       | 62556012     | o 2-20 |
| 58459439     | 1-34   | 58562990     | s 2-30 | 58808218     | o 1-49     | 62556013     | o 2-20 |
| 58459446     | 1-34   | 58665105     | 3-28   | 58808222     | 1-49       | 62556014     | o 2-20 |
| 58459455     | 1-34   | 58665106     | s 3-28 | 58808225     | 1-49       | 62556021     | o 2-20 |
| 58459461     | 1-36   | 58665107     | 3-29   | 58808226     | 1-49       | 62556022     | o 2-20 |
| 58459767     | 1-10   | 58665108     | 3-29   | 58808227     | o 1-49     | 62556023     | o 2-20 |
| 58459768     | s 1-10 | 58750101     | s 1-28 | 58808232     | 1-49       | 62556024     | o 2-20 |
| 58459769     | 1-10   | 58802435     | 1-29   | 58808234     | 1-49       | 62556031     | o 2-20 |
| 58459770     | s 1-10 | 58803072     | 1-43   | 58808235     | 1-49       | 62556032     | o 2-20 |
| 58459771     | 1-10   | 58803073     | 1-43   | 58808236     | 1-49       | 68002122     | o 2-44 |
| 58532354     | s 2-41 | 58803074     | 1-43   | 58808239     | 1-49       | 68010013     | o 2-11 |
| 58532358     | s 2-41 | 58803104     | 1-43   | 58808241     | 1-49       | 68010014     | o 2-11 |
| 58532361     | s 2-41 | 58803823     | 1-25   | 58808243     | 1-49       | 68010015     | o 2-11 |
| 58532382     | s 2-41 | 58804279     | 1-31   | 58808244     | o 1-49     | 68010023     | o 2-11 |
| 58532384     | s 2-41 | 58804280     | 1-32   | 58808245     | 1-49       | 68010024     | o 2-11 |
| 58532387     | s 2-41 | 58804281     | 1-32   | 58808246     | o 1-49     | 68010025     | o 2-11 |
| 58532390     | s 2-41 | 58804282     | 1-33   | 58808610     | 1-57       | 68010043     | o 2-11 |
| 58532391     | s 2-41 | 58804301     | 1-32   | 58808611     | 1-57       | 68010044     | o 2-11 |
| 58562686     | s 2-30 | 58804304     | 1-26   | 58808612     | 1-57       | 68010045     | o 2-11 |
| 58562687     | s 2-30 | 58804351     | 1-32   | 58808613     | 1-57       | 68255130     | o 2-20 |
| 58562688     | s 2-30 | 58804352     | 1-31   | 58808614     | 1-57       | 68255140     | o 2-20 |
| 58562689     | s 2-30 | 58804353     | 1-32   | 58808620     | 1-56       | 68255150     | o 2-20 |
| 58562691     | s 2-30 | 58805859     | 1-53   | 58808621     | 1-56       | 68255230     | o 2-20 |
| 58562692     | s 2-30 | 58805861     | 1-53   | 58808622     | 1-56       | 68255240     | o 2-20 |
| 58562693     | s 2-30 | 58805862     | 1-53   | 58808623     | 1-56       | 68255250     | o 2-20 |
| 58562694     | s 2-30 | 58805863     | 1-53   | 58808701     | 1-23       | 68302301     | s 2-44 |
| 58562695     | s 2-30 | 58805864     | 1-53   | 58808702     | 1-23       | 68302302     | s 2-44 |
| 58562696     | s 2-30 | 58805865     | 1-53   | 58808703     | ⊕ 1-23     | 68302303     | s 2-44 |
| 58562697     | s 2-30 | 58805866     | 1-53   | 58808704     | ⊕ 1-23     | 68302304     | s 2-44 |
| 58562698     | s 2-30 | 58805867     | 1-53   | 58808705     | 1-23       | 68302305     | s 2-44 |
| 58562700     | s 2-30 | 58805868     | 1-53   | 58808706     | 1-23       | 68302306     | s 2-44 |
| 58562701     | s 2-30 | 58805870     | 1-54   | 58808707     | 1-23       | 68302307     | s 2-44 |
| 58562702     | s 2-30 | 58805871     | 1-54   | 58808708     | 1-23       | 68302308     | s 2-44 |
| 58562703     | s 2-30 | 58805879     | 1-3    | 58808709     | 1-23       | 68302401     | s 2-44 |
| 58562738     | s 2-30 | 58806053     | 1-41   | 58808710     | 1-23       | 68302402     | s 2-44 |
| 58562739     | s 2-30 | 58806065     | 1-41   | 58808711     | 1-23       | 68302403     | s 2-44 |
| 58562740     | s 2-30 | 58806069     | 1-41   | 58808712     | ⊕ 1-23     | 68302404     | s 2-44 |
| 58562741     | s 2-30 | 58806071     | 1-41   | 58808713     | 1-23       | 68302405     | s 2-44 |
| 58562742     | s 2-30 | 58806130     | 1-43   | 58808800     | 1-58       | 68302406     | s 2-44 |
| 58562743     | s 2-30 | 58806134     | 1-43   | 58808801     | 1-58       | 68302407     | s 2-44 |
| 58562744     | s 2-30 | 58806210     | 1-26   | 58808802     | 1-58       | 68302408     | s 2-44 |
| 58562745     | s 2-30 | 58806479     | 1-41   | 58808804     | 1-58       | 68302501     | s 2-44 |
| 58562750     | s 2-30 | 58807803     | 1-41   | 58808805     | 1-58       | 68302502     | s 2-44 |
| 58562751     | s 2-30 | 58807809     | 1-41   | 58808806     | 1-58       | 68302503     | s 2-44 |

# Bestelnr. lijst

| Bestelnummer |   | Pagina |
|--------------|---|--------|
| 68302504     | s | 2-44   |
| 68302505     | s | 2-44   |
| 68302506     | s | 2-44   |
| 68302507     | s | 2-44   |
| 68302508     | s | 2-44   |
| 68303301     | s | 2-43   |
| 68303302     | s | 2-43   |
| 68303303     | s | 2-43   |
| 68303304     | s | 2-43   |
| 68303305     | s | 2-43   |
| 68303306     | s | 2-43   |
| 68303307     | s | 2-43   |
| 68303308     | s | 2-43   |
| 68303401     | s | 2-43   |
| 68303402     | s | 2-43   |
| 68303403     | s | 2-43   |
| 68303404     | s | 2-43   |
| 68303405     | s | 2-43   |
| 68303406     | s | 2-43   |
| 68303407     | s | 2-43   |
| 68303408     | s | 2-43   |
| 68303501     | s | 2-43   |
| 68303502     | s | 2-43   |
| 68303503     | s | 2-43   |
| 68303504     | s | 2-43   |
| 68303505     | s | 2-43   |
| 68303506     | s | 2-43   |
| 68303507     | s | 2-43   |
| 68303508     | s | 2-43   |
| 68370033     | o | 2-9    |
| 68370034     | o | 2-9    |
| 68370053     | o | 2-9    |
| 68370054     | o | 2-9    |
| 68370055     | o | 2-9    |
| 68370083     | o | 2-9    |
| 68370084     | o | 2-9    |
| 68370103     | o | 2-9    |
| 68370104     | o | 2-9    |
| 68370105     | o | 2-9    |
| 68380023     | o | 2-10   |
| 68380024     | o | 2-10   |
| 68380033     | o | 2-10   |
| 68380034     | o | 2-10   |
| 68380035     | o | 2-10   |
| 68380043     | o | 2-10   |
| 68380044     | o | 2-10   |
| 68380045     | o | 2-10   |
| 68380083     | o | 2-10   |
| 68380084     | o | 2-10   |
| 68380085     | o | 2-10   |
| 68390023     | o | 2-10   |
| 68390024     | o | 2-10   |
| 68390033     | o | 2-10   |
| 68390034     | o | 2-10   |
| 68390035     | o | 2-10   |
| 68390073     | o | 2-10   |
| 68390074     | o | 2-10   |
| 68390075     | o | 2-10   |
| 68400033     | o | 2-10   |
| 68400034     | o | 2-10   |
| 68400035     | o | 2-10   |
| 68400063     | o | 2-10   |
| 68400064     | o | 2-10   |
| 69470022     | o | 2-2    |
| 69563160     | o | 2-22   |
| 69563161     | o | 2-22   |
| 69563162     | o | 2-22   |
| 69563163     | o | 2-22   |
| 80384841     | s | 1-34   |



Nadruk, vermenigvuldiging en vertaling, ook gedeeltelijk, zijn alleen toegestaan na onze voorafgaande toestemming en met bronvermelding. Wijzigingen vanwege technische ontwikkelingen voorbehouden.

Wij zijn niet aansprakelijk voor drukfouten. Deze catalogus vervangt alle voorgaande uitgaven.















© Uitgave: 2020

Adres Stehle: Stehle BV, Prof. Asserweg 14 a, 5144 NC WAALWIJK, Nederland

T: +31 (0)416-541080, F: +31 (0)416-541090

verkoop@stehle.nl , www.stehle.nl

### Machines

|  |  |   |  |
|--|--|---|--|
|  Handcirkelzagen              |  Vertieale platenopdeelzaag |  4-zijdige schaafmachine |  Formaatbewerkinge machines |
|  Kap-en radiaalcirkelzagen    |  Meerbladzaag               |  CNC-frees               |  Niet gelassificeerd        |
|  Tafelcirkelzaag              |  Handbovenfrees             |  Stationaire freesbank   |  Accuhandcirkelzagen        |
|  Horizontale platenopdeelzaag |  Meerassige boormachine     |  Kantenbank              |  |

















### Toepassing

|   |   |   |
|---|---|---|
|  Abrasief  |  Abrasief - uitstekend geschikt  |  Abrasief - goed geschikt  |
|  Bouw      |  Bouw - uitstekend geschikt      |  Bouw - goed geschikt      |
|  Hout      |  Hout - uitstekend geschikt      |  Hout - goed geschikt      |
|  Plaat     |  Plaat - uitstekend geschikt     |  Plaat - goed geschikt     |
|  Aluminium |  Aluminium - uitstekend geschikt |  Aluminium - goed geschikt |
|  Staal     |  Staal - uitstekend geschikt     |  Staal - goed geschikt     |
|  Kunststof |  Kunststof - uitstekend geschikt |  Kunststof - goed geschikt |



### Uitvoering/kenmerken

|  |                                   |   |   |
|--|-----------------------------------|---|---|
|  Body aluminium                   | <b>HS</b> Hooggelegeerd snelstaal | <b>HSK</b> HSK-opspanningen   | <b>R/L</b> Rechts-/linksdraaiend  |
|  Body volhardmetaal               | <b>DP</b> Polykristaline diamant  |  Aantal geslepen kanten  |  Hardhout  |
|  Naslijpzone in mm                | <b>DM</b> Monokristaline diamant  |  Aanbevolen aanvoer      |  Zachthout |
|  Geschikt voor dwarsnede          | <b>VHW</b> Volhardmetaal          |  Stamblad gecoat         | <b>LOW NOISE</b> Stil   |
|  Geschikt voor afkorten profielen | <b>SK</b> SK-opspanningen         |  Maximaal toerental      | <b>MAN</b> Handmatige aanzet  |
|  Hardmetaal kwaliteit             | <b>BT</b> BT-opspanningen         |  Geschikt voor microchip | <b>MEC</b> Mechanische aanzet   |

### Tandvormen

|  |                |   |                  |  |                   |
|--|----------------|---|------------------|--|-------------------|
|  Vlaktand                       | <b>F</b>       |  Wisseltand                              | <b>WS</b>        |  Daktand-vlaktand                   | <b>DA-F</b>       |
|  Hollerugtand                   | <b>HR</b>      |  Wisseltand met fase                     | <b>WS-FA</b>     |  Daktand-vlaktand Duplovit          | <b>DA-F DU</b>    |
|  Vlaktand met tweezijdige fase  | <b>F-WFA</b>   |  Trapezium-vlaktand                      | <b>TR-F</b>      |  Daktand-vlaktand met fase Duplovit | <b>DA-F-FA DU</b> |
|  Vlaktand/wisseltand-wisseltand | <b>F-WS-WS</b> |  Trapezium-vlaktand met tweezijdige fase | <b>TR-F-FA</b>   |  Conische vlaktand                  | <b>KO-F</b>       |
|  Wisseltand met ashoek          | <b>WSA</b>     |  Trapezium-vlaktand-vlaktand Duplovit    | <b>TR-F-F DU</b> |  G7 Groepsvertanding                | <b>G7</b>         |
|  Prisma tand                    | <b>V</b>       |  Vlaktand met fase                       | <b>F-FA</b>      |  Enkelzijdig spitstand              | <b>ES</b>         |

### Overigen

|  |
|--|
|  Geschikt           |
|  Bijzonder geschikt |
| <b>RS</b> Ritszaag   |

### Voorraadcode

|  |  |
|--|--|
| <b>⊗</b> Modificatie resp. montage van voorraad onderdelen | <b>S</b> Productie op basis van tekening     |
| <b>o</b> Snel af magazijn leverbaar                        | <b>#</b> Uitloopt, zolang de voorraad strekt |

Alle bestelnummers zonder identificatie zijn uit voorraad leverbaar



## Innovatieve productpresentatie

NEEM VOOR UW POS-  
ONTWIKKELING CONTACT OP MET  
HET TEAM VAN STEHLE!

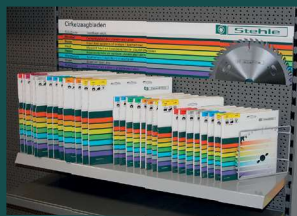

Voorbeeld: Actuele presentatie-  
mogelijkheden op het gebied van  
zagen.



STEHLE OP YOUTUBE  
SCAN DE QR-CODE!



Andere catalogi  
via uw vakhandelaar  
of op internet  
beschikbaar  
[www.stehle.nl](http://www.stehle.nl)

Uw vakhandel:



Andere catalogi van Stehle:



Groef- & Veerset  
in keermessen systeem



Standaard  
bovenfreen



Universeel frezen  
Eurosystem



Decoupeer- Recipro  
zaagbladen



Andere catalogi  
via uw vakhandelaar  
of op internet  
beschikbaar  
[www.stehle.nl](http://www.stehle.nl)

